

Water Intrusion in Base/Subgrade Materials at Bridge Ends: Final Report

Priyantha Jayawickrama, Phil Nash, Michael Leaverton
and Debakanta Mishra

Department of Civil Engineering
Texas Tech University

Center for Multidisciplinary Research
In Transportation

Submitted to:

Texas Department of Transportation

Report No. 0-5096-1

October 2005

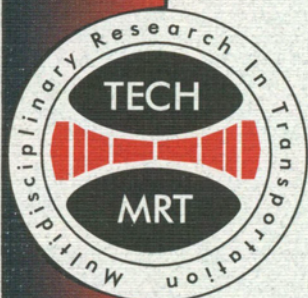

NOTICE

The United States Government and the State of Texas do not endorse products or manufacturers. Trade or manufacturers' names appear herein solely because they are considered essential to the object of this report

TECHNICAL REPORT DOCUMENTATION PAGE

1. Report No. FHWA/TX-06/0-5096-1	2. Government Accession No.	3. Recipient's Catalog No.	
4. Title and Subtitle Water Intrusion in Base/Subgrade Materials at Bridge Ends		5. Report Date October 2005	
		6. Performing Organization Code	
7. Author(s) Priyantha Jayawickrama, Phil Nash, Michael Leaverton and Deb Mishra		8. Performing Organization Report 0-5096-1	
9. Performing Organization Name and Address Texas Tech University Department of Civil Engineering Box 41023 Lubbock, Texas 79409-1023		10. Work Unit No. (TRAIS)	
		11. Contract or Grant No. 0- 5096	
12. Sponsoring Agency Name and Address Texas Department of Transportation Research and Technology Implementation Office P.O. Box 5080 Austin, TX 78763-5080		13. Type of Report and Period Cover Technical Report, 9/1/04 – 8/31/05	
		14. Sponsoring Agency Code	
15. Supplementary Notes: Project performed in cooperation with the Texas Department of Transportation and the Federal Highway Administration.			
16. Abstract: Departments of transportation spend considerable time and money repairing pavement failures that occur in the base or subgrade materials near bridge ends. Investigation of these failures often reveal saturated base/subgrade materials. The objectives of this research were to determine all possible sources for water intrusion, develop methods to recognize in-the-field causes of water collection at bridge approaches, and to develop new repair methods that can be economically implemented in the field to minimize water intrusion or remove water from soils. Research focused on existing bridge approaches, concentrated on maintenance techniques to prevent water intrusion at bridge ends, and included an extensive literature review. Several state transportation agencies were contacted for information on design features such as drainage systems and repair techniques. Researchers surveyed the 25 Texas Department of Transportation (TxDOT) districts to gather observations about major factors contributing to water intrusion and settlement at bridge ends. Four TxDOT districts were visited for field investigations of specific bridges, and one bridge was selected for field testing to determine sources of water intrusion for a recurring seepage problem. Based upon information collected, researchers developed a site assessment technique to evaluate the potential of a particular site to incur water intrusion, and methods to develop optimum repair strategies. Several recommendations resulted including an implementation project plan to examine repair techniques in field trials for comparison.			
17. Key Words Water Intrusion, Approach Slab Settlement, Joint Seal Maintenance, Pavement Maintenance, Riprap Maintenance, Bridge Maintenance, URETEK®, Slab Jacking, Mud Jacking		18. Distribution Statement No restrictions. This document is available to the public through the National Technical Information Service, Springfield, VA 22161, www.ntis.gov .	
19. Security Classif. (of this report) Unclassified	20. Security Classif. (of this page) Unclassified	21. No. of Pages 173	22. Price

Water Intrusion in Base/Subgrade Materials at Bridge Ends

by

Priyantha Jayawickrama

Phillip T. Nash

Michael Leaverton

and

Debakanta Mishra

Research Report Number 0-5096-1

Project Number 0-5096

Project Title: Water Intrusion in Base/Subgrade Materials at Bridge Ends

conducted for the

Texas Department of Transportation

and the

Federal Highway Administration

by the

CENTER FOR MULTIDISCIPLINARY RESEARCH IN TRANSPORTATION

TEXAS TECH UNIVERSITY

October 2005

AUTHOR'S DISCLAIMER

The contents of this report reflect the views of the authors who are responsible for the facts and the accuracy of the data presented herein. The contents do not necessarily reflect the official view of policies of the Texas Department of Transportation or the Federal Highway Administration. This report does not constitute a standard, specification, or regulation.

PATENT DISCLAIMER

There was no invention or discovery conceived or first actually reduced to practice in the course of or under this contract, including any art, method, process, machine, manufacture, design or composition of matter, or any new useful improvement thereof, or any variety of plant which is or may be patentable under the patent laws of the United States of America or any foreign country.

ENGINEERING DISCLAIMER

Not intended for construction, bidding, or permit purposes.

TRADE NAMES AND MANUFACTURERS' NAMES

The United States Government and the State of Texas do not endorse products or manufacturers. Trade or manufacturers' names appear herein solely because they are considered essential to the object of this report.

ACKNOWLEDGEMENTS

The authors would like to acknowledge the excellent guidance provided by the Project Director, Paul Hoelscher, Program Coordinator, Randy Hopmann, and Project Advisors Paul Montgomery, Mark McClelland, and Chad Carter in the conduct of this research and development of this final report. Thanks are extended to the Directors of Maintenance within the TxDOT districts for their assistance in completing the survey of TxDOT bridges, and especially to TxDOT personnel Ray Buzalsky, Darwin Lankford, Mike McAnally, Paul Montgomery, John Rantz, Mike Schneider and Stacey Young for their contributions to documenting repair techniques and specifications. David Sadler, Florida DOT, also provided valuable information on bridge drainage designs. The authors offer appreciation to Mike Alford, Paul Montgomery and Alan Hufstutler for conducting field site visits. Other TxDOT personnel who contributed to the success of this project are Kevin Hagan, Jerry Connors and Craig Mason. Finally, we appreciate the efforts of Dwayne Justice and members of the Taylor County Maintenance Section Crew who managed traffic control on US Highway 83 during drilling operations which allowed us to work safely on the bridge.

Implementation Statement

Based upon the findings from the research study, the following items are recommended:

- Adequate surface drainage should be provided to move water from the bridge deck through adequate channels to prevent water from intruding into the embankment fill material.
- Joints in the bridge deck or pavement surface must be properly sealed. It is imperative that the joints be periodically maintained to remove debris and ensure proper sealing.
- Subsurface drainage should be installed to remove water that has entered into the fill material. Periodic inspection is required to maintain the subsurface drainage systems and remove any obstructions that might impede the free flow of water through the drainage system.
- Geotextile fabric should be placed beneath joints and other locations beneath pavement surfaces or riprap to prevent the loss of material by erosion.
- A detailed design of a repair and installation of a under drain should be accomplished for the US 83 overpass of Antilley Road in Abilene. The under drain design should be similar to the detail provided by the Tyler district.

An implementation project should be initiated to demonstrate the effectiveness of the repair and maintenance procedures recommended from the study. Several bridges with different approach designs should be selected, repaired as necessary, and monitored for five years to determine the effect of recommended maintenance practices on the decrease of water intrusion at bridge ends and resulting decrease in repair costs.

SI* (MODERN METRIC) CONVERSION FACTORS

APPROXIMATE CONVERSIONS TO SI UNITS

APPROXIMATE CONVERSIONS FROM SI UNITS

Symbol	When You Know	Multiply By	To Find	Symbol	When You Know	Multiply By	To Find	Symbol
LENGTH								
in	inches	25.4	millimeters	mm	millimeters	0.039	inches	in
ft	feet	0.305	meters	m	meters	3.28	feet	ft
yd	yards	0.914	meters	m	meters	1.09	yards	yd
mi	miles	1.61	kilometers	km	kilometers	0.621	miles	mi
AREA								
in ²	square inches	645.2	square millimeters	mm ²	square millimeters	0.0016	square inches	in ²
ft ²	square feet	0.093	square meters	m ²	square meters	10.764	square feet	ft ²
yd ²	square yards	0.836	square meters	m ²	square meters	1.195	square yards	yd ²
ac	acres	0.405	hectares	ha	hectares	2.47	acres	ac
mi ²	square miles	2.59	square kilometers	km ²	square kilometers	0.386	square miles	mi ²
VOLUME								
fl oz	fluid ounces	29.57	milliliters	mL	milliliters	0.034	fluid ounces	fl oz
gal	gallons	3.785	liters	L	liters	0.264	gallons	gal
ft ³	cubic feet	0.028	cubic meters	m ³	cubic meters	35.71	cubic feet	ft ³
yd ³	cubic yards	0.765	cubic meters	m ³	cubic meters	1.307	cubic yards	yd ³
NOTE: Volumes greater than 1000 l shall be shown in m ³ .								
MASS								
oz	ounces	28.35	grams	g	grams	0.035	ounces	oz
lb	pounds	0.454	kilograms	kg	kilograms	2.202	pounds	lb
T	short tons (2000 lb)	0.907	megagrams (or "metric ton")	Mg (or "t")	megagrams (or "metric ton")	1.103	short tons (2000 lb)	T
TEMPERATURE (exact)								
°F	Fahrenheit temperature	5(F-32)/9 or (F-32)/1.8	Celsius temperature	°C	Celsius temperature	1.8C + 32	Fahrenheit temperature	°F
ILLUMINATION								
fc	foot-candles	10.76	lux	lx	lux	0.0929	foot-candles	fc
fl	foot-Lamberts	3.426	candela/m ²	cd/m ²	candela/m ²	0.2919	foot-Lamberts	fl
FORCE and PRESSURE or STRESS								
lbf	poundforce	4.45	newtons	N	newtons	0.225	poundforce	lbf
lbf/in ²	poundforce per square inch	6.89	kilopascals	kPa	kilopascals	0.145	poundforce per square inch	lbf/in ²

* SI is the symbol for the International System of Units. Appropriate

TABLE OF CONTENTS

CHAPTER 1 - INTRODUCTION.....	1
1.1 Problem Statement	1
1.2 Research Approach	1
1.3 Report Organization	2
CHAPTER 2 – REVIEW OF TECHNICAL LITERATURE	3
2.1 Overview	3
2.2 Settlement of Bridge Approaches.....	3
2.3 Joint Repair and Joint Sealing	9
2.4 Surface and Subsurface Drainage.....	17
2.5 Bridge Approach Repair Strategies	22
CHAPTER 3 – SURVEY OF TXDOT DISTRICTS	29
3.1 Survey Procedure	29
3.2 Overview of Findings from Survey	29
3.2.1 Extent of Water Intrusion and Approach Slab Settlement Problems At Bridge Ends	29
3.2.2 Surface Drainage and Subsurface Drainage Systems Used to Prevent Water Intrusion.....	30
3.2.3 Approach Slab Details and Repair Techniques Used by TxDOT.....	31
CHAPTER 4 – DETAILED STUDY OF SELECTED BRIDGES	33
4.1 Visits to TxDOT Districts	33
4.2 Abilene District, US-83 Overpass at Antilley Road.....	33
4.2.1 Introduction	33
4.2.2 Site Description	33
4.2.3 Pavement History at Site	35
4.2.4 Site Reconnaissance	36
4.2.5 Pavement Condition and Seepage Area Observations	37
4.2.6 Field Investigation	38
4.2.7 Laboratory Testing of Samples	39
4.2.8 Data Interpretation and Proposing a Possible Mechanism	41
4.3 Lubbock District.....	43
4.4 Lufkin District	46
4.5 Houston District	57
4.5.1 US-290 (East Bound) Overpass at FM 362	58
4.5.2 US-290 (East Bound) Overpass at Kickapoo Road.....	59
4.5.3 US-290 (West Bound) Overpass at Hegar Road	59
CHAPTER 5 – SITE ASSESSMENT AND SELECTION OF OPTIMUM REPAIR STRATEGY	61
5.1 Introduction	61
5.2 Role of Water Intrusion in Bridge Approach Degradation.....	61
5.3 Controlling Water Intrusion	65
5.3.1 Controlling Surface Water Intrusion	67

	5.3.2 Controlling Subsurface Water Intrusion.....	70
5.4	Selection of Optimum Repair Strategy	77
	5.4.1 Design of the Bridge Approach.....	77
	5.4.2 Severity of Damage	77
	5.4.3 Interruption to Traffic.....	78
5.5	Bridge Approach Repair Methods.....	78
	5.5.1 Restoring Ride Quality with Asphalt Overlay.....	78
	5.5.2 Slab Stabilization.....	78
	5.5.3 Slab Jacking Using Cement Grouts.....	84
	5.5.4 Slab Jacking Using Polyurethane Foam.....	83
	5.5.5 Patching Approach Slabs.....	86
	5.5.6 Approach Reconstruction	90
CHAPTER 6 – CONCLUSIONS AND RECOMMENDATIONS		97
6.1	Conclusions	97
6.2	Recommendations	98
REFERENCES.....		99
APPENDICES		
	Appendix A	
	Appendix B	
	Appendix C	
	Appendix D	
	Appendix E	
	Appendix F	

LIST OF FIGURES

Figure 2.1	Cross-section showing wingwall and drainage detail (Taken from NCHRP Synthesis: 234, 1997).....	4
Figure 2.2	Schematic of a Conventional Bridge (Taken from “Integral abutment bridges: Problems and innovative solutions”, Horvath et. al.)	5
Figure 2.3	Integral abutment bridges (same source as above)	6
Figure 2.4	Seasonal Movement of Bridge Abutment (same source as above).....	6
Figure 2.5	Void development behind abutments in IAB’s.....	7
Figure 2.6	Application of compressible inclusions	7
Figure 2.7	IAB solutions, to simultaneously reduce lateral earth pressure on, and settlement adjacent to abutments	8
Figure 2.8	Penn DOT Joint Seal Rating Levels	12
Figure 2.9	Sealant Adhesion Failure	13
Figure 2.10	Full Depth Cohesion Failure.....	13
Figure 2.11	Joint seal testing by IA-VAC.....	14
Figure 2.12	Components of a highway edge drain.....	19
Figure 2.13	Rodent in Subsurface Drain.....	20
Figure 2.14	Subsurface Defects.....	25
Figure 2.15	URETEK deep injection process	26
Figure 4.1	Side View of Rip Rap with Washed-Out Fines at Toe	43
Figure 4.2	Top View of Rip Rap with Washed-Out Fines at Toe.....	44
Figure 4.3	Damaged Joint in Rip Rap Slab.....	44
Figure 4.4	Differential Settlement of Rip Rap Slab (Side View).....	45
Figure 4.5	Filter Fabric at Joint in Rip Rap Slab during Construction	45
Figure 4.6	Filter Fabric at Drain in Rip Rap Slab during Construction	46
Figure 4.7	Locations of Bridges Visited in The Houston District.....	58
Figure 5.1	Extensive Erosion at Business 69 Overpass over Southern Pacific Railroad in Lufkin District.....	63
Figure 5.2	Signs of Embankment Fill Erosion at IH-27 Overpass over 4 th Street in Lubbock District	64
Figure 5.3	Water Seepage at the US-83 Overpass Bridge Departure over Antilley Road in Abilene District	66
Figure 5.4	Drainage Plume at the Bridge End (Houston District)	68
Figure 5.5	Inadequate Rip-Rap Width (Houston District)	69
Figure 5.6	Badly Damaged Drainage Plume Allowing Water to Flow Underneath Approach Slab.....	71
Figure 5.7	Effectiveness of Drainage Plume Impaired by Weeds and Debris Collection.....	72
Figure 5.8	Entrance to Original Drainage Plume Blocked by the Installation of the Moncurb in the New Guardrail System	73
Figure 5.9	Poorly Maintained 5 in Wide Joint Between Bridge Deck and Approach Slab	74

Figure 5.10	An Access Point for Intrusion of Bridge Surface Runoff	75
Figure 5.11	Open Joint between Approach Slab and Mow Strip	76
Figure 5.12	URETEK Hyper Optics Void Detection System	79
Figure 5.13	GPR and Slab-IR Testing of Alpine Dam Spillway to Detect Voids Underneath Slab	80
Figure 5.14	Results from GPR and Slab-IR Tests Conducted on Alpine Dam Spillway	81
Figure 5.15	Borescope Stillshot	82
Figure 5.16	Multiple Overlays Used to Remedy Bridge End Settlement	83
Figure 5.17	Steps Involved in Slab Jacking	85
Figure 5.18	URETEK Slab Jacking Process	87
Figure 5.19	Slot- Stitching of a Concrete Slab Across a Crack	88
Figure 5.20	Precast Slab being Lowered into Place	89
Figure 5.21	Sawcut Prepared to Receive Polymer Insert	90
Figure 5.22	Precast Panel after the Repair has been Complete	91
Figure 5.23	Cross-Stitching Across a Crack	92
Figure 5.24	Bridge End Detail Showing Cement Stabilized Sand (CSS) Wedge Behind Abutment	93
Figure 5.25	Bridge End Detail Showing Subdrain System Used in the Houston District	95
Figure 5.26	Bridge End Detail Showing Subdrain System Used in the Lufkin District	96

LIST OF TABLES

Table 2.1	Concrete pavement/joint survey form	10
Table 2.2	Decision Table for resealing PCC Joints	11
Table 4.1	Moisture Content Variation with Depth for Bore Hole 1	39
Table 4.2	Moisture Content Variation with Depth for Bore Hole 2	39
Table 4.3	Moisture Content Variation with Depth for Bore Hole 3	40
Table 4.4	Field Density and Degree of Saturation Measurement for Bore Hole 1	40
Table 4.5	Field Density and Degree of Saturation Measurement for Bore Hole 2	41
Table 4.6	Field Density and Degree of Saturation Measurement for Bore Hole 3	41

CHAPTER 1

INTRODUCTION

1.1 Problem Statement

The Texas Department of Transportation (TxDOT) maintenance sections spend a considerable amount of time and money repairing pavement failures that occur in the base or subgrade materials near bridge ends. Investigations of these failures often reveal saturated base/subgrade materials. An earlier TxDOT research project (Project 0-4147) investigated settlements at bridge approach slabs by concentrating on design features for new construction. The earlier study determined that the quality of the embankment materials for approach slabs suffering settlement problems was very poor with a high plasticity index and the compaction was substandard. The study recommended the use of better quality soils for the embankment, higher levels of compaction, stabilized wedges behind the abutments, and drain systems behind the abutment and along the wing walls. Recommendations from the earlier study pertained to new construction.

The objectives of the research study reported herein were to determine all possible sources for water intrusion at bridge ends, develop methods to help recognize in-the-field causes of water collection at bridge approaches, and to develop new repair methods that can be economically implemented in the field to minimize water intrusion or remove water from soils to maintain a stable foundation without settlement. The repair methods were to include new materials, soil reinforcement, drainage designs or combinations to minimize water intrusion, provide stable foundations, and provide long term repairs to existing bridge approaches. This research project focused on existing bridge approaches and concentrated on maintenance techniques to prevent water intrusion at bridge ends.

1.2 Research Approach

The research team accomplished an extensive literature review to determine all possible sources for water intrusion at bridge ends. During the literature review, several state departments of transportation agencies were contacted for additional information on design features such as drainage systems and repair techniques. Researchers surveyed each of the TxDOT districts to gather observations about major factors contributing to the problem of water intrusion and settlement at bridge ends. Based upon information from the survey of TxDOT districts, four districts were visited for field investigations to observe and document causes for water intrusion and discuss methods for preventing water intrusion. The US 83 overpass over Antilley Road in Abilene was selected for further field investigation and data collection because of a persistent water intrusion and seepage problem. Based upon the information collected, researchers developed a site assessment technique to evaluate the potential of a particular site to incur water intrusion, and methods to develop optimum repair strategies. The study collected a number of construction/maintenance items, details and specifications regarding prevention of water intrusion at bridge ends. These details and specifications are presented in the appendices to this report.

1.3 Report Organization

This report documents findings and recommendations from the research project. Following the introduction in Chapter 1, Chapter 2 presents the results from an extensive literature review. Topics within the literature review include a description of water intrusion and approach slab settlements at bridge ends, design features such as surface drainage and sub-surface drainage systems, maintenance practices important to preventing water intrusion, and existing repair strategies. Miscellaneous details associated with this literature review are found in Appendix A. A summary of responses from the survey of TxDOT districts is presented in Chapter 3. Survey questions and responses are given in Appendix B and TxDOT design items, details and specifications are given in Appendix C. During the study, several bridge sites were visited and field tests were conducted to identify water intrusion problems at one bridge in the Abilene district. Chapter 4 presents observations from the field visits. Chapter 4 also presents and discusses the field data collected on the Abilene bridge and identifies possible sources of water collected in the bridge embankment. Field data from the investigation of this bridge are found in Appendix D. The research team developed a technique for assessing bridge ends for possible water intrusion problems and optimizing repair strategies. Chapter 5 presents a description of the site assessment technique and the logic associated with its development. Finally, the report concludes with recommendations for an implementation project to demonstrate the application of products from the study.

CHAPTER 2

REVIEW OF TECHNICAL LITERATURE

2.1. Overview

A comprehensive review of pertinent technical literature was conducted as a part of this research project and the findings are listed in this chapter. The literature reviewed can broadly be divided into the five major categories listed below. Accordingly, this chapter has been divided into five sub-chapters and the findings from each category have been listed under the respective headings.

1. Overview
2. Settlement of Bridge Approaches
3. Joint Repair and Joint Sealing
4. Surface and Subsurface Drainage
5. Bridge Approach Repair Strategies

2.2. Settlement of Bridge Approaches

Although several technical reports have been published addressing the problem of ‘bump’ at the end of bridges, no significant published literature on water intrusion at bridge ends was encountered. However, almost all the works on the bump problem have listed bridge approach drainage as one of the most important factors contributing towards bump development and also towards the approach failure at bridge sites. The following quote comes from the conclusions of Chini et al (*Drainage and Backfill Provisions for approaches to Bridges, 1993*). “*The development of approach faults has often contributed to surface and sub surface erosion of the soil adjacent to the abutment and under the approach pavement. Therefore, special attention must be given to remove water from critical areas around the abutments and under the approach pavements by providing an adequate drainage system.*” Some of the most significant studies addressing the ‘bump problem’ were reviewed to assess the prevailing drainage problems at bridge sites.

The most significant work addressing the bump problem is NCHRP Synthesis Study 234 (“*Settlement of Bridge Approaches*”). This synthesis identifies and describes techniques that have been used to reduce the bump problem at bridge ends. This is based on a literature review, the responses to a survey questionnaire of 72 engineers from 48 state departments of transportation and discussions with other DOT engineers. This synthesis lists the most commonly reported causes of the bump (in the order of importance):

1. Compression of the fill material
2. Settlement of the natural soil under the embankment
3. Poor construction practices
4. High traffic loads
5. Poor drainage
6. Poor fill material
7. Loss of fill by erosion

- 8. Poor joints
- 9. Temperature cycles

It should be noted that although drainage is listed as only one component in the above list, water intrusion can be associated to several of the components. Water getting into the soil can magnify the settlement of the soil under the embankment. Poor construction practices can lead to opening through which water can get into the base/Subgrade material hence causing loss of fill by erosion. Poor drainage and poor joints are direct causes that result in water intrusion into the base/Subgrade material. Hence it will be natural to assume that preventing the water from getting into the underlying soil at bridge ends will contribute significantly towards the reduction of the bump problem. Apart from that, water intrusion accelerates the deterioration of structural elements of bridges like the approach slab and the riprap slab.

NCHRP synthesis 234 recommends the installation of appropriate drainage systems to keep water from collecting behind the abutment or eroding the fill from behind the abutment. It suggests that the surface run-off should be routed away from the bridge/approach joint. One recommendation towards an appropriate surface drainage system is to place the wing-walls beyond the bridge end panels (Bellin, J., *Bridge drainage and bridge end panels*, 1993). Another recommendation is to have a pavement wing-wall assembly as shown in Figure 2.1.

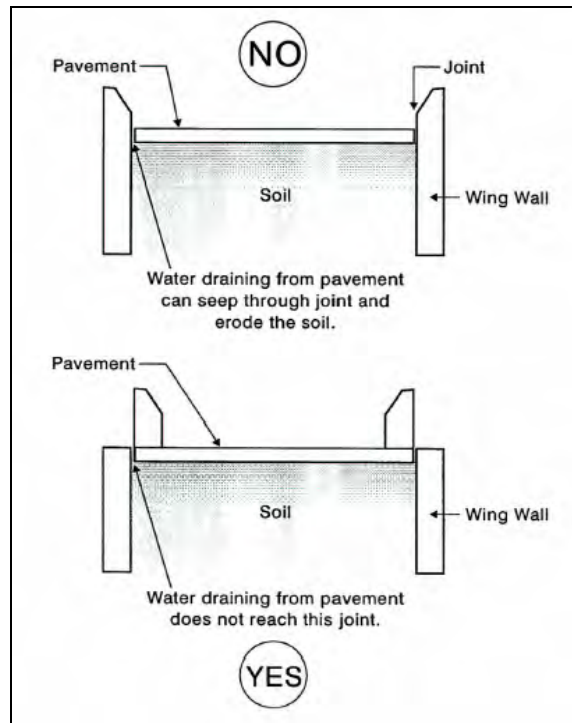

Figure 2.1: Cross-section showing wingwall and drainage detail (Taken from NCHRP Synthesis: 234, 1997)

Overall, this synthesis recognizes the importance of keeping the water from infiltrating into the soil beneath the approach slab and behind the abutment. The reduction in the amount of water infiltrating will reduce the erosion of material which in turn will contribute towards a reduction in the bump problem.

Integral Abutment Bridges

Another common approach for minimizing water infiltration into the subsoil at bridge ends is the use of Integral Abutment Bridges. The basic design philosophy behind conventional bridges is to make the bridge as unconstrained as practical to prevent the thermally induced loads from developing within the superstructure. This is normally done by creating a physical gap called an ‘expansion joint’ between the bridge superstructure and the abutments at each end. The abutments are then constructed more or less as conventional retaining walls (either rigid or cantilever) to retain the soil. The expansion joints accommodate the thermal movement of the bridge slabs and also ensure that the lateral earth pressure on the abutments does not change due to seasonal expansion of the structure. But the main problem with the conventional type bridge construction is the maintenance aspect of the expansion joints introduced. The joints present a potential location for water intrusion as well as other deleterious material into the subsoil. Fines getting into the expansion joints prevent the bridge super structure from expanding and introduce thermally induced cracks. Water getting into the subsoil erodes the soil from underneath the bridge approach slab causing loss of support for the slab. If the approach slab is not designed to resist load in an unsupported condition, cracks will form and also the bridge approach slab will settle with respect to the bridge deck, forming the “bump” at the end of the bridge. One solution to this problem is to connect the bridge abutment and the superstructure both physically and structurally. This concept (Integral Abutment Bridge, IAB) was first introduced in order to avoid the post construction maintenance and expense requirements faced in conventional bridge structures. The following figures demonstrate the fundamental difference between a conventional bridge having expansion joints and an integral abutment bridge.

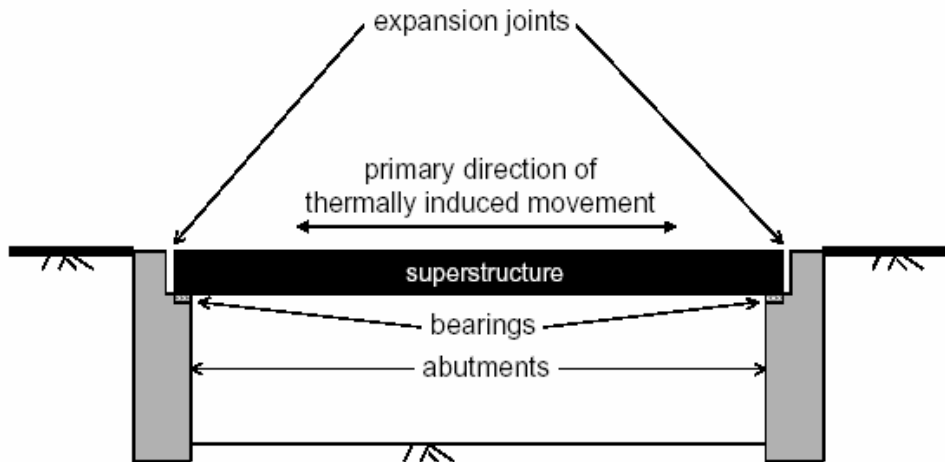

Figure 2.2: Schematic of a Conventional Bridge (Taken from “Integral abutment bridges: Problems and innovative solutions”, Horvath et. al.)

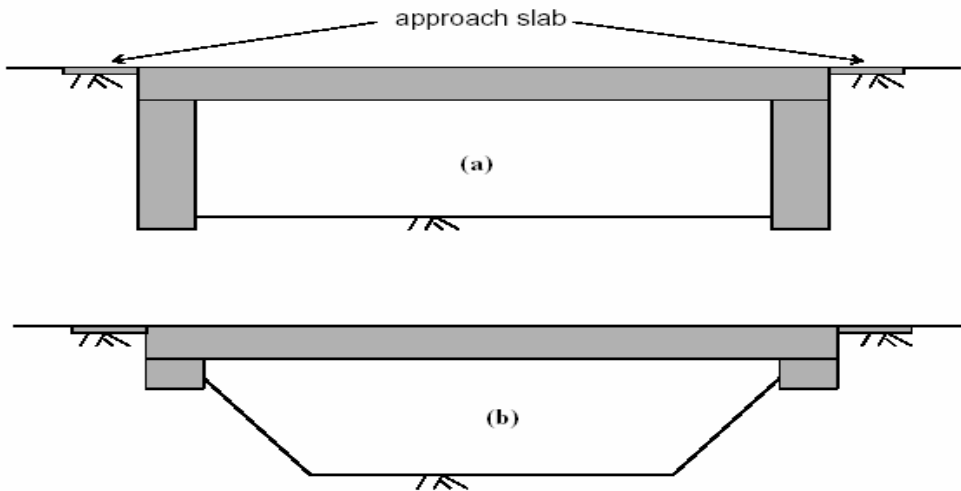
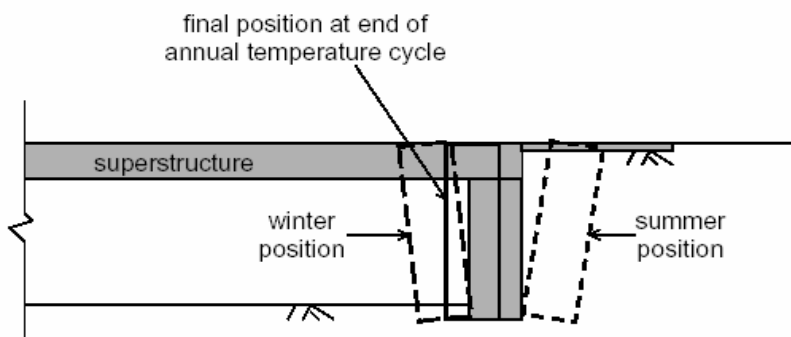

Figure 2.3: Integral abutment bridges (Taken from the same source as above)

The use of IABs has significantly reduced the problems related to the maintenance and repair of expansion joints. The elimination of expansion joints ensures that the number of potential locations for water intrusion is reduced. This reduces the amount of erosion from underneath the approach slabs and thereby increases the life of the approach slabs significantly. However, the main problem observed in the case of IABs is the relative movement between the bridge structure (including the abutments) and the retained soil. The temperature increase in summer causes the bridge structure to expand and push against the soil retained behind the abutments. During the winters, the abutment moves away from the soil as the structure shrinks. At the end of each temperature cycle, there is a net movement of the abutment away from the soil, which creates a void just behind the abutment and results in loss of support for the bridge approach slab. The following figure demonstrates the problem most commonly observed in the case of integral abutment bridges.



Note: Initial abutment position at start of annual temperature cycle shown by shaded area.

Figure 2.4: Seasonal Movement of Bridge Abutment (same source as above)

During the winter contraction of the bridge structure, a wedge shaped portion of the retained soil moves towards the abutment. However, this soil wedge is not pushed back to its original position during the summer expansion. This is mainly due to the non-linear behavior of soil. This effect tends to accumulate over the years and the net result of this accumulation is the creation of a void just behind the abutment. Figure 2.5 shows the void development behind the abutment.

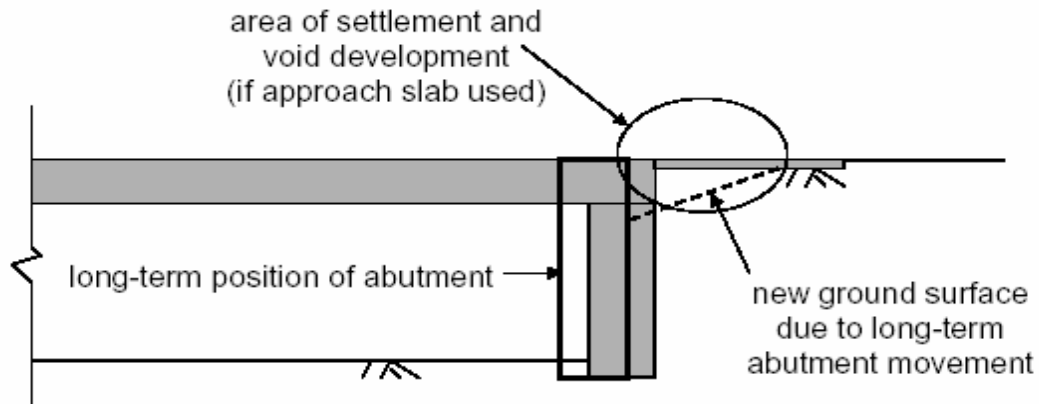

Figure 2.5: Void development behind abutments in IAB's (same source as above)

There have been several strategies, suggested to fix the above mentioned problem, associated with integral abutment bridges. One earlier complete structural approach was to reduce the height of each abutment considerably. Although the lateral earth pressure acting on the abutment still increased every summer, the total resultant force and flexural stresses that the abutment should be designed to resist, reduced significantly because of the smaller span. Another more geotechnical approach involved the concept of placing a compressible inclusion (i.e. a material placed in the ground, which is significantly more compressible than the material adjacent to it). One example of a commonly used compressible inclusion is expanded polystyrene (EPS) geofoam. Recycled tire fragments have also been tried as compressible inclusions, but their behavior has been found to be unpredictable and they have been found to be environmentally problematic. Figure 2.6 demonstrates the application of compressible inclusions behind the bridge abutment.

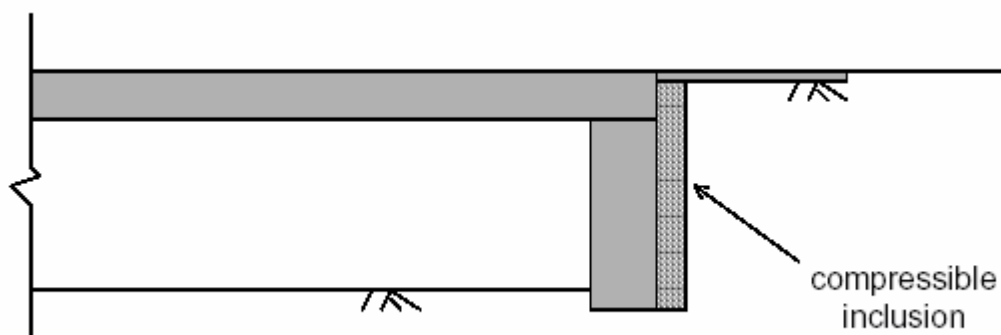

Figure 2.6: Application of compressible inclusions

However, research has indicated that, although compressible inclusions have successfully reduced the lateral earth pressures on the abutments, they have been ineffective in controlling the settlement behind the bridge abutments. So, a complete solution to IAB problems needs to address both the lateral earth pressure and settlement issues simultaneously. Several design concepts have been considered to achieve these goals. One approach is to keep the mass of retained soil stable by using geosynthetic tensile reinforcement and building a mechanically stabilized earth mass. A second approach involves the use of a wedge-shaped mass of EPS block, which acts as a wall on its own, and reduces the lateral pressure on the abutment as well as the settlement behind the bridge abutments. Figure 2.7 presents a schematic diagram of the two solutions discussed.

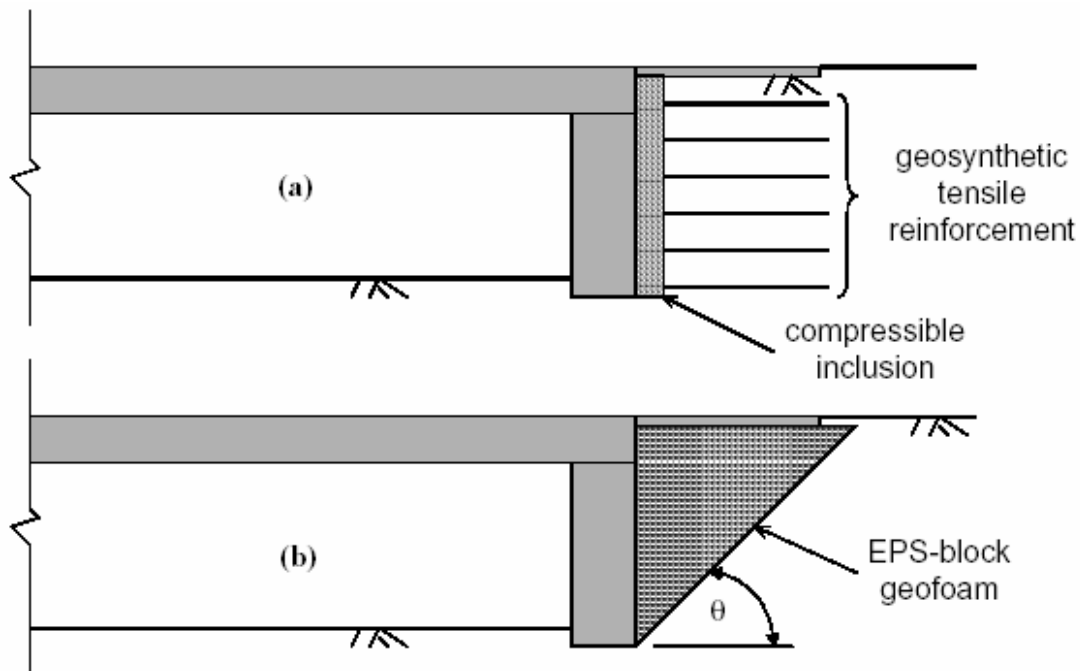

Figure 2.7: IAB solutions, to simultaneously reduce lateral earth pressure on, and settlement adjacent to abutments (same source)

Although these approaches sound promising towards solving the problems associated with integral abutment bridges, more research is recommended in this field to validate the claims by physical testing and observations. So, the use of integral abutment bridges can be considered as an option while constructing new highway bridges.

2.3. Joint Repair and Joint Sealing

Joints in pavements are one of the most significant sources of water intrusion into the base/subgrade. In order to prevent the water and incompressible material from getting into the subsoil through the joint openings and thereby deteriorating the pavement, maintaining the joint seals in good condition is crucial. Although not enough literature was found on the sealing of bridge approach joints, several research papers have been published addressing the sealing of concrete pavement joints. The principles of sealing and maintaining joints on both bridge approach slabs and concrete pavements are the same. This section addresses two aspects of pavement joint sealing. In the first part, preventive maintenance of joint seals is talked about. In the second part, repair and resealing of already failed pavement joints is discussed.

The most widely accepted definition of a joint sealant today is a material that minimizes both infiltration of surface water and incompressible material into the joint system. There are basically three categories of sealants: hot-poured liquid sealants, cold-poured silicone sealants and preformed compression sealers. Although joint seals in pavements are usually designed to last throughout the life of the pavement, unfortunately it is not practical to construct and continually maintain a completely watertight pavement. All pavement sealants have been observed to accumulate distress and crack over time. Moisture entering the pavement subsurface through these joints/cracks can soften and erode the sub-base or subgrade. The resulting loss of support from underneath the pavement/approach slab leads to settlement and/or faulting of the slab. Incompressible materials entering through the joints can cause joint spalling, blowups, buckling and slab shattering. Therefore it is only by regular inspection and maintenance that adequate performance of the pavement joints can be ensured.

In order to ensure adequate performance throughout the life time of the bridge approach slab, preventive maintenance of the joints needs to be carried out. Excessive delay in repairing/replacing a failing sealant can result in rapid deterioration of the approach slab. On the other hand, replacing the joint sealants too frequently means inefficient utilization of precious maintenance funds. Therefore, there has to be a balance between the quality of joints to be maintained and the amount of money spent for this purpose. The decision whether joint seals need to be replaced, is often made based on some kind of a rating threshold or state specifications. For example, some states specify that the joint sealants should be replaced when a specified portion of the joint sealant (usually 25 to 50 percent) has failed thereby allowing water and incompressible material to get into the subsoil. A more complete method for determining whether a pavement needs resealing is by calculating a rating number based on the pavement condition, sealant condition, traffic level and climatic conditions. The condition of the sealant system is judge by the ability of the joint seal to prevent inflow of water and incompressible material into the subsoil. A sample worksheet for calculating this rating number is given below. The table following the figure gives the recommendations for such a rating system.

Table 2.1: Concrete pavement/joint survey form (from FHWA Report No. FHWA-RD-99-146)

Seal Condition				Pavement Condition			
	Low	Med	High		Low	Med	High
Water entering, % length	< 10	10-30	> 30	Expected Pavement Life, yrs.	> 10	5-10	< 5
Stone intrusion	L	M	H	Average faulting, mm	<1.5	1.5-3.0	>3.0
Seal Rating	Good	Fair	Poor	Corner breaks, % slabs	< 1	1-5	> 5
Environmental Conditions				Pumping, % joints	< 1	1-5	> 5
				Spalls >25 mm, % slabs	< 5	5-10	>10
Avg annual precip., mm				Pavement Rating	Good	Fair	Poor
Days $\leq 0^{\circ}\text{C}$				Current Joint Design			
Avg low / high temp, $^{\circ}\text{C}$							
Climatic Region ^a	WF DF	WNF DNF		Sealant age, yrs			
Traffic Conditions				Avg. sealant depth, mm			
				Avg. joint width, mm			
ADT (vpd); % Trucks				Avg. joint depth, mm			
Traffic Level ^b	Low	Med	High	Max. joint spacing, m			

^a refers to the different climatic regions listed in the referenced report

^b refers to the different traffic levels listed in the referenced report

Table 2.2: Decision Table for resealing PCC Joints
(from the same source as above)

Sealant Rating ^a	Pvmt. Rating	Traffic Rating	Climatic Region			
			Freeze		Nonfreeze	
			Wet	Dry	Wet	Dry
Fair	Good	Low	Possibly	Possibly	Possibly	Possibly
Fair	Good	Med	Yes	Possibly	Possibly	Possibly
Fair	Good	High	Yes	Yes	Yes	Possibly
Fair	Fair	Low	Yes	Possibly	Possibly	Possibly
Fair	Fair	Med	Yes	Yes	Yes	Possibly
Fair	Fair	High	Yes	Yes	Yes	Possibly
Fair	Poor	Low	Possibly	Possibly	Possibly	Possibly
Fair	Poor	Med	Yes	Yes	Yes	Possibly
Fair	Poor	High	Yes	Yes	Yes	Yes
Poor	Good	Low	Yes	Possibly	Possibly	Possibly
Poor	Good	Med	Yes	Yes	Yes	Possibly
Poor	Good	High	Yes	Yes	Yes	Yes
Poor	Fair	Low	Yes	Yes	Yes	Possibly
Poor	Fair	Med	Yes	Yes	Yes	Yes
Poor	Fair	High	Yes	Yes	Yes	Yes
Poor	Poor	Low	Yes	Yes	Yes	Possibly
Poor	Poor	Med	Yes	Yes	Yes	Yes
Poor	Poor	High	Yes	Yes	Yes	Yes

^a Sealants rated in "Good" condition do not require replacement.

Another example of a rating system for joint seal conditions is, the rating scale developed by Pennsylvania Department of Transportation. This scale, shown in Figure 2.8, has a rating of 1 to 5 in three categories: sealing, weathering and debris intrusion.

Joint Seal Rating Levels		
<u>Rating</u>	<u>Degree</u>	<u>Description</u>
<u>Sealing</u>		
5	None	Seal is intact and in the same condition as constructed.
4	Slight	Seal has experienced adhesion, cohesion, and/or raveling defects in less than 5 percent of the joint length.
3	Moderate	Seal has experienced adhesion, cohesion, and/or raveling defects in less than 25 percent, but more than 5 percent of the joint length.
2	Severe	Seal has experienced adhesion, cohesion, and/or raveling defects in less than 50 percent, but more than 25 percent of the joint length.
1	Deteriorated	Seal has experienced adhesion, cohesion, and/or raveling defects in more than 50 percent of the joint length.
<u>Weathering</u>		
5	None	Seal is intact and in the same condition as constructed.
4	Slight	Seal surface aged or oxidized.
3	Moderate	Seal surface has weather checking.
2	Severe	Seal surface has alligator cracking.
1	Deteriorated	Seal surface has eroded.
<u>Debris Intrusion</u>		
5	None	Seal is intact and in the same condition as constructed.
4	Slight	Seal is intact and in the same condition as constructed with debris accumulated, but no intrusion.
3	Moderate	Seal has accumulated debris with scattered intrusion.
2	Severe	Seal has accumulated debris with much intrusion.
1	Deteriorated	Seal is broken and eroded by excessive intrusion of debris.

Figure 2.8: Penn DOT Joint Seal Rating Levels

Joint sealants split open either by losing bond with the sidewalls of the joint reservoir (Figure 2.9), by losing internal bonding (Figure 2.10) spalling and torn/missing sealant. Case studies have shown that the predominant distresses in pavement joints sealants are adhesion loss and spall failure.

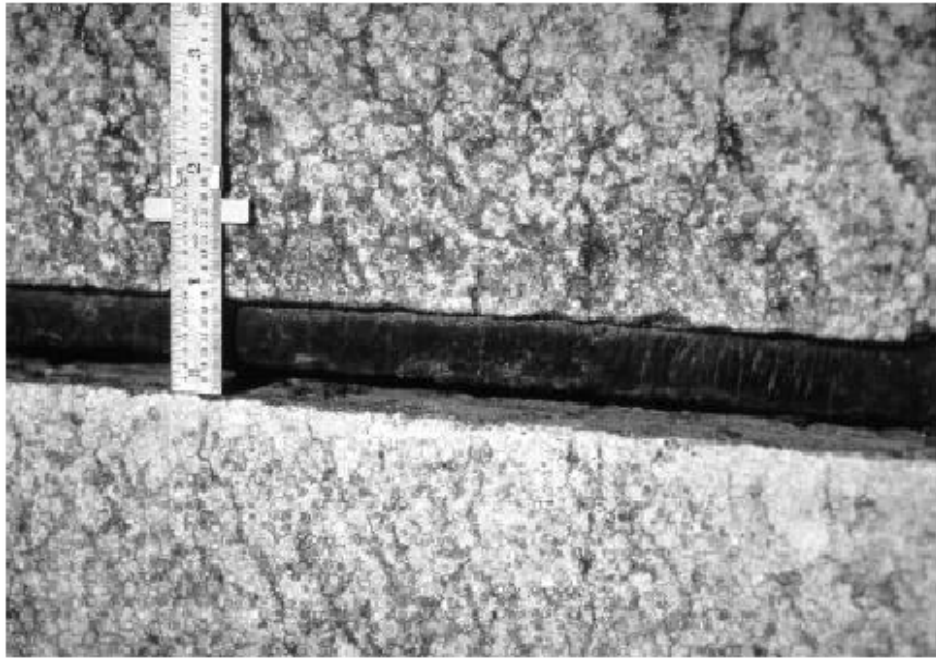

Figure 2.9: Sealant Adhesion Failure
(Taken from FHWA Report No. FHWA-RD-99-146)

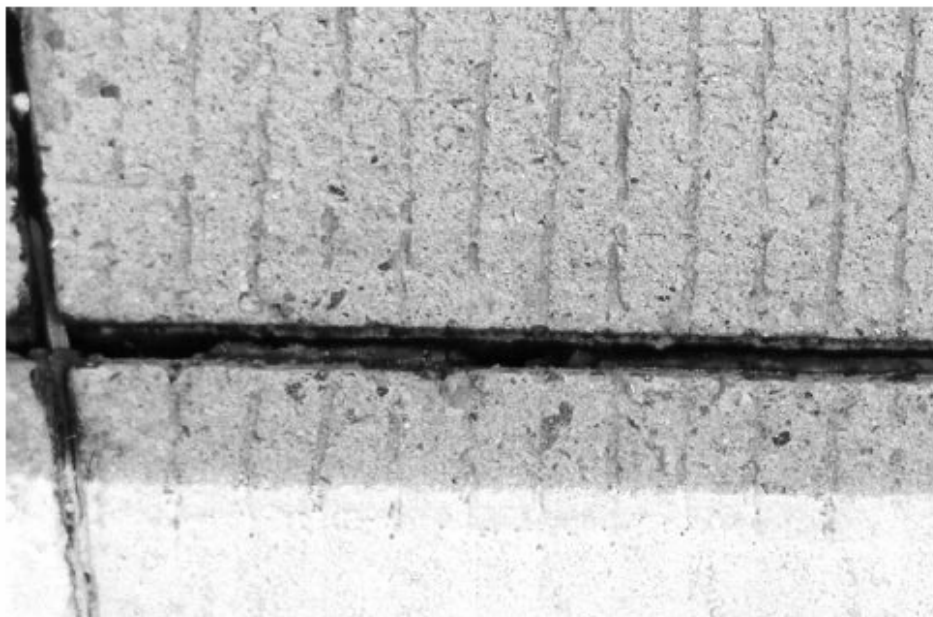

Figure 2.10: Full Depth Cohesion Failure
(Taken from FHWA Report No. FHWA-RD-99-146)

Bond failure can be determined by pulling the sealant from the joint and inspecting for adhesive failure. Full depth spalls can be identified by gently inserting a dull knife into the spall and observing whether the knife can pass below the sealant. Another method to determine the condition of the joint sealant is by using the Iowa vacuum tester (IA-VAC) developed by the Iowa Department of Transportation. The IA-VAC is an innovative vacuum joint sealant testing device that detects unseen leaks in joint seals. This is accomplished by spraying the joint and surrounding pavement surface with a soap/water solution, placing the chamber over the pavement surface, and applying a vacuum over the seal. Air bubbles indicate seal leakage. Figure 2.11 shows the testing of a pavement joint by IA_VAC.

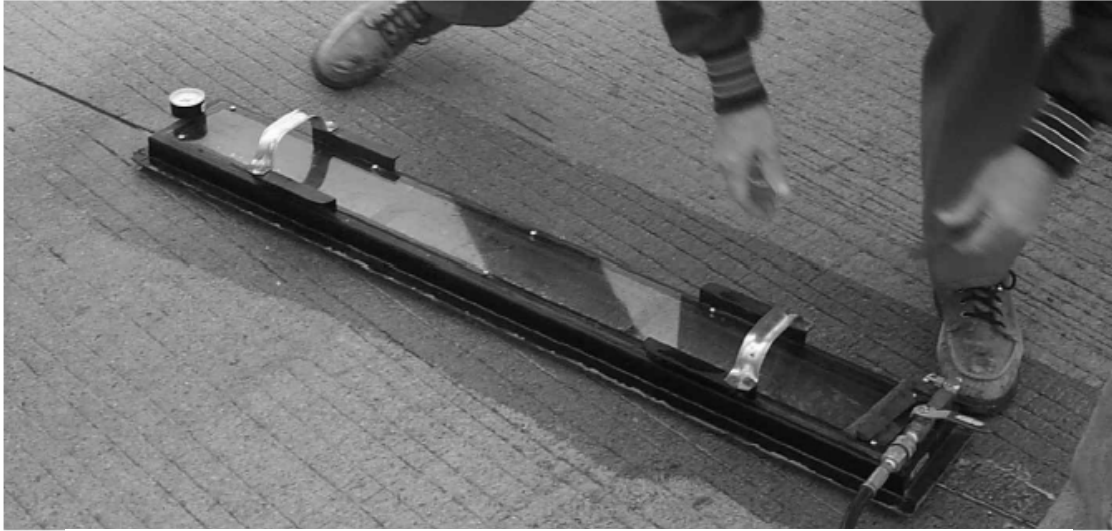

Figure 2.11: Joint seal testing by IA-VAC (Taken from “Edge joint sealing as a preventive maintenance, MnROAD, 2003)

Whether the sealing system on a pavement is functioning adequately or not, can be determined from several indicators provided by the pavement. Some of the most common indicators of joint failure are listed below.

- Surface staining, or the accumulation of fines on the surface next to the joint, indicates pumping of fines from under the slab and ultimately leads to large void generation below the slab.
- Faulting or settlement between adjacent slabs indicates water intrusion into the subsoil and void creation underneath the slab
- D-cracking often results from excess moisture under the slab
- Compression related spalling of the joints
- Blow-ups and shattering of the slab edges and/or permanent increase in the width of expansion joints

Similarly, traffic levels and climatic conditions should be considered when evaluating a pavement joint system. Evaluation of the pavement joint system should be conducted on a regular basis in order to ensure that the joint is repaired before failing excessively.

If evaluation of the sealing system shows that the pavement needs resealing, one of the several methods available for joint sealing has to be selected. Some of the most common

generic joint sealing systems are discussed below. (*an evaluation of bridge deck joint sealing systems in Virginia*)

- a. **Field Molded Seals:** This system consists of a self-leveling sealing material that is poured into the joint. A closed cell foam backer rod placed in the joint below the sealer supports it until it has cured. After curing, the sealing material remains flexible to accommodate horizontal and vertical movements. This system is commonly used where joint movement is 3/16 inch or less.
- b. **Open Cell Compression Seal:** These are neoprene rubber strip members that are rectangular in cross section with various configurations of internal diagonal and vertical webs. The seals are placed in the expansion joint while in compression with the aid of a lubricating adhesive, which cures to bond the sides of the seal to the joint faces. Compression seals can accommodate joint movements ranging from ¼ to 2 1/2 inches.
- c. **Closed Cell Compression Seal:** A low-density closed cell foam rectangular-shaped strip member is compressed into the joint with an elastomeric primer to function in a manner similar to that of the open cell compression seal. Unlike liquid sealants, which stretch when the joint opens, preformed compression seals remain compressed throughout cycles of joint opening and closing. Therefore, their ability to remain in the reservoir and their long-term success depends primarily on the lateral pressure the seal exerts on the reservoir.
- d. **Strip Seal:** These are V-shaped strips of elastomeric materials, which are generally mechanically locked to metal retainer members at the edges of the expansion joint. These can accommodate movements up to 4 inches.
- e. **Plug Seal:** These are deformable polymer-modified asphalt concrete material placed in a cutout area over the expansion joint at the deck surface. A backer rod is compressed into the joint opening below the cutout, and the entire blocked out area is sealed with the binder material used in the mix. A plate placed over the joint opening and sealed with the binder material, supports the elastomeric asphalt layer, which accommodates the movement of the deck. Plug seals can accommodate joint movements of 2 inches.
- f. **Inflatable Neoprene Seal:** In this system of joint sealing, a preformed open cell neoprene strip member is bonded to the edges of the expansion joint and the seal (which is sized to match the midrange joint opening) is inflated to ensure a positive seal with the joint face. Inflation is maintained during the entire curing time of the adhesive and the seal is then allowed to deflate as the air bleeds out.

The above discussed methods can be used for sealing of new pavement joints as well as for resealing already failed joints. Successful resealing of joints consists of the following five steps.

1. Removing the old sealant
2. Shaping the reservoir
3. Cleaning the reservoir
4. Installing the backer rod
5. Installing the sealant

Removing the old sealant and cleaning the joint faces provides a surface for the new sealant to bond. The old sealant can be removed by manual removal, sawing, plowing or cutting. Irrespective of which method is adopted, care should be taken to ensure that the joint reservoir is not damaged during the process.

Shaping of the reservoir is necessary if the existing reservoir does not provide adequate dimensions for the new sealant. Reservoir faces should be cleaned thoroughly (removing all dust, dirt and traces of old sealant) to ensure good bonding with the sealant material. However, the extent to which the reservoir can be cleaned depends on the reservoir width. Use of chemical solvents to clean is not advisable as they can carry contaminants into pores and surface voids on the reservoir faces and thus inhibiting firm bonding of the new sealant material. Proper cleaning requires mechanical action and pure water flushing to remove any contaminants. Proper entrance of sealant into the joint should be ensured by air blasting the joint and pavement surface to remove sand, dirt and dust just before pumping the sealant

Backer rods (compatible with the sealant material and having a diameter about 25% greater than the reservoir width) should be installed after cleaning the joint but before installing the liquid sealant. Irrespective of whether the sealant material use is a liquid sealant or a compression sealant, it should be installed by following the manufacturer's guidelines, to achieve optimum sealant adhesion.

2.4. Surface and Subsurface Drainage:

Adequate surface and subsurface drainage is vital towards the performance of a pavement/bridge approach structure. Removal of excess surface and ground water plays an important role in governing the stability and/or serviceability. Earlier, drainage was regarded by many as an inescapable nuisance, but not a problem. Engineers seemed to view drainage difficulties as something to be prevented if possible but did not regard it as an important aspect of the design. However, gradually researchers started recognizing drainage as a fundamental factor in most pavement performance related problems. Hence design of adequate surface as well as subsurface drainage near bridge/pavement structures has been emphasized upon by all the state departments of transportation. Some of the most common drainage related distresses observed in pavement/bridge structures are: erosion, infiltration of soil, flow obstructions, depression and ponding areas. Several technical papers published on the evaluation of existing bridge drainage designs and recommendations on new design strategies were reviewed and their summary has been given in this chapter. Several different drainage features have been discussed along with a detailed discussion on pavement edge drains.

A complete bridge drainage system consists of a Bridge Deck Drainage System (BDDS) and a Bridge End Drainage System (BEDS). The BDDS includes all drains located on the bridge deck and the means used to convey the water collected by these drains. The 'BEDS' (also called 'bridge approach drainage') intercepts drainage immediately upslope and downslope of the bridge. Bridge approach drainage can basically be divided into two categories: **surface drainage** and **subsurface drainage** depending on whether the water is above or below the surface of the ground when it is first intercepted or collected. The

design of surface drainage systems aims at removing all the surface water away from the structure as soon as possible and not allowing ponding or delayed runoff of water, thus preventing any infiltration of the surface water into the subsoil. However, it has been observed that it is not always possible to remove the surface water immediately and hence part of it always enters the subsoil through joints/cracks in the pavement structure. In order to prevent the water that has already entered the subsoil from saturating the base/subgrade and causing pavement failure, the design of subsurface drainage features is important. A summary of past research findings on surface and subsurface drainage near bridge structures has been given in this chapter. Several drainage options have been mentioned and a detailed discussion on pavement edge drains is given.

Surface Drainage

Surface drainage provides for the interception, collection and removal of surface runoff. The surface water should be removed quickly and completely from the bridge deck and its vicinity. The first evidence of a poor drainage system usually is ponding on the roadway. Water should not be allowed to pond on pavements because it interferes with effective and convenient use of traveled areas and introduces hazards such as skidding or loss of steering and brake control. Examples of surface drainage features include shoulders, swales, gutters, ditches, channels, terraces and dikes, inlets, manholes, culverts, detention ponds and infiltration or leaching basins. The surface drainage features are usually designed keeping in mind the climate of the location, slope of the roadway and traffic on the road.

By observing the performance of several bridge-deck drainage systems, researchers have arrived at some suggestions regarding the design and construction of these features. Bridge deck and adjacent roadway drainage should be collected and dropped into a channel by means of drains similar to the gutter downspouts on houses. Drains should not be discharged directly on the faces of the approach slopes. When a deck drain is permitted to drain through short vertical pipes over the abutment slope, splash blocks should be placed directly under the drainage pipe to dissipate the energy of the falling water and prevent erosion of the fill. A deck drain is generally permitted to drain through short vertical metal pipes and spill directly into the abutment slope or run down the abutment wall through joints between the bridge deck and road surface. These practices initiate erosion on the abutment slope and piping from under and behind the abutment and cause cracking and settlement of the approach pavement. The catch basins for collecting the runoff water from bridge decks should be made wide enough to accommodate all the water on the bridge. The catch basins should be cleaned at regular intervals such that debris does not block the flow path of the surface water.

Subsurface Drainage: No matter how well designed and maintained the surface drainage system is, there is always some flow of ground water into the base course or subgrade. Subsurface drainage systems should be provided to intercept, collect and remove this water that gets into the subsoil. In places where it is required, subsurface drainage can be used to lower high-water tables, drain water pockets or perched water tables. A subsurface drainage system essentially consists of facilities to collect and dispose of water that occurs below the surface of the ground. Subsurface drainage

facilities include permeable bases, longitudinal edge drains, transverse drains, daylighted permeable bases, underdrains and retrofitted edge drains for existing pavements.

Out of several available alternatives, the most widely used subsurface drainage features are: edge drains and permeable bases. Other surveys have shown that permeable bases become infiltrated with fines from underlying layers. A high permeability drainage layer is normally used to remove free water from the pavement structure either vertically or laterally to the system of drainage pipes. This type of a drainage layer is normally constructed by using coarse materials surrounded by filters. Some states use asphalt-treated permeable material or cement-treated permeable material as drainage layer. Wahls (*NCHRP synthesis of highway practice 159: Design and construction of Bridge approaches, TRB, 1990*) has suggested the use of gutters and paved ditches to direct surface water away from the bridge approach system. Chini et al. suggest including a drainage layer to direct the water away from the abutment and installation of subsurface drainage pipes to collect the water from the drainage layer and transport to a collection point outside the roadway limits.

Pavement Edgedrains: NCHRP Synthesis 285 defines a pavement edgedrain as ‘A subsurface drain usually located at the edge of the pavement (between the travel lane and the shoulder) at an appropriate depth to intercept and remove infiltrated water from the pavement section. Researchers have emphasized the difference between an edgedrain and a pavement underdrain. Whereas edgedrains are meant to intercept water getting into the pavement subsurface from top, underdrains are deep subsurface drains located alongside the roadway at a sufficient depth and are meant to intercept and lower the groundwater to a required design level. Figure 2.12 shows the main components of an edgedrain.

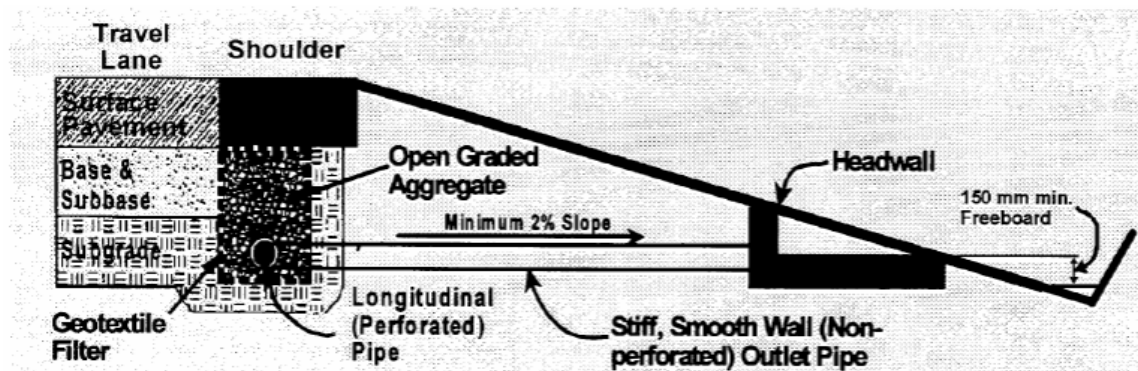

Figure 2.12: Components of a highway edgedrain (Taken from NCHRP Synthesis 285, 2000)

On already existing pavements not constructed with edgedrains, retrofit edgedrains can be installed to improve the drainage as well as overall pavement performance. States like Kentucky, Minnesota and Virginia have reported significant success in installing retrofit edgedrains (NCHRP Synthesis 285).

Surveys conducted by several researches have shown that benefits of installing pavement edgedrains are widely recognized. However, only proper design or installation of edgedrains does not ensure adequate performance of the pavement throughout its design

life. Without regular inspection and maintenance, edgedrains can even prove more harmful to the pavement. Surveys in the past have shown that only one-third of the edge drains in existing pavements function as designed. The main problems associated with edgedrains are: vegetative growth, debris and fines discharging from the pavement system. In some instances, inspection by a snake camera has even shown the edgedrain outlet pipes to be blocked by rodent nests (Figure 2.13).

Maintenance and Repair Strategies for Drainage Structures: Drainage problems do not have any one time solution. Though properly designed constructed and maintained drainage structures can solve a majority of the problems, they require regular maintenance. Although most of the state agencies have started looking at drainage as a major component of the design, lack of maintenance and regular inspection often leads to inadequate performance of the drainage features which ultimately leads to the failure of the pavement structure. Several research studies have been conducted recommending procedures for regular inspection and maintenance of the drainage features.

Systematic inspection using appropriate performance indicators can give an estimate of the state of the drainage system. The most significant development in the field of inspecting subsurface drainage (particularly edgedrains) is the use of small diameter, optical tube video cameras. Iowa was one of the first states to effectively use video inspection (“Video Evaluation of Highway Drainage Systems,” Transportation Research Record 1329, TRB, National Research Council, Washington D.C, 1991, pp-27-35). The most common practices for maintenance of edgedrains are: flushing of the system, cleaning the outlets and replacing the outlets when damaged. Flushing and cleaning of outlets at regular intervals can ensure that the drainage system is never damaged beyond repair. However, surveys in the past have shown that most agencies do



Figure 2.13: Rodent in Subsurface Drain (Taken from “Making Edge Drains Work, Kuennen, Tom)

not follow a scheduled procedure for maintenance and inspection of the drainage features. Precipitates (e.g. chemical, silt and debris), clogging and mowing damage have been found to be the most prevalent problems associated with edgedrains. Several solutions to these problems have been suggested by researchers. Use of very open permeable-base-type material, with geo-textile filters placed around the outside of the drain is a commonly used to prevent clogging. Clogging is often associated with crushed outlet pipes and hence outlet pipes should be inspected and protected regularly. Headwalls should be built by the side of the edgedrain outlets to protect them from mowing damages. NCHRP Synthesis 285 recommends the following improvements in the design, construction and maintenance of highway edgedrains.

- Design Improvements:
 - The need to consider alternate designs for varying soil types
 - Establish better design details
 - Include maintainability in design criteria
 - Spend money on building high-quality edgedrains without taking shortcuts
- Construction Improvements:
 - Contractors and inspectors need to personally inspect the outlet pipe
 - Improve construction inspection such as the use of end-result video inspection
 - Document proper installation practices
 - Hold preconstruction meetings
 - Arrange training for contract administrators on requirements
- Maintenance Improvements
 - Improve maintenance access options for cleaning
 - Improve maintenance inspection
- Management Improvements
 - Establish a basic policy on edgedrain maintenance with strong administrative support

Another important reason for irregular inspection and maintenance of drainage features is the lack of funds with the state agencies. Inspection, in conjunction with preventive maintenance programs has proven to be many times more cost cost-effective (a \$3 to \$4 return on each \$1 invested) than detection and repair programs, as reviewed in **NCHRP synthesis 96 and NCHRP synthesis 223**. However, during a past survey, many agencies claimed that they did not have the \$1 to invest. Hence a combination of design and construction practices that will require minimum maintenance (maintenance free design is not practically possible) is sought by all the agencies.

Apart from recommendations on the maintenance of subsurface drainage features, researchers have also devised some standard recommendations on the drainage features on bridges that will minimize damage to the pavement/bridge structure due to improper drainage. Some of these key recommendations are listed below.

- The face of the slopes under the bridge should be covered with a geo-textile drainage fabric or sand layer to minimize the loss of soil due to erosion and seepage. Concrete revetments, if used, should also be placed on top of a geo-textile drainage layer to avoid internal erosion under the revetment

- A preformed permeable liner with a filter fabric face should be used behind the abutment and wing-walls to remove free water from approach structure to a system of drainage pipes
- A permeable base should be provided under the approach slab and adjoining pavement
- A set of perforated pipes should be installed to carry the water to collection points outside the abutment. Water from these pipes should not be allowed to drain onto unprotected slopes of the approach embankment

Geo-composite drainage system: New prefabricated drainage systems, called geo-composite drains, have been developed for drainage behind the abutment. These are made from various types and configurations of polymeric drainage cores covered by geo-textile filters that are bonded directly into the cores. The drainage system completely covers the backfilled side of the abutment with the geo-textile filter attached to the side of the core facing the backfilled soil. The solid portion of the drainage core supports the geo-textile and maintains an open volume for free movement of water.

Filters: In order to keep the drainage layer and piping system functional for a satisfactory period, clogging must be prevented. This can be achieved by using a filter between the drain and the adjacent material. Aggregate filters have been used for a long time and if properly constructed, will perform well. Grain-size distribution of a graded aggregate filter creates its pore structure that, in turn, controls the filtration performance. There are well established criteria for specifying the grain size distribution of aggregate filters. These criteria based on theoretical relations among particle size, pore size, and retention ability of granular materials have proved adequate through decades of use.

The use of geo-textiles in filter applications has become widespread in the past 20 years. They can be effective in protecting soil from erosion while permitting water to pass through the fabric to the drain. Geo-Textile filters have two advantages over aggregate filters: (a) they do not store a significant amount of water in the fabric layer and (b) there is more flexibility in the selection of the type and material properties desired.

2.5. Bridge Approach Repair Strategies:

This section describes about the different repair strategies adopted in case of already failed bridge approaches. Initially, the repair strategies adopted, concentrated mainly on the surface layer of the roads. Many agencies used asphalt resurfacing over an existing bridge approach as an inexpensive method for solving the bridge approach problems. However, these solutions did not last for long as the problem was originally a sub-surface problem and it subsequently propagated to the top layer in few years. The result was that agencies had to spend more time and money on repairing the approaches. This forced researchers to look for solutions that could fix the sub-surface problems instead of just masking them. Different states have adopted different methods to repair the sub-surface problems at bridge approaches. The most common among these methods are:

1. Slab Stabilization and Slab Jacking
2. Injected Polyurethane Slab Jacking or URETEK Method™
3. Complete Replacement of Bridge Approach

Slab Jacking and Slab Stabilization:

Slab jacking is considered for any condition that causes non-uniform slab support, such as embankment settlement, settlement of approach slabs, settlement over culverts or utility cuts, voids under the pavements, differences in elevation of adjacent pavements, joints in concrete pavements that are moving or expelling water or soil fines, and pavement slabs that rock or teeter under traffic. The purpose of slab jacking is to fix the above mentioned problems by injection of a grout under the slab. The grout fills voids under the slab and thereby restores uniform support. When necessary, slab jacking can also be used to raise the slab. Location of the injection holes must be determined, taking into consideration, the size or length of the pavement area to be raised, the elevation difference, subgrade and drainage conditions, location of joints or cracks and the manner in which the slabs will be tilted or raised. A variety of materials have been successfully used for slab jacking. These materials range from cement/fly ash grouts to expansive polyurethane foam. The polyurethane materials though more costly, are considered more durable and efficient in raising the slab. Pumping and jacking operations normally start at the lowest point in a depressed area and work outward in both directions. Grout is pumped into the holes drilled in the slab, by lowering an injection pipe connected to the discharge hose of the grout pump. The lifting should be done in increments of about 0.25 in. with frequent changes in injection locations to keep slab stresses at a minimum and avoid cracking. The rate of grout injection should be kept uniform and as low as possible. After slabjacking has been completed in a hole and the discharge pipe is removed, the hole should be plugged immediately. When slabjacking to the desired elevation has been accomplished, the temporary plugs are removed and the injection holes are filled with some kind of a permanent plug. It should be noted that the process of slab jacking requires specialized contractors. If not done properly, slab jacking can cause uneven slab support which results in slab cracking.

Pavement subsealing should be accomplished as soon as significant loss of support is detected. Subsealing is the process of stabilizing the pavement slab by the pressurized injection of a cement grout or polyurethane material through holes drilled in the slab. It is also called undersealing or slab stabilization. Unlike slabjacking, subsealing fills voids without raising the slab. In order to be effective, subsealing should be performed before the voids become so large that they cause pavement failure.

The first step in the process of subsealing is the detection of voids under the slab. In order to achieve a good degree of subsealing, accurate identification of the location and extent of subsurface voids is necessary. Out of several methods of void detection in use, probably the simplest one is visual inspection of the pavement to locate areas of distress. As already discussed in this chapter, the presence of ejected subgrade or base material, staining of pavement surfaces adjacent to joints, vertical movement at joints or cracks and faulting of joints are evidence of possible voids under the slab. The most common method of void detection is deflection testing. This is done by slowly driving a heavily loaded vehicle over a transverse joint while observing deflection of the slabs. Visual detection of deflection means the slab needs undersealing. The deflections can also be measured by devices equipped with sensitive dial gauges. Recently, the use of non destructive testing technology has been applied for void detection purposes. Technologies

like the Falling Weight Deflectometer and Ground Penetrating Radar have been recently used extensively to detect voids under slabs. Details of these methods have not been discussed in this report. However, extensive literature is available on the World Wide Web for this topic.

Another method used to fill minor voids under pavements caused by pumping action is asphalt undersealing. In this method, a liquid bituminous material is injected under pavements. Use of this method to fill voids greater than 1 inch or to raise slabs, is not recommended. Besides, this method is potentially dangerous as it involves operation of materials at very high temperatures. The method of placing bituminous undersealing is practically the same as that used for cement grout undersealing.

Injected Polyurethane Slab Jacking or the URETEK Method™

It has been observed that traditional slab repair methods like “mud jacking” can often lead to more problems in the future because of the fact that they inject more dirt and water under the slabs. Injection of Polyurethane foam is often considered to be a better alternative for repairing existing bridge approaches than conventional grouting or undersealing methods. One of the most commonly used methods of injecting polyurethane foam is called the URETEK Method™, which is a patented process that uses high density polyurethane foam (HDPF) to lift, realign, underseal and fill voids under concrete slabs. In this method, the polyurethane foam is injected through 5/8-inch holes drilled in the concrete slabs. This material is extremely dense and it solidifies as soon as it comes in contact with the atmosphere. The volume of the solidified material is up to 20 times its liquid volume and it provides a lifting force of approximately 8000 pounds per square foot. When fully cured, the foam has a compressive strength of 90 psi and tensile strength of 80 psi. It reaches 90% of its strength in 15 minutes and hence the repair process is completed quickly. In a case study, the Kansas Department of Transportation (KDOT) compared three undersealing products: a cementitious grout, an asphalt emulsion and a polyurethane material. For effective product evaluations, similar sections were chosen for field testing, all three products were installed and their performance was evaluated. The results for the cementitious grout and the asphalt emulsion were not favorable. Cores of the roadway taken after injecting the undersealing material showed only spotty evidence of the undersealing material for cement grouts as well as asphaltic emulsions. However, the patented URETEK 486 material was observed to be effective in penetrating even the smallest of voids. Trapped water also did not have any detrimental effect on the reaction of the URETEK foam (<http://www.uretekusa.com/resources/index.php>, accessed on 09/26/05). The URETEK process has been successfully used to level depressions on bridge approach slabs, continuously reinforced concrete pavement (CRCP), drainage structures and parking lots. It has also been used on jointed concrete pavements (JCP) to reduce longitudinal and transverse faulting, level depressions, slab undersealing and filling voids. In order to achieve better long term performance of the bridge approach slabs, instead of just stabilizing and raising the slab back into position, stabilization of the base/subgrade material should also be carried out. One of the most common methods for this purpose is the URETEK deep injection method.

The URETEK deep injection method strengthens the underlying foundation on which the road materials lie and hence the pavements/bridge approaches last longer and require less frequent maintenance. Figure 2.14 shows the different elements of a shifting/unstable/damaged underground base.

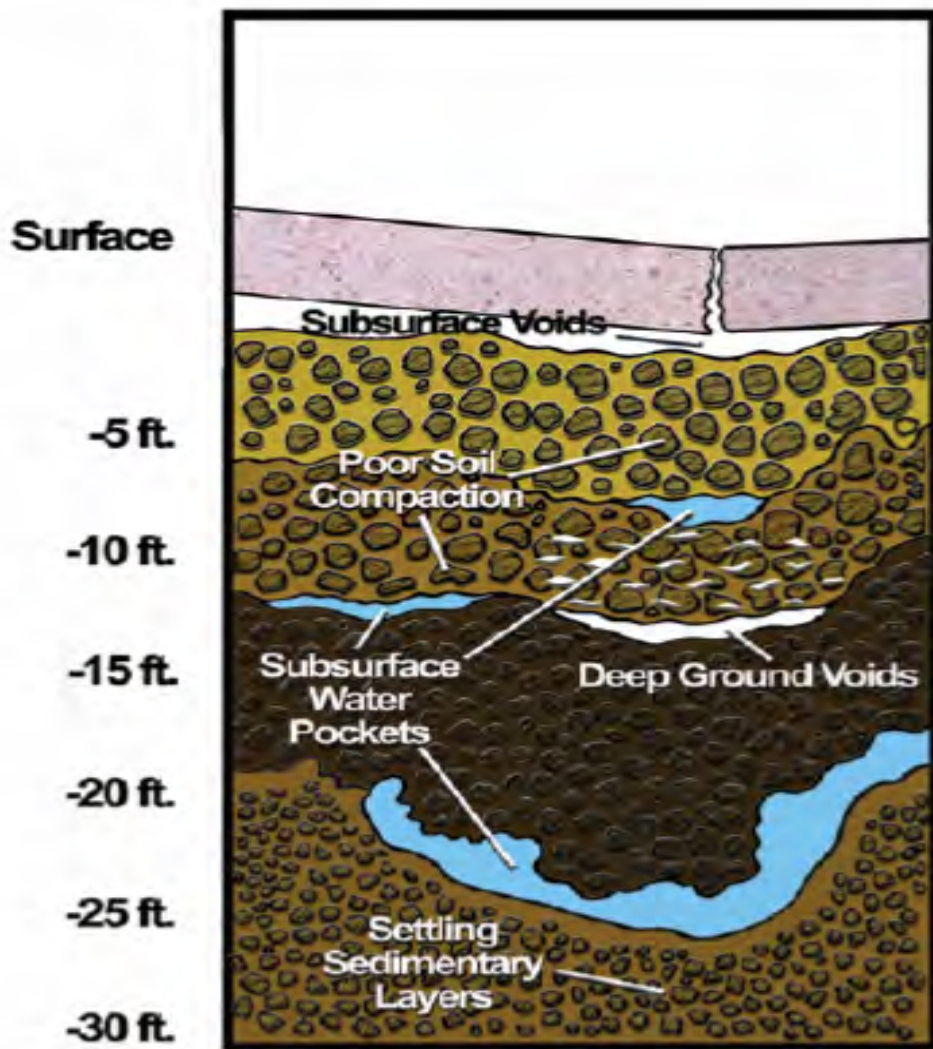

Figure 2.14: Subsurface Defects (from www.uretekusa.com)

The material used to stabilize an underground soil base must not only fill the voids, but also should seal them from the entry of water. The URETEK 486 material used in the deep injection process, fills, densifies and stabilizes low density compressible soils to depths of 30 feet and beyond. Figure 2.15 demonstrates the working of the URETEK deep injection process.

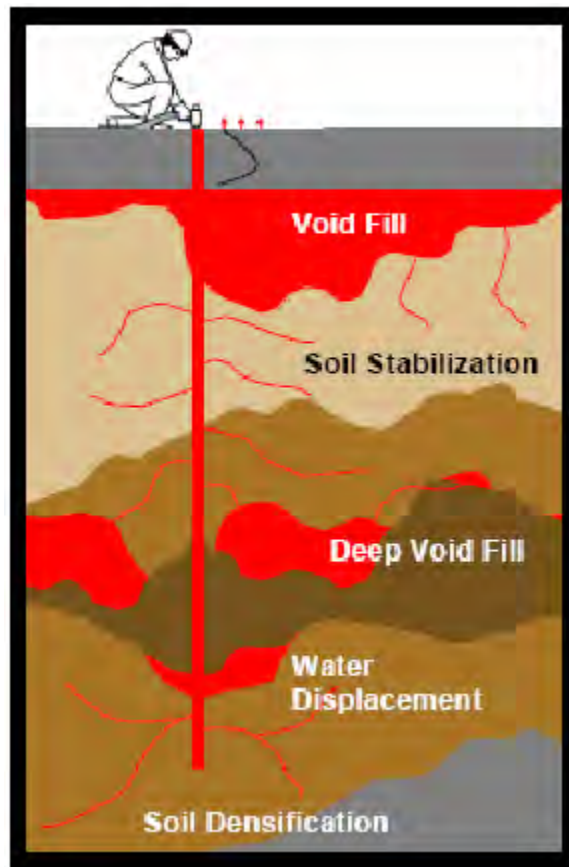

Figure 2.15: URETEK deep injection process (same source as above)

The main features of using the URETEK method that are considered to be advantageous over the conventional grouting and slab jacking methods are:

- a. **No Disruption:** The time available to conduct road maintenance work is one of the major concerns for transportation agencies as well as for road users. Because of high traffic volumes and longer rush hour traffic patterns, road maintenance works normally start late at night and last into early morning hours. The fact that the polyurethane foam solidifies as soon as it comes in contact with the atmospheric air, prevents disruption of traffic flow for long periods of time. This saves significant interruptions to business, operations, workflow and/or safety.
- b. **Low Cost:** The URETEK method is significantly less expensive as compared to complete replacement of the approach slabs. URETEK agency claims that the cost can be up to 75% less for URETEK.

- c. **Fast and Accurate:** URETEK foam injection has been observed to be more accurate in controlling the level up to which the slab is to be raised. Accuracies of 1/10' of an inch have been achieved in previous works.
- d. **Quiet and Safe:** The foam injection method generates less noise than other slab repair techniques. Also, the polyurethane foam being environmentally friendly, pollution of the environment or surrounding ground water is not a risk.

Full Depth Repair

Full depth repair of slabs becomes necessary when normal maintenance procedures can no longer correct the effects of ordinary pavement wear or use. In case of a full depth repair, the existing section of deteriorated and loose concrete is removed. Then the base course is examined, all disturbed material is removed and the patch area is compacted. Sometimes the granular base material is difficult to compact and if the new slab is placed without proper compaction of the base course, settlement of the slab may occur. In such a case, replacing some or all of the disturbed base material with concrete or flow able fill may be the best alternative. If excess moisture is observed upon removing the existing deteriorated slab, that portion of the base material should be removed or dried before placement of the new slab. After pouring the concrete at the spot of patching, the transverse and longitudinal joints in the repair area must be sawed when the concrete is green, to control cracking. If the concrete cracks before initial sawing, then the resulting cracks must be prepared and sealed properly.

Complete Replacement of the Bridge Approach

If the bridge approach fails beyond repair, the only alternative is to remove the existing approach slab and construct a new one. If the bridge-approach shows repetitive distresses and requires repair work too frequently, this may indicate that the problem lies in the base/subgrade material and not in the approach slab. In such a situation, the existing slab needs to be removed and a new slab constructed in its place. However, before placing the new slab, steps should be taken to improve the condition of the base material. This may involve installation of edge drains, installation of geotextiles to prevent migration of fines, installation of horizontal drainage layers or stabilization of the base material. However, it should be noted that complete replacement of the bridge approach is a significantly expensive alternative and should be considered only when the bridge approach has failed beyond repair, or when the cost of frequent maintenance demands a new approach. This alternative is usually time consuming and involves long term interruption of traffic flow.

(This page intentionally left blank)

CHAPTER 3

SURVEY OF TXDOT DISTRICTS

3.1 Survey Procedure

The first step in the research study was to conduct a survey of the general population of TxDOT bridges to determine the major factors contributing to the problem of water intrusion. The researchers contacted the Director of Maintenance, Director of Construction, or other appropriate personnel in all 25 TxDOT districts and received survey responses from 24 districts. The survey focused on determining the extent of water intrusion and approach slab settlement problems at bridge ends, and maintenance methods or drainage designs used in each district to fix the problems. The survey questions and responses are presented in Appendix B. Generally, these are the questions asked: (a) what are the extent and causes of water intrusion and settlement observed in your district; (b) what surface drainage and sub-surface drainage systems are used to prevent water intrusion at bridge ends in your district; and (c) what approach slab details are employed in your district and what repair techniques have been used. Researchers also used the survey to identify any specific bridges that might be used for further investigation and identify additional TxDOT personnel to contact for insight into water intrusion problems. The research team accomplished the survey by first transmitting the questions to the appropriate TxDOT engineer and then collecting the information by telephone or personal conversations. In some cases the respondents returned the completed questionnaire. Responses to the survey are summarized in the following paragraphs.

3.2 Overview of Findings

3.2.1. Extent of Water Intrusion and Approach Slab Settlement Problems at Bridge Ends

Water intrusion and approach slab settlement problems vary greatly across the state of Texas. While some districts such as Amarillo, Austin, Brownwood and Odessa report that water intrusion and approach slab settlement are not commonly observed problems, other districts such as Beaumont, Corpus Christi, Fort Worth, Houston and Lufkin view both water intrusion and approach slab settlement as significant problems. Some districts such as the Dallas district report that settlement at bridge ends is a problem on older bridges that do not have approach slabs, while others such as the Houston district report that older embankment designs have fewer problems because of better drainage systems that were once used. Several districts do not use approach slabs in their bridge designs. Many of the engineers contacted attribute water intrusion and approach slab settlement problems to poor construction practices and lack of proper inspection during the placement of fill material near the abutment walls. Due to a lack of adequate compaction, void areas form near abutment and retaining walls leading to the collection of water and loss of fill material. Several years ago, the Yoakum district initiated the use of hand compaction of material near abutment walls during construction and they have observed no water intrusion problems at those bridge ends.

Many of the respondents reported major problems of water intrusion and loss of material beneath riprap. The loss of material beneath the riprap creates large void spaces under the concrete slabs. The void spaces are not easily detected from the surface and can lead to catastrophic failures. In one incident, a post hole dug during the installation of a guard rail in Fort Worth created a pathway for water intrusion. Material used as fill around the post was not properly compacted and water entered the hole and created a void approximately one-quarter mile in length beneath the pavement.

The majority of the respondents believe that the water intrusion comes from surface water as opposed to wicking action from beneath the approach slabs. Water intrusion from surface water results from poor drainage systems, deterioration of joint sealants and water flowing onto embankments. Several TxDOT engineers described erosion of riprap fill material when streams overflowed their streambed and got beneath the riprap or from wave action at lakes. The Atlanta district uses 10-in diameter rock with a six-in bed for riprap near streams and pumps grout into voids between the rocks. Personnel from the Austin, Bryan, Houston, San Angelo, and Tyler districts have observed water in areas where wicking action is suspected, but wicking is not considered a common occurrence. The Abilene district has one location near a bridge end that seeps water continuously and became a subject of further study within this research project.

3.2.2 Surface Drainage and Subsurface Drainage Systems Used to Prevent Water Intrusion

Most districts report having no specific surface drainage system designs. A number of districts report using the TxDOT standard drainage systems. In some cases, curbs and gutters are used to move the water from the bridge deck down the slopes of the embankment, or to channel the water off the bridge deck through side drains. However, new designs for Thrie-beam guard rails require support systems that block the surface water pathways and create problems in moving the water through drainage systems. Many districts use concrete flumes with basins to collect the water from the bridge deck and move the water down the embankment slope. A common problem is collection basins that are too small in diameter or depth for large flows during heavy rains. The excess water spills over the collection basin and sometimes over the concrete flume to flow directly onto the embankment material. Joints between the basin, flume and embankment are particularly susceptible to water intrusion. Several surface drainage systems used by individual districts are given in Appendix C.

Only a few TxDOT districts reported ever using a subsurface drainage system. The Houston district reported that in the past, subsurface drainage systems were used and problems with water intrusion and approach slab settlement increased when the subsurface drainage systems were no longer used. The Fort Worth district described a subsurface drainage system that incorporated a filter material. However, after six months of use the filter paper became clogged and the system was unsuccessful. Details of sub-surface drainage systems found in this study are also given in Appendix C.

3.2.3 Approach Slab Details and Repair Techniques used by TxDOT Districts

All but a few TxDOT districts use approach slabs at bridge ends. Some districts have a mixture of bridges with or without approach slabs. There does not appear to be a direct correlation between the use of an approach slab, or lack of an approach slab, and water intrusion or bridge end settlement problems. The Austin district has constructed bridges with approach slabs and without approach slabs and has observed settlement in both types. They attribute the settlement to poorly consolidated fill material and loss of material due to water intrusion. On the other hand, the Corpus Christi district does not use approach slabs and thinks that approach slabs ease settlement problems. The key issue seems to be the entrance of water through joints between the pavement and the bridge end, and the fewer the joints or the better the joint sealing, the less susceptible the bridge end is to water intrusion and subsequent settlement problems. The Childress district experienced water intrusion problems through joints at the wing walls and, since the mid 1990's, have constructed approach slabs to extend over the wing walls and thus eliminate the joint.

A wide range of repair techniques are used within the various TxDOT districts. For minor approach slab settlement problems, most districts use hot-mix asphalt to "level-up" or "smooth-out" the height differences of the approach slab and abutment wall or pavement surface. The repair is considered a temporary fix, and must be repeated when necessary. A similar technique is to apply an overlay pavement, but this method can create bridge rail height issues.

Several districts have accomplished repairs by removing the approach slabs along with material below the approach slabs and replacing the material with cement-stabilized fill. Such repairs are costly, but have proven effective. Some districts have added asphalt stabilized base to the repairs as fill material. The Dallas district recommends replacing poor native soils with select material to a depth of three feet. The El Paso district successfully used a cement slurry beneath an approach slab on a frontage road, but the repair required closing the roadway for three days.

Mudjacking is a technique that has not proven practical or reliable. Mudjacking is a multistage operation and fluid pressures can "blow out" riprap. Often the mudjacking operation must be repeated soon after the repair.

A very successful repair technique is the injection of polyurethane foam beneath the slab or pavement surface which can actually raise the slab or pavement surface and can be carefully controlled for leveling operations. At least 13 TxDOT districts have used a proprietary method named URETEK® in approach slab and riprap repair. Although the technique is considered to be expensive, it works well and can be accomplished, in most cases, in short duration repair times. A specification for using the repair was written by the Lufkin district and is given in Appendix C.

(This page intentionally left blank)

CHAPTER 4

DETAILED STUDY OF SELECTED BRIDGES

4.1 Visits to TxDOT Districts

Researchers visited field sites in the Abilene, Lufkin, Lubbock and Houston districts. Because of special problems associated with the Abilene site, a subsurface investigation was conducted on a portion of the US Highway 83 overpass over Antilley Road. A description of the findings and observations from the site visits and field investigation is presented in this chapter.

4.2 Abilene District – US Highway 83 Overpass at Antilley Road

4.2.1 Introduction

Based on discussions with Paul Hoelscher, Director of Construction (DOC) in the Abilene (ABL) district and Project Director (PD) for this research project, it was decided that the US Highway 83 Bridge over Antilley Road would be a good candidate for further study as part of this project.

Paul and other TxDOT personnel from the ABL district and Abilene Area Office (AO) indicated that they have experienced a continual problem with apparent subsurface seepage flowing through and onto a section of asphaltic concrete pavement (ACP). The seepage area is located approximately 900 feet south of the southern concrete bridge approach slab (BAS) within the southbound lanes at the subject bridge. Paul further indicated that the seepage area remains wet throughout the year irrespective of season or weather conditions.

Opinions vary among TxDOT personnel regarding the source or cause (mechanism) of the seepage. Some believe water is being “wicked up” laterally from the adjacent Kirby Lake or from the resultant water table below the embankment fill soils underlying the pavement section. Others believe the seepage is being caused by surface water infiltration through cracks and joints in the ACP, through the pavement itself and through water that stands in the depressions created by the milled rumble strips along both sides of the pavement. Others also believe it may be a combination of these mechanisms.

For these reasons, it was decided that the researchers would conduct a “limited” subsurface investigation to determine the source and cause (mechanism) of the seepage, and to provide TxDOT personnel with guidance and recommendations for mitigation of the seepage problem.

4.2.2 Site Description

The subject bridge is located in the southern portion of the city of Abilene (Taylor County) approximately one mile south of a highway interchange with Loop 322, US Highway 83/84 and Business Route 83D.

Kirby Lake is located east and in close proximity to the Antilley Road Bridge. The western shoreline of the lake is sited along the eastern side of the northbound access road on the east side of the bridge. It appears that the lake covers an area of about 575 acres based on calculations obtained from scaled dimensions on a city map. Based on an elevation survey conducted by Chad Carter with the Abilene AO, the Kirby Lake water level was found to be approximately 30 feet below the Antilley Road bridge deck. Assuming a project elevation datum of 100.0 feet on top of the bridge deck, we will assume a lake water surface level elevation of 70.0 feet for the purposes of this study. A Site Plan has been provided as Figure 4a which shows the location of the subject bridge, Kirby Lake, the seepage area, and the exploratory borings drilled for this study.

The bridge structure is comprised of cast-in-place (CIP) reinforced concrete and prestressed precast concrete elements supported on a drilled shaft foundation system. Concrete bridge approach slabs (BAS's) have been constructed at the bridge ends which span 20 feet. The bridge approach pavements are flexible and consist of an asphalt concrete (AC) surface layer. Additional detail regarding the flexible pavement designs is provided in Section 4.2.3, "Pavement History at the Site."

The subject bridge is constructed on a "man-made" embankment fill or "header bank" to provide a grade separation between US Highway 83 and Antilley Road below. The bridge was constructed with two 12-foot lanes and wide shoulders on each side of a concrete Jersey barrier separating northbound and southbound traffic. Two-lane access roads have been constructed along both sides of the bridge. An exit ramp was constructed for southbound traffic about 4 years ago as described in Section 4.2.3 below. This exit is located very close to the bridge end between the south end of the BAS and the subject seepage area.

The fill embankment extends to a height of approximately 32 feet above the surrounding original grade at its highest point. The embankment soils on the eastern side of the bridge (adjacent to Kirby Lake) are supported by a mechanically stabilized earth (MSE) retaining wall. It is assumed (not verified) that some type of imported predominantly granular soil material was used in the reinforcement zone behind the precast panels of this MSE wall. The lateral extent of the assumed granular material is unknown at this time. If this is the case, there must be an interface between the granular materials on the east side of the bridge and the silty clay fill materials found in the borings on the west side of the bridge. If the granular fill materials exist as expected, it is probably safe to assume that these soils would be well drained, allowing for free flow of water that might infiltrate below the pavement surface level.

The western side of the bridge embankment was constructed with a fill slope. It appears that the finish slope inclination is on the order of 2:1 (horizontal to vertical). It may be significant to note that the original profile of the fill embankment was likely altered when a new exit ramp was added along the western side of the embankment south of the bridge about four years ago. Based on the soil materials encountered in the exploratory borings for this study, it appears that the embankment fill outside the limits of the MSE wall consists of a predominantly reddish-brown silty clay material with varying amounts of silt, sand and gravel.

During one of our field reconnaissance trips to the site, we observed a CIP concrete double-box culvert on the south side of the bridge. The culvert is approximately 16 feet wide and 4 feet high with concrete headwalls that daylight on both sides (east and west) of the embankment. The culvert is aligned transverse to the centerline of the roadway (US 83), and is located within the “study zone” (between the BAS and seepage area). Approximately 8 inches of water was found standing in the culvert and outside the headwalls at the time of our site reconnaissance.

Field measurements and differential leveling performed by the research team indicate that the centerline of the culvert is located about 25 feet north of Boring 3 (which is located in the seepage zone). This would translate to a dimension of about 17 feet from the southern side of the culvert to Boring 3. Elevation information shows the top of the culvert and the flow line to be approximately 6 feet and 10 feet, respectively below the pavement surface at Boring 3 (which is at Elevation 79.9).

Assuming the lake water level information is correct, the pavement surface (in the seepage area) at Boring 3 is about 10 feet above the lake level. Dependent upon the accuracy of the survey data, the elevation of the base slab and the standing water level in the culvert (8” deep) is roughly coincident with the Kirby Lake water surface.

Based on a conversation with Chad Carter from the Abilene AO, it is likely that the culvert was constructed before the embankment fill was placed, as opposed to using open-cut methods to construct the culvert after the embankment was built. The actual construction method used to construct the culvert has not been verified at this point.

The pavement surface on the south side of the bridge appears to slope from east (at the MSE wall) to west (based on visual observation only). David Seago (former Abilene AE) who was involved in the design and construction of several road projects in this area recalled the high point (crown) of the pavement to occur along the centerline between the southbound and northbound lanes (beneath the concrete Jersey barrier). It would be beneficial to the project to obtain an as-built topographic map of the subject bridge to verify the site conditions.

4.2.3 Pavement History at the Site

Based on discussions with various ABL district personnel as well as with others from the engineering and maintenance side of the Abilene AO, it is our understanding that approximately 900 feet of ACP was replaced in both southbound lanes of the study area about 4 years ago. The pavement was apparently replaced as part of a project that provided an exit ramp to the western access road for southbound traffic on US 83. The bridge approach pavement was apparently reconstructed to remediate base failures and extensive pavement distress due to saturated base and subgrade soils resulting from the subsurface water (seepage) problems.

It is our understanding that the original pavement section consisted of 2 to 3 inches of asphalt concrete (AC) over 14 inches of flexible base material over the compacted embankment fill

(subgrade) soils. Based on a conversation with David Seago, former Abilene Area Engineer (AE), the existing pavement materials were removed to a depth of approximately 14 inches below the original pavement surface. The upper 6 inches of soil materials in the base of the excavation was then treated (mixed-in-place) with cement. It is not clear if the treated materials consisted of a combination of flex base and embankment fill materials, or just the salvage flex base alone. Upon completion of the cement treatment process, 12 inches of asphalt stabilized base (ASB) was installed followed by a 2-inch lift of Type C hot mix asphalt concrete as the final wearing surface.

Abilene maintenance section personnel indicated that a significant flow (quantity) of water was observed to be draining out of the exposed flex base cut faces after the inside lane was excavated out prior to cement treatment and paving operations. One individual described the flow as a “small river” running down the hill to the low point of the excavation. I was unable to ascertain any information regarding the amount of time it took for the water to drain out of the base after the excavation was opened up. One would presume that the flow would eventually “slow” to a manageable level permitting construction of the new pavement section.

Based on a visual examination of the pavement, it is clear that at least one seal coat layer has been installed over the “deep-lift” ACP. The seal coat begins at the end of the concrete BAS and ends in the subject seepage area approximately 900 feet south of the BAS.

4.2.4 Site Reconnaissance

The researchers visited the site on four separate occasions in advance of drilling operations. The purpose of these visits was to:

- Perform a visual reconnaissance of the site and surrounding area
- Observe the subject seepage area to determine possible causes or sources of subsurface water infiltration
- Look for possible sources or access points for surface water infiltration
- Layout the boring locations
- Meet with city of Abilene personnel to obtain underground utility clearance prior to drilling
- Document the site and seepage area conditions using digital photography
- Perform visual inspections of the bridge structure and associated appurtenances
- Perform visual inspections of existing pavements for any distress, cracking or open joints
- Perform differential leveling for the purpose of obtaining key elevation data relative to the Antilley Road bridge deck (assumed project datum elevation of 100.0 feet)

4.2.5 Pavement Condition and Seepage Area Observations

The concrete bridge approach slab (BAS) on the south (departure) side of the bridge within the southbound lanes was found to be in very good condition without any significant cracking. In contrast, the BAS on the south (approach) side of the bridge within the northbound lanes was found to be in fair to poor condition with several cracks that had been patched with a hot pour asphaltic material.

The pavement was observed to be in good condition in the “study area” where a seal coat had been applied over the “deep-lift” AC section (the 900 foot section between the BAS and seepage area). The pavement in the southbound lanes south of the seepage area exhibited severe distress in isolated areas. The distress consists predominantly of alligator cracking in the wheel paths which appears to be indicative of base failure.

The ACP in the northbound lanes (south of the bridge) was found to be in much worse condition within the corresponding study area on the east side of the bridge. Extensive cracking of the pavement was observed along with some rutting and alligator cracking in the wheel paths and some minor shoving.

It should be noted that cracks in flexible pavements are often not visible during the warmer times of the year; however, in cases where cracking exists, these cracks have a tendency to open up and become more visible during the cooler times of the year. In many cases microcracking may be present in the pavement surface and not be detectable by the naked eye. Some studies have shown that significant quantities of surface water may infiltrate through the pavement itself into the underlying base and subgrade materials below even though open joints or cracks may not be detectable by visual examination.

Digital photographs and video have been taken during most of the trips to the site before, during and after the field investigation (when traveling through the Abilene area). The purpose of this task was to document any variations that might be occurring with regard to the real extent and rate of seepage as they relate to changing seasons and climatic conditions.

Observations of the seepage area during the site reconnaissance and drilling phases of this study (July 2005) indicated moderate seepage emanating out of a portion of the inside (westernmost) lane and the shoulder with moderate wetting of the adjacent soils at the pavement edge.

Two other visits were made to the site on August 11, 2005 and October 7, 2005 as one of the researchers passed through the Abilene area. It should be noted that recent rains had occurred prior to both of these visits. Precipitation data could be obtained around the time period of the visits to get a better idea as to the intensity, duration and quantity of rain at the site. It should also be noted that the first significant “cold spell” occurred the day and night before the final visit with low temperatures in the forties (degrees Fahrenheit).

The seepage observed during these latter visits was much heavier than had been seen during July 2005. The extent of the seepage zone had increased significantly to include larger

portions of the inside lane and shoulder. Seepage was also seen to be present along the pavement joint between the inside and outside lanes. Seepage quantities were also clearly heavier than observed in July 2005.

Based on these observations, it is clear that surface water (rain) significantly increased the quantity of seepage as well as the affected pavement area (wetted surface area). It appears that the seepage is coming up through the pavement in the seepage area through cracks and pavement joints in the inside lane and shoulder area as well as between the joint between the inside and outside lanes.

It should also be noted that cracking in the pavements seemed to be more pronounced and noticeable (the cracks appeared to be wider and more prevalent) during this last trip to the site, presumably due to the colder temperatures at the time of the visit.

4.2.6 Field Investigation

Three exploratory borings were drilled at the site on July 18, 2005 by the TxDOT drilling crew. Original plans by the research team included drilling up to five borings in the study area; however, the drilling crew advised us on the day of drilling that they would only be available for one afternoon of drilling.

Based on this information, the research team elected to drill three borings in the inside (westernmost) southbound lane in the study area south of the bridge between the BAS and the seepage area. The approximate location of the exploratory borings is shown on the attached Site Plan (Figure 4a).

The first boring (B-1) was drilled to a depth of 38.5 feet and is located approximately 5 feet south of the BAS at the highest point on the embankment. The third boring identified as B-3 was drilled in the seepage area which is located approximately 900 feet south of the BAS. Boring B-3 was drilled to a depth of 18.5 feet. Boring B-2 was positioned about half way between Borings B-1 and B-3 and was drilled to a depth of 25.0 feet. The elevation of the pavement surface at Borings B-1 through B-3 respectively was found to be at 100.1, 92.3 and 79.9 feet (relative to the assumed bridge deck project datum of 100.0 feet).

The borings were drilled using a Failing rotary wash drilling rig using bentonite slurry as the drilling fluid. After drilling to predetermined depths, galvanized steel Shelby tubes were pushed into the soil for the purpose of collecting undisturbed soil samples. The samples were extruded from the Shelby tubes at the site using a hydraulic sample extruder on the drilling rig. Soil samples were wrapped in aluminum foil and plastic wrap to preserve the moisture content of the samples. The samples were then stored in cardboard core boxes for transport to our laboratory facilities.

The samples obtained were normally 2 feet long. Exceptions to this occurred where the Shelby tubes were pushed to refusal, or where the soils were very weak, saturated or predominantly granular. It should be noted that the use of rotary wash drilling methods with Shelby tube samplers did not permit the sampling of the pavement section materials

(asphaltic concrete and flexible base), and did not allow measurement of groundwater levels at the site.

4.2.7 Laboratory Testing of Samples

After transporting to the Texas Tech Geotechnical laboratory, moisture content and field density tests were conducted on the samples. Moisture contents of the samples were determined by following the TxDOT test procedure Tex-103-E (ASTM 2216). Three tests for moisture content were performed for each sample. The moisture content at that particular depth was determined by the average value of the three observations. Field density of the samples was measured by cutting small cylindrical sections with a Miter Box and determining their densities. The tables showing observations for the moisture content as well as the field density tests have been attached in APPENDIX D. The degree of saturation values were determined by assuming a specific gravity of 2.67. The moisture content profiles for the individual boreholes were plotted and are also given in APPENDIX D. It should be noted that the sample depths in the plots have been represented in terms of elevation. The elevations were determined by allowing that the bridge deck had an elevation value of 100 ft. For example, the surface of the lake water which is at a depth of 30 ft from the bridge deck can be said to have an elevation of 70 ft. The following tables summarize the average moisture content at each sample depth.

Table 4.1 Moisture Content Variation with Depth for Bore Hole 1

Depth (ft)	Elevation (ft)	Moisture Content (%)
6	94.12	15.98
11	89.12	15.97
16	84.12	14.09
22	78.12	13.83
27	73.12	12.19
27	73.12	22.5
32	68.12	22.67
38	62.12	14.25

Table 4.2 Moisture Content Variation with Depth for Bore Hole 2

Depth (ft)	Elevation (ft)	Moisture Content (%)
3.5	88.78	15.89
6	86.28	11.43
9	83.28	12.97
11	81.28	11.59
14	78.28	14.24
19	73.28	11
24	68.28	16.2

Table 4.3 Moisture Content Variation with Depth for Bore Hole

Depth (ft)	Elevation (ft)	Moisture Content (%)
4	75.93	20.5
6	73.93	14.98
9	70.93	18.49
11	68.93	25.68
14	65.93	18.9
16	63.93	17.52
18	61.93	21.11

Field densities were measured from cylindrical samples cut from the bigger samples and the densities values were determined by measuring the volume of those cylindrical samples. Degree of saturation was determined from the field density value by using a specific gravity of 2.67. Tables listing the measurements for field density determination are given in APPENDIX D. The tables below summarize the degree of saturation at the sampling points.

Table 4.4 Field Density and Degree of Saturation Measurement for Borehole 1

Sample Depth	Moisture Content	Field Density (pcf)	Degree of Saturation
5'-7'	15.98	137.62	1.00
10'-12'	14.09	134.1	0.99
15'-16'	13.83	138.02	0.98
21'-23'	12.19	137.8	0.91
26'-28'	22	119.41	1.00
31'-32'	22.67	NA	NA
37'-38.5'	14.25	138.76	0.99

Table 4.5 Field Density and Degree of Saturation Measurement for Borehole 2

Sample Depth	Moisture Content	Field Density (pcf)	Degree of Saturation
2.5'-4.5'	15.89	134.16	1.00
5'-7'	11.43	132.74	0.87
8'-9.5'	12.97	138.39	0.94
10'-12'	11.59	135.22	0.88
13'-14.5'	14.24	132.22	0.99
18'-20'	11	132.96	0.85

Table 4.6 Field Density and Degree of Saturation Measurement for Borehole 3

Sample Depth	Moisture Content	Field Density (pcf)	Degree of Saturation
3'-5'	20.5	NA	NA
5'-7'	14.98	126.60	1.00
8'-9.5'	18.49	141.09	1.00
10'-12'	25.68	123.07	1.00
13'-15'	18.9	131.54	1.00
15'-17'	17.52	132.66	1.00
17'-18.5'	21.11	132.03	1.00

4.2.8 Data Interpretation and Proposing a Possible Mechanism

It can be seen from the plots of moisture content profile in Figure 4.6, that the moisture content does not show any particular trend with depth. In other words, the moisture content does not increase or decrease continuously with depth. Therefore, no particular theory about the source of water intrusion (whether the water is getting in from the top or is being wicked up from below) can be proposed based on the moisture content profile only. From the degree of saturation data, it can be seen that almost all the samples were nearly 100 % saturated. This means, the soil at the site does not have the capacity to hold any more water. It can be seen from the laboratory data that the average moisture content of the top layers near the bridge is less than that near the point of seepage. This eliminates the argument that if water is getting in through some joints/cracks near the bridge, the moisture content should show a decrease with distance away from the bridge. The researchers tend to believe that both mechanisms, water filtered in from the top and wicked up from bottom, are active at the site

under consideration. High moisture content near the surface can be attributed to the water getting in from top. On the other hand, wicking mechanism may be responsible for the high moisture content near the ground water table. However, the source of water seeping out of the pavement is the water getting into the subsoil through the pavement. Even though it is possible for water to be wicked up due to capillary action, it is not possible for water to be seeping out, if capillarity was the mechanism involved. The soil pores working as capillary tubes, will wick water up from the ground water table, but can not release the water by themselves. Release of water from the capillary pores is possible only if some kind of squeezing of the soil takes place. The researchers do not think, that is the mechanism involved in the seepage at the site. The theory that the water is coming through lateral seepage from the lake to the east side of the bridge can be discarded by the simple fact that the water is seeping out in the south bound lane (farther from the lake) whereas the north bound lane does not show any signs of water intrusion. The researchers believe that the water is surface water getting in through the joints/cracks existing in the bridge approach structure/pavement. Although no particular joint/crack was recognized to be the primary source of water intrusion, it is possible that the water accumulates after seeping in at different points. At the site, it was seen that there is a seal coat layer that continues from the bridge end up to a point just north of the point where water is coming out. One possibility is, the water may be flowing laterally just below the seal coat layer and is coming out of the pavement when the seal coat layer ends, i.e. it can be said that the seal coat layer may be working as a lateral drainage layer. The fact that the soil is saturated at almost all the depths can be used to support the theory of water flowing laterally just beneath the pavement. As the soil is saturated, it can not hold any more water. This means the water that gets into the subsoil through cracks/joints in the surface layer, does not have any way of going down the native soil. This may lead to the water flowing laterally if any preferred drainage path is available and coming out at a point where the lateral drainage path ends. The theory that the water is getting in from the top can be corroborated from the fact that the amount of water seeping out at the spot increases significantly after rainfall events. The researchers visited to site on two occasions when a major rainfall event had occurred the day before. On both the occasions, the seepage was seen to have increased significantly. The phenomenon of increased seepage after rainfall can not be explained if the water was being wicked up from below. One explanation behind why there is no water coming out in the north bound lane can be the slope of the roadway from east to west. So it is possible that all the water that gets into the pavement through the north bound lanes, flows laterally under the concrete barrier, to the south bound lane. The water may be coming out at a point where it finds a potential outlet.

It can be said that the laboratory testing and inspection of the site led the researchers to believe that the water is getting into the subsoil through joints/cracks already existing in the pavement/bridge approach. Joint repair and joint sealing should be carried out to seal the potential locations for water intrusion.

4.3 Lubbock District

The survey response from the Lubbock district indicated that although they do not experience many problems with water intrusion associated with approach slabs, they have noted problems with water intrusion in riprap and washing out of material at the toe of the riprap. Loss of material beneath the riprap causes large voids to develop beneath concrete slabs and can create differential settlement of the slabs along with concerns for collapse of the slab. The IH 27 overpass over 4th Street in Lubbock is an example of the problem. Figures 4.1 and 4.2 show washed-out fine material at the toe of the embankment. Water is able to enter through damaged or poorly sealed joints between the concrete slabs (Figure 4.3) and wash out fines in the embankment fill. Differential settlement of the slabs is evidenced in Figure 4.4.



Figure 4.1 Side View of Riprap with Washed-Out Fines at Toe



Figure 4.2 Top View of Riprap with Washed-Out Fines at Toe



Figure 4.3 Damaged Joint in Riprap Slab



Figure 4.4 Differential Settlement of Riprap Slab (Side View)

The Lubbock District now places filter fabric beneath joints in the riprap slabs to prevent the loss of fines as shown in Figure 4.5. Filter fabric is also placed near any point that might become a location for loss of fine materials (Figure 4.6). Details for the use of the filter fabric are provided in Appendix (Filter Fabric).



Figure 4.5 Filter Fabric at Joint in Riprap Slab during Construction



Figure 4.6 Filter Fabric at Drain in Riprap Slab during Construction

4.4 Lufkin District

Field visits to nine bridge sites in the Lufkin district were conducted by researchers on October 26-27, 2004. Mr. Paul Montgomery, Director of Maintenance (DOM) for the Lufkin (LFK) district, was responsible for identifying and selecting the subject bridges for field visits and as potential candidates for implementation subsequent to this research study.

Prior to conducting the field component of this trip, we met in the district office and were given a general overview of the Lufkin district's (LFK) bridge design approach, construction methods, soil and foundation conditions, climate, surface water and subsurface water conditions, bridge bump problems in the district, remediation methods used to correct the problem, and maintenance techniques employed to manage bridge bump problems. Upon completion of the briefing, we went into the field for a reconnaissance of the selected bridge sites.

Bridge #1 - US Highway 59 North at Loop 287

This location consists of two separate three-lane concrete bridges for northbound and southbound traffic over Loop 287. This bridge site is located in the northeastern part of the city of Lufkin (Angelina County). Most of our observations were made on the western bridge which carries the southbound traffic. The middle and outside (left) lanes of these bridges are for through traffic, while the inside (right) lane is for exit maneuvering.

Paul indicated that this is the worst bridge location they have in the LFK district in terms of the bridge bump problem. Both bridges have 12-inch thick reinforced concrete bridge approach slabs (BAS's) on the approach and departure sides of each bridge. The pavement section on either side of the BAS's consists of approximately 6 inches of asphaltic concrete pavement (ACP) over 12 to 15 inches of flexible base material. Paul pointed out that bridge bump problem along with any associated pavement distress is usually more pronounced on the approach side of a bridge as compared to the departure side.

This was certainly evident on the approach side of the BAS of the western bridge. Extensive map cracking was observed in the middle and outside (left) lanes of the concrete BAS with the distress being more severe in the middle section. The right side of this BAS had been replaced in September 2004 and looked in good condition. Paul indicated that they had cut that section out and removed the damaged slab by breaking it up with jackhammers.

The base material and subgrade soil beneath the damaged BAS were apparently saturated and standing water was observed on top of the base materials when the slab was removed. Paul also indicated that he observed a very large void beneath the middle portion (middle lane) of the BAS when this repair was done. This void was not filled during the repair of the inside (right) lane, however, Paul was anticipating repairing the middle lane in the near future. Three feet of existing soil materials were removed and replaced with cement-stabilized backfill. Paul indicated that he had taken some photos of this repair event.

It was evident that many attempts had been made at patching and smoothing the transition of a bridge bump at both the approach and departure ends of the western bridge (where the concrete BAS transitions to ACP). The surface of the patched areas was very rough at some locations.

We also observed that the majority of the concrete pavement joints around the perimeter of the BAS and cracks within the slab had not been sealed which could allow the transmission of surface water beneath the pavement into the underlying base or subgrade soils.

An obstruction to surface water drainage flow and discharge away from the bridge abutments and BAS's was created when a monocurb and thriebeam guard rail system was retrofitted (added) at the end of the concrete bridge rails. This was done to conform to a safety concern brought out by an NCHRP study to evaluate the safety and effectiveness of various bridge rail systems. In this instance, the contractor apparently installed the monocurb across the drainage collection point at the top of the shoulder drains, essentially cutting off surface water flow to the shoulder drains.

We also observed the abutment wall, wing walls and shoulder drains below and to the side of the bridge deck and BAS. Significant deposits of soil materials were observed on top of the footing of one of the abutments. It was not clear where these soil materials had come from, however, they conceivably could have fallen down through the joint between the bridge deck and BAS. Alternatively, the deposits may have resulted from a loss of fines (erosion) from the area behind the abutment (below the BAS) due to surface water infiltration through joints or cracks in and around the bridge approach slab and adjacent pavements.

Most of the shoulder drains which are parallel and adjacent to the wing walls were in need of maintenance. Soil and debris accumulation around and on top of the drains was prevalent in several places. Vegetation had also taken root in the soils around and on top of the drains at many locations. Separations were also observed between the concrete shoulder drains and the wing walls. These joints (separations) vary in width and were not filled (sealed) at the time of our visit. In many instances, it was also evident that the shoulder drain had experienced some settlement (dropped) or displacement relative to its original position along the wing wall.

A few rectangular “holes” (penetrations through the bridge deck) were observed adjacent and along the concrete bridge rail. The penetrations appeared to be 2 to 3 inches in one dimension and 3 to 4 inches in the other. It is not clear if these holes were designed to be there (for surface water drainage), or if these penetrations were inadvertently made by form supports which penetrated through the concrete bridge deck. In either event, these holes allow a portion of the storm water that may accumulate on the bridge deck during a rain storm to discharge through the bridge deck to the ground surface or roadway below.

Bridge #2 - Loop 224 at FM 225

This location consists of two separate two-lane concrete bridges for northbound and southbound traffic over FM 225 (Durst Road). This bridge site is located in the southwestern part of the city of Nacogdoches (Nacogdoches County). All of our observations were made on the western bridge which carries the southbound traffic. Both lanes on this bridge are used for through traffic. The subject bridge has a concrete bridge approach slab (BAS) on the approach and departure sides of the bridge. The pavement section on either side of the BAS consists of approximately 4 to 6 inches of asphaltic concrete pavement (ACP) over 12 inches of flexible base material.

Severe distress was observed in the ACP on the approach side of the BAS, predominantly in the inside (right) lane. The concrete BAS on the approach side of the bridge was in relatively good condition with only minor cracking being observed at the time of our visit. This could be due, in part, to the fact that a precast concrete pavement section (panel) was installed by Uretek about 2 years ago at this location to repair a damaged section of the BAS.

Plans were apparently underway to repair the damage to this bridge in much the same way as it was done at Bridge #1. Paul indicated that Uretek proposed to repair the BAS at this location at a much reduced cost to TxDOT in exchange for the opportunity to demonstrate the speed, effectiveness and durability of their repair method.

According to Paul, the original damaged section of the BAS was sawn out and removed, and then the soil was excavated to a depth slightly greater than the thickness of the new panel. The precast panel dimensions were on the order of 10 to 12 feet square and encompassed a portion of the right and left lanes at the interface with the ACP.

Upon completion of the excavation, the new panel was set in place using a crane, and leveled (lifted) into its final position using foam under pressure. The precast panel was then “stitched” into place along the remaining three sides of the BAS. In essence, the panel was “connected” (stitched) to the BAS using thin rigid perforated fiberglass sections (analogous to dowel bars). The fiberglass sections were then placed into sawn grooves (of uniform spacing, depth and penetration) with a 2-part epoxy across the BAS/precast panel joints.

Based on our observations and discussions with Paul, the panel has performed very well with limited distress in the two years that it has been in service. Paul did, however, express a concern with the load carrying capacity and potential displacement (compressibility) of Uretek’s foam over time under repetitive loading from heavy trucks.

The majority of the concrete shoulder drains that we observed had not been maintained. Many drains had become ineffective due to a buildup of soil and debris on and around the drains and a complete overgrowth of vegetation. Some lateral displacement of the concrete drains had also occurred away from the wing wall and collection point at the bridge deck level. We also observed significant cavities (voids) beneath some of the concrete drains and adjacent pavements which resulted from erosion.

Rectangular “holes” (penetrations through the bridge deck) were observed adjacent and along the concrete bridge rail similar to those observed at Bridge #1. It is not clear if these holes were designed to be there (for surface water drainage), or if these penetrations were inadvertently made by form supports which penetrated through the concrete bridge deck. Unlike Bridge #1, space had also been provided between the concrete bridge rail panels. In any event, these holes and gaps allow a portion of the storm water that may accumulate on the bridge deck during a rain event to discharge through the bridge deck to the ground surface or roadway below.

Bridge #3 – US Highway 69 Business (Kurth Drive) at Southern Pacific Railroad (SPRR)

This location consists of two separate two-lane concrete bridges for northwest (north) bound and southeast (south) bound traffic over the Southern Pacific Railroad (SPRR). The railroad consists of two separate tracks which run transverse to the alignment of the bridges.

The bridge site is located in the northwestern part of the city of Lufkin (Angelina County) very near the intersection of Loop 287 and US Highway 69 North. The eastern bridge deck which carries northbound traffic has been topped with an asphaltic concrete (AC) overlay. The western bridge deck which accommodates the southbound flow of traffic did not have an AC overlay on the concrete deck.

Both bridges have concrete bridge approach slabs (BAS) on the approach and departure sides of each bridge. It should also be noted that new Portland cement concrete (PCC) pavements had recently been constructed on the north side of both bridges (BAS’s) as part of another construction project. The pavement on the south side of the bridges (BAS’s) appears to be asphaltic concrete pavement (ACP).

The BAS's on the western bridge appear to be in fair condition with some moderate map cracking in these slabs. The joint between the new PCC approach side pavement and BAS looked very good (at the same level). There was evidence of an old AC level up course on the BAS at this location.

The joint between the BAS and the south side of the bridge deck had a space on the order of 6 to 8 inches. It appeared that several attempts had been made to fill this extremely wide gap with AC materials and crack sealants. It also appeared that AC level ups had been placed over a portion of this BAS to mitigate a previous bridge bump problem. A significant change in elevation (bridge bump) was evident in the main lanes as well as the inside (right) shoulder. Asphaltic concrete paving materials had been used to smooth this fairly abrupt change in elevation.

Cracking in the concrete BAS's on the eastern bridge could not be observed due to the presence of an AC overlay. Severe cracking and distortion of the AC overlay was observed at the interface between the BAS and the bridge deck. A hump or mound of paving materials had been built up at this location creating a significant bridge bump. The original joint at this location (beneath the AC overlay) may also likely be very wide, similar to the exposed joint at the south end of the western bridge. The eastern face (edge) of the concrete bridge deck and abutment at this location has experienced severe deterioration (spalling and exposed reinforcing steel) where the steel bridge beams and concrete abutment come together.

Numerous open joints were observed where bridge abutments, wing walls, BAS's and pavements abut each other. Open cracks were also observed in the BAS's and pavements. Several voids and holes were also present along the edges of the shoulders at BAS/bridge/pavement joints and around some of the wooden guard rail posts. These voids and holes have obviously provided pathways for storm water (surface water runoff) to undermine (erode) the soils beneath and adjacent to the abutments, wing walls and concrete riprap (erosion protection). It was evident that several attempts had been made to seal these joints with limited success.

An area of collapsed concrete riprap was observed beneath the western side of the eastern bridge near the southern end of the bridge. The area of collapse encompassed a circular plan area on the order of 20 to 30 feet. The abutment cap in this area had been exposed and undermined at the location of the riprap collapse. The erosion at this location extended to a depth up to 6 feet in places beneath the original riprap surface.

Severe undermining up to a depth of 4 feet was also observed along the edge of the concrete riprap along the western side of the western bridge at the south end. Large accumulations of soil fines were also evident at the base of the slope in the area of the railroad tracks. Paul indicated that maintenance crews have had to remove loose fines (soils) that have accumulated in and around the railroad tracks in the past to facilitate adequate ground and track clearance for the trains that have to pass beneath these bridges.

A significant quantity of debris including soil, pine needles, bark, twigs and vegetation was observed to accumulate in "mounds" and windrows along the inside (low side) of the BAS's

and adjacent pavements outside the limits of the bridge decks. These mounds of material in some cases have altered the proper flow of storm water to appropriately designed and protected drainage ways, discharge points and slopes.

Bridge #4 – FM 1271 near Loop 287

The bridge on FM 1271 is a relatively short (less than 50') three-lane structure over a creek which is located approximately ¼ mile west of Loop 287 in the western part of the city of Lufkin (Angelina County). The middle lane is a continuous left turn lane with westbound and eastbound traffic being carried by the two outside lanes.

The bridge is an older cast-in-place (CIP) reinforced concrete structure that appears to be supported by steel H-piles at both abutments and a center bent. The original concrete deck has been overlaid with asphaltic concrete pavement (ACP). It was evident along the edge of the pavement near the bridge that the asphalt had been tapered (thickened as one approaches the bridge) to minimize a differential settlement (bridge bump) problem in the past. The bridge was not constructed with bridge approach slabs (BAS's). The bridge rails are continuous and made of reinforced concrete. The roadway on either side of the bridge appears to be constructed of ACP.

Based on our observations beneath the bridge (in the creek area), it was evident that severe erosion, loss of fines and undermining of the bridge abutments and wing walls had occurred in the past which apparently led to settlement of the roadway outside the limits of the bridge. Repairs to stabilize the roadway, retain the soil behind the abutments, mitigate the damage and minimize future erosion appear to have been made after the original bridge construction. This appears to consist of a row of steel guard rails that have been placed behind the steel H-piles from the base of the concrete abutments (pile caps) to an undetermined depth into the creek channel. Several other sheets of material including metal road signs have also been placed behind the H-piles to further stabilize additional localized areas of erosion (scour).

Some undermining (scour) beneath the wing walls was also observed at the ends of the bridge. This appears to be occurring at points where storm water naturally drains off the bridge deck and adjacent pavements into the creek. Some moderate cracking was observed in the outside (right) wheel path of the approach pavements which may be indicative of base failure. These cracks in the pavement may also be providing a pathway for surface water into the base materials below the pavement. The pavement-bridge joints were in good condition at the time of our visit with only minor cracking apparent and a minimal difference in surface elevation.

Bridge #5 – FM 819 near US Highway 59

The FM 819 bridge is a severely skewed three-span two-lane roadway with wide shoulders (minimum 8') over a curve in a creek. The bridge is located approximately 3 miles south of Loop 287 and one mile northwest of US Highway 59 near the southern part of the city of Lufkin (Angelina County).

The bridge is a relatively new cast-in-place (CIP) reinforced concrete structure that was cast using pan-type forms and has a concrete BAS at each end of the bridge. The pavement wearing course outside the limits of the BAS's appears to be a surface treatment or asphaltic concrete with at least one seal coat application. The bridge has an open metal guard rail system which will allow surface water flow off the sides of the bridge deck.

It appears that this bridge has experienced a bridge bump problem in the past. This was evidenced by the fact that a tapered AC overlay had been constructed up to the BAS's which thickened as one approaches the bridge (one could see the taper/thickening because the shoulders weren't overlaid).

The BAS's were in very good condition (very little cracking). There was a slight bump (change in elevation) where the asphalt pavements abut the BAS's with only minor transverse cracking at this joint. To lessen the bump (transition) at some point in time, maintenance forces apparently constructed an AC level up course on portions of the BAS's. Concrete pavement and bridge deck joints were sealed and generally in good condition.

Based on our observation beneath the bridge, it was evident that significant levels of storm water flows in this creek during high intensity rainfall events. Concrete riprap had been installed as slope protection below the abutments to minimize erosion and scour. Paul indicated that a portion of the edge of this riprap had been undermined in the past and has subsequently been repaired.

Likely due to the fact that this bridge is sited at a curve or "bow" in the creek, large quantities of soil fines have been deposited on the riprapped slopes resulting in a very uniform berm of soil material between one of the abutments and the bents (on the order of 20' wide and 6' high).

Bridge #6 – SH 103 at Jack Creek

The bridge on SH 103 is a relatively short (less than 50') two-lane structure over Jack Creek which is located approximately 1-1/2 miles northwest (west) of Loop 287 (and the city of Lufkin) in Angelina County. The roadway is comprised of two 12-foot lanes to accommodate eastbound and westbound traffic with relatively wide shoulders on the order of 8 to 10 feet.

The bridge is a cast-in-place (CIP) reinforced concrete structure that appears to be supported by precast concrete piles at both abutments and a center bent. The original concrete deck has been overlaid with asphaltic concrete (AC). The bridge was not constructed with bridge approach slabs (BAS's). According to Paul, the bridge rails are comprised of a "half Jersey barrier" (Type 502) of continuous concrete. The roadway on either side of the bridge is ACP. It was apparent that pavement repairs or patches had been made at one end of the bridge in both lanes which may be indicative of a bridge bump problem in the past.

Rock riprap had been installed as slope protection beneath the bridge abutments in the creek channel. Based on our observations, it was evident that moderate to severe erosion, loss of

fining and undermining of the bridge abutments had occurred in the past, in part, from storm water flow in the creek. This was more pronounced at one of the abutments where there was a vertical separation on the order of 2 to 3 feet between the rock riprap and the bottom of the bridge abutment. It is certainly possible that a portion of this separation may have occurred as a result of settlement of the soils around the bridge structure. It appears that some type of underpinning (possibly grouting) had been installed behind the concrete piles beneath the bottom of the abutment (pile cap) to close the “separation” and minimize future undermining and erosion at the more severely affected abutment.

It is also possible that some of this erosion may have occurred as a result of surface water (storm water) flow on the bridge deck and adjacent pavement. Possible scenarios include infiltration through the bridge-pavement joints and through cracks or voids in the pavement (which may be partially or completely obscured by the pavement patching above). It is certainly clear that a portion of the erosion and undermining at the ends of the bridge is due to storm water runoff being discharged off the pavement and bridge deck surface into the creek.

Some minor to moderate cracking was also observed on one side of the bridge in the ACP (patched areas) between the end of the bridge and the pavement. Cracking was also apparent around a patch on the shoulder which may be indicative of previous slumping of the fill or minor slope instability. The pavement-bridge joints were generally in good condition at the time of our visit with only minor cracking apparent and a minimal difference in surface elevation.

A significant quantity of debris including soil, pine needles, bark, twigs, vegetation and other materials has accumulated in “mounds” and windrows along the outside edge of the pavement (shoulders) on the bridge deck (at the concrete guard rails) and outside the limits of the bridge (along the base of wooden posts and metal guard rails). This buildup of material in the areas where the guard rail transitions from a continuous (concrete rail) to an open (wooden posts and metal rail) system has altered and at times blocked the flow path of storm water to the appropriate discharge points.

Bridge #7 – Loop 287 at US Highway 69 (Southeast)

The subject bridge is located in the southeastern part of the city of Lufkin (Angelina County) and was constructed on an embankment fill to provide a grade separation over US Highway 69. The bridge was designed to provide two lanes with wide shoulders on each side of a concrete Jersey barrier separating northwest (north) bound and southeast (south) bound traffic on Loop 287.

Concrete bridge approach slabs (BAS's) have been constructed at this location. The pavement surface on either side of the BAS's appears to be asphaltic concrete (AC). A continuous concrete bridge rail has been provided within the limits of the bridge deck and BAS's, with wooden posts and metal rail to the base of the embankment.

At the time of our visit, TxDOT maintenance forces were in the process of constructing an AC overlay from the ends of the BAS's to the base of the embankment to repair pavement distress at the BAS interface and to mitigate the bridge bump problem. The crew had apparently milled the pavement down to its original grade before installing the tapered overlay. It also appears that AC overlays or level ups have been constructed over the concrete BAS's at some point in time, however, these materials had been removed at the time of our visit.

A significant quantity of debris including soil, pine needles, bark, twigs, vegetation and other materials has accumulated along the outside edge of the pavement (shoulders) outside the limits of the bridge (along the base of wooden posts and metal guard rails). This buildup of material has contributed to altering and at times blocking the flow path of storm water to the appropriately designed drainage ways and discharge points.

Concrete shoulder drains have been provided at this bridge location to channel a portion of the surface water runoff from the bridge deck (off the bridge) to a suitable discharge point below the abutments. It appears that storm water is intended (in part) to flow off the bridge deck to a collection point at the top of the shoulder drains. This collection point is typically located at the transition where the continuous concrete bridge rail ends and the open guard rail (wooden posts and metal rail) begins.

The shoulder drain configuration (design) appears to be inadequate for the intended purpose. The shoulder drains at the site were found to be in poor condition and poorly maintained. A significant quantity of debris (similar to what is described above for the shoulders) was found in large quantities on the shoulder drains. Vegetation had overgrown the drains at many points. Additionally, the joints between the shoulder drains and the wing walls were found to be open (which could allow infiltration of water) even though previous attempts to seal these joints had been made.

Bridge #8 – Loop 287 at SH 103 (East)

The subject bridge is located in the eastern part of the city of Lufkin (Angelina County) and was constructed on an embankment fill to provide a grade separation over SH 103. The bridge was designed to provide two lanes with wide shoulders on each side of an open metal guard rail system separating northbound and southbound traffic on Loop 287.

Concrete bridge approach slabs (BAS's) have been constructed at this location. The pavement surface on either side of the BAS's appears to be asphaltic concrete (AC). A continuous concrete bridge rail has been provided within the limits of the bridge deck and BAS's, with wooden posts and metal rail to the base of the embankment.

At the time of our visit, it appears that TxDOT maintenance forces had recently constructed AC overlays from the ends of the BAS's to some point down the embankment slope to repair pavement distress at the BAS interface and to mitigate the bridge bump problem. The crew had apparently milled the pavement down to its original grade before installing the tapered overlay. It also appears that AC overlays or level ups had been constructed over the concrete

BAS's at some point in time, however, these materials had been removed at the time of our visit.

Concrete shoulder drains have been installed along the wing walls at locations where concrete riprap (slope protection) has not been provided adjacent to the wing walls. An obstruction to surface water drainage flow and discharge away from the bridge abutments and BAS's was created at this location (similar to Bridge #1) when a monocurb and thriebeam guard rail system was retrofitted (added) at the end of the concrete bridge rails. In this instance, the contractor apparently installed the monocurb across the drainage collection point at the top of the shoulder drains, essentially cutting off surface water flow to the shoulder drains.

The shoulder drain configuration (design) appears to be inadequate for the intended purpose. The shoulder drains at the site were found to be in poor condition and poorly maintained. A significant quantity of debris (soil, rocks, pieces of broken concrete, twigs, vegetation and other materials) was found in large quantities on the shoulder drains. Vegetation had overgrown the drains and debris at many points. In addition, the joints between the shoulder drains and the wing walls were found to be open (which could allow infiltration of water) even though previous attempts to seal these joints had been made.

Unlike Bridge #7, it was apparent that significant settlement (or movement) of the embankment soils had occurred around the bridge structure. This was evidenced by the difference in elevation between the current levels (height) of the shoulder drains as compared to the levels of the old crack sealant materials which have remained (as a marker) on the wing walls.

Paul indicated that free water was observed in the wooden guard rail post excavations at the time of drilling and installation. The posts were installed in the summer of 2004 in excavations approximately 4 feet deep. The water level was observed to be approximately 6 to 8 inches below the adjacent ground surface.

It should also be noted that the area (ground surface) around the guard rail post excavations (up to the adjacent pavement or shoulder) had been paved (sealed) with asphaltic concrete materials. This appears to be a very good practice which may limit the infiltration of surface water into the ground around these post excavations (ground penetrations). If these areas are not sealed, the post excavations could provide a source of water for infiltration into the base and subgrade materials beneath the adjacent pavements.

Bridge #9 - US Highway 59 at Baskins Loop (US 59 Business)

This location is comprised of two relatively long (300 to 400 feet) concrete bridges which are located approximately ¼ mile north of Pan American Drive (US 59 Business) in the southern part of Livingston, Texas (Polk County). These bridges span over a railroad and a 2-lane roadway referred to as "Baskins Loop." The eastern bridge has two through lanes for northbound traffic (left and middle) and one lane (right/inside) for exit maneuvers. The western bridge has two lanes for southbound traffic. The site reconnaissance was limited to

the southern ends of both bridges south of the Baskins Loop. This would include observations of the approach side and the departure side of the eastern and western bridges, respectively.

Concrete bridge approach slabs (BAS's) have been constructed at this location with a moderate skew at the expansion joint over the abutment. The pavement surface on either side of the BAS's is asphaltic concrete (AC). A continuous concrete bridge rail has been provided within the limits of the bridge deck and BAS's which transitions to an open-rail system (wooden posts and metal rail) beyond the BAS's.

Paul indicated that the BAS's had "cracked up" fairly extensively before they were overlaid. The BAS on the approach side of the eastern bridge exhibited much more significant damage than the BAS on the departure side of the western bridge. It was evident that the majority of the eastern bridge approach had been overlaid more than once, while only a small percentage of the western bridge approach had been overlaid in the area around the pavement-BAS interface (joint).

The interface between the pavement and the BAS on both bridges exhibited significant cracking in the AC along and on both sides of the joint. Depressions and humps were also observed along this joint on both bridges. Severe cracking was observed in the concrete BAS along and within one foot of the bridge deck-BAS interface on the eastern bridge. The exposed concrete BAS on the departure side of the western bridge was in very good condition outside the limits of the pavement-BAS interface.

The shoulder drain located on the eastern side of the eastern bridge was observed to be severely damaged (non-functional) at the time of our visit. This appears to be due, in part, to severe erosion at the top of the shoulder drain where a portion of the bridge deck's surface water runoff is diverted toward the shoulder drain. This diversion point occurs between the concrete bridge rail and the first wooden guard rail post. The erosion appears to have led to the collapse and breaking up of the concrete at the top of the drain. A very large hole and cavity was also created beneath the shoulder drain and pavement shoulder at that location. It was also evident that the shoulder drain had moved downward and laterally away from the wing wall primarily as a result of the erosion. Settlement of the embankment soils may have also contributed to this movement.

Concrete breakage and spalling was also observed on the eastern face of the bridge where the bridge deck and wing wall come together above the subject shoulder drain. Observations beneath the bridge revealed that the concrete riprap had moved out of and away from (down slope) the keyway that was formed into the abutment to keep the riprap in position. Paul indicated that he did not like this abutment keyway/riprap design feature.

The shoulder drain located on the western side of the western bridge was also found to be severely damaged and non-functional. The concrete shoulder drain had been broken into several pieces and had moved away from the wing wall and dropped below the originally constructed flow line by as much as one to three feet in both directions. Large deposits of

soil and debris covered this “former” shoulder drain which was completely overgrown with vegetation.

The top of the concrete riprap beneath this bridge had also moved out of the abutment keyway and dropped below its originally constructed position by as much as 3 to 6 inches in both directions. Dense vegetation was found to be growing in the crevice between the riprap and the abutment.

Several open joints and separations of varying dimensions were observed between various components of the bridge structure (wing walls, abutments and bridge deck) and the BAS's, pavements, riprap and shoulder drains at both bridges. These open joints and separations (if not maintained and sealed) provide potential entry points for water which can lead to erosion and undermining of the bridge structure as well as saturation of the subgrade and aggregate base materials beneath pavements and slabs.

4.5 Houston District

The Houston District visit took place on December 21 and 22, 2004, and began with a meeting between the Texas Tech University researchers and Michael W. Alford, P.E., Director of Maintenance in the Houston District.

The meeting included discussions on the following topics: (a) Houston District's general experience with bridge approach performance, (b) Specific maintenance related problems, (c) Past and present practices in bridge approach design and construction within the district, and (d) The impact that these different designs and construction methods have had on approach performance. Mr. Alford's long association with TxDOT, Houston District proved to be extremely valuable in these discussions.

The conditions found in the Houston area are particularly unfavorable to the construction and maintenance of transportation structures. First, Houston receives a lot of rainfall. Secondly, the soil conditions found in the region are poor. Weak, clay soils are abundant in the area. Third, traffic conditions in the Houston metropolitan area are as severe as in any other location in Texas. Therefore, the maintenance engineers in Houston are faced with special challenges. As a result, the Houston District has always been on the forefront in search of new solutions and implementing them.

Among the new designs that the Houston District has implemented, the following were of special interest to this research study.

- (a) Underdrain system underneath the approach slab and pavement
- (b) Use of Cement Stabilized Sand (CSS) wedge behind abutment walls
- (c) Modified design dimensions for surface water drainage flume

A detailed discussion of these features has been included in Chapter 5 of this report.

The next task included visits to selected bridges in the Houston District that had suffered bridge approach damage. Obviously, finding bridges that would meet the research project requirements was not difficult in the Houston District. However, it was also necessary that the selected bridges would be located within close distance to each other so that the review could be completed within a reasonable time. Taking both of these requirements into

consideration, Mr. Alford selected three bridges that were all located on the same stretch of highway. These three bridges, according to Mr. Alford, have had recurrent bridge approach performance problems. The three selected bridges were:

- (a) US-290 (East Bound) Overpass at FM362
- (b) US-290 (East Bound) Overpass at Kickapoo Road
- (c) US-290 (West Bound) Overpass at Hegar Road

The locations of these three bridges are shown in Figure 4.7. While it was true that these bridges have had significant problems with regard to approach damage, none of the severe problems that had been experienced were evident at the time of the visit because necessary repairs had already been completed.



Figure 4.7 Locations of Bridges Visited in The Houston District

4.5.1 US-290 (East Bound) Overpass at FM362:

The approach at the entrance to the bridge on the west side was inspected during this visit. The bridge approach design consisted of a concrete approach slab and a concrete approach pavement with wide flange terminal anchorage system. The approach slab had been reconstructed on the left travel lane approximately 3 months prior to the visit. Moreover, the entire approach slab had been raised and leveled using URETEK slab jacking method about 4

years prior to that. In addition to the above, there were signs of recent repair work completed on the concrete riprap. Some sections of the riprap adjacent to the wingwall had been raised using slab jacking with conventional cement grout. Thus, it was clear that this particular bridge approach has had a history of recurrent failures.

The concrete side rails on the bridge have been provided with drain slots that allow surface runoff from the bridge to drain laterally onto the concrete riprap below. However, Mr. Alford pointed out that the width of the concrete riprap was not adequate to catch the lateral drip during a heavy downpour. This issue must be addressed in future riprap designs.

A second design deficiency that was identified by Mr. Alford involved the size of the surface water drainage flume. Two main problems have been identified in the flume design. First, the curb around the flume has been found to be too short to contain the runoff that is generated during a heavy rainfall. In other words, the stream of water will arrive at the bridge end with such velocity that it would jump over the curb as it changes direction into the flume. Secondly, observations made by Houston District maintenance personnel also indicate that the length and width of the flume must also be increased in order to ensure that water is contained with the drainage flume.

4.5.2 US-290 (East Bound) Overpass at Kickapoo Road:

The approach at the entrance to the bridge on the west side of the bridge was inspected during this visit. The bridge approach design included a concrete approach slab. According to the plans the approach pavement consisted of a reinforced concrete pavement though it appeared to have been overlaid with asphalt concrete at a later time. It is reasonable to assume that the bridge approach had settled and asphalt overlays had been used to remedy the problem. The bridge approach appeared to be performing well at the time of the visit. With the exception of erosion that was observed near the toe of the concrete riprap no other problems were evident.

A unique feature in this bridge was a modified design used for the surface water drainage flume. Because of the deficiencies identified in the standard design, the Houston District had increased the curb height, length and width of the drainage flume. This modified design, according Mr. Alford, has performed well.

4.5.3 US-290 (West Bound) Overpass at Hegar Road:

The approach that was inspected in the third bridge was the entrance to the bridge on the east side. The bridge approach design was similar to that of two previous bridges except that the approach pavement has been identified as asphalt concrete pavement (ACP) in the original plans. In this bridge there was clear evidence that the bridge approach had undergone large settlements since its initial construction. The approach pavement had been overlaid with asphalt concrete repeatedly and an accumulated thickness of about 6-inches of ACP could be seen over the original pavement. There was a noticeable dip in the overlay even at the time of the visit.

A feature that was unique in this bridge was a downdrain system that was provided in the shoulder between the east and west bound travel lanes. Such a downdrain system was

necessary because the bridge was located in a superelevated section of the highway. Therefore, drainage from the bridge and the adjacent pavement occurs in the direction of the center rather than to either side. Therefore, the surface drainage is collected in drainage basins and then carried vertically down through the embankment and released into a culvert located near the toe of the embankment.

CHAPTER 5

SITE ASSESSMENT AND SELECTION OF THE OPTIMUM REPAIR STRATEGY

5.1 Introduction

There are several important factors that must be taken into consideration when developing a suitable strategy for the repair of a damaged bridge approach. These include: (a) severity or level of deterioration, (b) relative costs associated with different repair alternatives, (c) time taken to implement repair and interruption to traffic. Another, an equally important consideration, is the ‘root cause’ of failure. In other words, various mechanisms that may have lead to the deterioration of the bridge approach must be carefully examined so that the primary cause or causes of failure can be identified. This step is essential so that a repair strategy can be selected to address the specific ‘root cause (or causes)’ and hence avoid future recurrence of the problem. A tool that will be very beneficial to the maintenance engineer in accomplishing the above goal is a systematic procedure that guides him through the site assessment and data collection process. Therefore, the primary thrust in this research effort was placed on the development of such a site assessment protocol. This chapter describes the steps followed in the development of the above protocol.

The development of the site assessment procedure and the evaluation of available bridge repair strategies were accomplished based on the information collected from many different sources. First of all, a significant amount of published literature on this subject can be found in technical reports and articles printed in magazines, periodicals, conference proceedings and journals. These publications were collected and carefully reviewed so that pertinent information could be taken and analyzed. A second source that is replete with useful information on research studies conducted on bridge approach problems and various repair alternatives is *the internet*. The internet was particularly useful in identifying various new commercial products and processes that may be used during the repair project. In addition to review of published information, the researchers spent a considerable amount of time interviewing TxDOT and other DOT engineers experienced in bridge approach maintenance and repair activities. The researchers have relied heavily upon their experience and the lessons learned from previously completed repair and reconstruction projects in arriving at a systematic approach for assessment of deteriorated bridge approach sites and selection of suitable repair strategies.

Chapters 2, 3 and 4 of this report documented the findings from the literature review, interviews with maintenance engineers and visits to field sites. This chapter focuses on the use of the information presented earlier to develop procedures for site assessment and repair strategy selection. A site assessment protocol that can be used by TxDOT maintenance personnel for the purpose of evaluating bridge ends with respect to water intrusion damage is included in Appendix F.

5.2 Role of Water Intrusion in Bridge Approach Degradation

As described in previous chapters, there are numerous mechanisms that can contribute to early deterioration of bridge approaches. Some of these occur regardless of the presence of water intrusion at the approach while others are primarily driven by intrusion of water.

There is also a third category of degradation mechanisms that can occur independently but are greatly accelerated by the intrusion of water. Therefore, one of the main objectives of the site assessment is to determine the relative role that water intrusion has played in causing degradation of a given bridge approach. The emphasis that will be placed on minimizing water intrusion during the repair will depend on the findings of the site assessment.

Among the different causative mechanisms that lead to bridge approach failure, the one that was cited most often by TxDOT engineers was the compression of the embankment fill resulting from inadequate compaction during construction. Such compression will cause settlement of the approach relative to the bridge deck. However, if an approach slab is present, then the differential settlement will not be seen immediately. Instead, a void will form underneath the approach slab. Then cracks will begin to form in the approach slab due to lack of soil support. If suitable remedial action is not taken promptly, the cracks will continue to grow and eventually cause failure of the slab. A second mechanism that was cited frequently was the inadequacy of surface drainage features. This increases the chances of water infiltrating into the subsoil, saturating and weakening it and reducing support for the approach slab. Very often, flowing water aggravates the problem by eroding the fill material away. A third mechanism included the settlement of the natural foundation soil under the overburden weight of the embankment. Settlement of the foundation soil will depend on the compressibility of that material as well as the height of the overlying embankment. A final failure mechanism that was found in literature but was not cited by TxDOT engineers is void space development behind bridge abutments resulting from cyclic movement of the abutment in the longitudinal direction due to thermal expansion and contraction of the bridge. The embankment fill material can subsequently be washed into the void. This problem is considered to be more common in bridges that are provided with integral abutments.

Evaluation of the following factors will help in determining the relative role that water intrusion may have played in causing damage at a given bridge approach site:

- a) *Climatic Conditions at the Bridge Location:* Clearly, the climatic conditions found at the bridge location have great influence in determining how much water intrusion can contribute to approach damage. In the eastern part of Texas, that receives more rainfall, the potential for water intrusion damage is greater than in West Texas.
- b) *Signs of Material Loss:* Any signs of soil erosion would indicate that water intrusion is taking place at the bridge approach. Minimizing water intrusion must receive special attention during repair. Figures 5.1 and 5.2 are examples of soil erosion found during visits to TxDOT bridge sites. Pumping of soil sediments through joints and cracks in the pavement/approach slab has also been cited as a possible mechanism for material removal.
- c) *Evidence of Water Seepage:* Sometimes, water seepage can be seen although there are no signs of material loss accompanying it. Once again, this is a clear indication that there is a water intrusion problem that must be addressed during repair of the bridge approach. These conditions were found in the US-83 Overpass

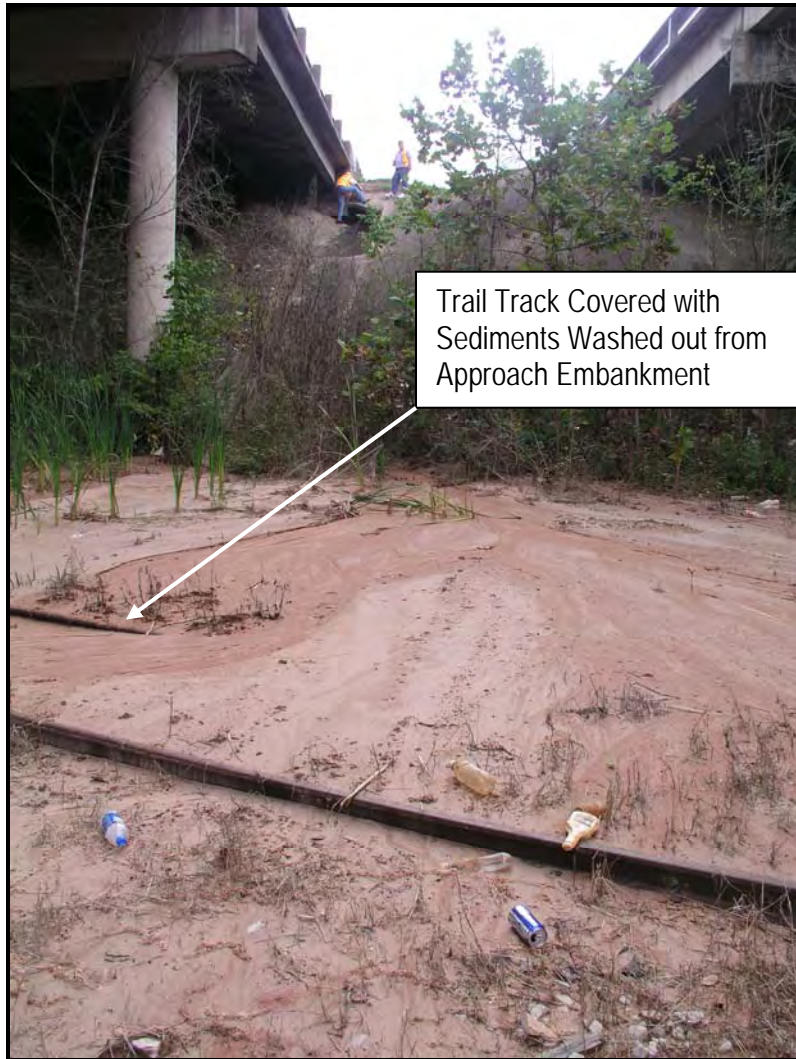

Figure 5.1 Extensive Erosion at Business 69 Overpass over Southern Pacific Railroad in Lufkin District



Figure 5.2 Signs of Embankment Fill Erosion at IH-27 Overpass over 4th Street in Lubbock District

bridge over Antilley Road in the Abilene District. Figure 5.3 shows water seepage found at the bridge site.

- d) *Presence of Water Found during Maintenance Activities:* Evidence of water intrusion is often found during maintenance activities. For an example, workers may find water in holes that were excavated for guardrail post installation. Collecting such information will be useful when determining whether water intrusion is present.
- e) *Points of Access for Water Intrusion:* Poorly sealed or unsealed joints between bridge deck and approach slab, approach slab and pavement, and approach slab and mow strip as well as cracks in the surface layers provide ready access for water to enter into the embankment fill. Water can also enter through other less conspicuous pathways. For example, holes excavated for guardrail posts or road sign support structures, if not backfilled and sealed properly, can allow water to get into the approach fill. This factor overlaps with Section 5.3 which deals with identification of specific water sources. A more detailed discussion on the topic is presented in that section.
- f) *Maintenance History:* Maintenance history can also provide useful clues in determining the extent to which water intrusion may have contributed to the deterioration of a given bridge approach. At many bridge approach sites where settlement of the approach embankment is experienced, the problem becomes less severe with time. In other words, the amount of settlement decreases as the bridge gets older. At these sites there could have been some water intrusion which accelerated the settlement of the fill. However, if the maintenance history suggests that the embankment is approaching stable conditions, then no major water intrusion control measures may be needed. On the other hand, if the problem continues to recur even after many years of maintenance work, further investigation and more extensive repair may be needed.
- g) *Data from Exploratory Boreholes:* Collecting additional data by sampling the fill material and testing the soil in the lab may be considered if the bridge approach deterioration has been severe and persistent. Many factors such as variations in fill material and water introduced during drilling can make interpretation of data difficult. Nevertheless, with proper care, water content and degree of saturation profiles can be established. Such data will be of special value when determining to what extent water intrusion contributed to the problem.

5.3 Controlling Water Intrusion

Once the factors listed in Section 5.2 have been carefully evaluated, the maintenance engineer will have a good idea as to what extent water intrusion has contributed to damage at the particular bridge approach. If it is determined that water intrusion has played a major role in causing damage, then the repair strategy selected must include steps to control future water intrusion. As a first step towards accomplishing this goal, one must identify the primary source of water. In other words,



Figure 5.3 Water Seepage at the US-83 Overpass Bridge Departure over Antilley Road in Abilene District

we must know whether the water is coming from above (i.e. surface drainage from the bridge and the adjacent pavement that enters into the embankment fill through cracks and joints) or from below (i.e. water rising by capillary action through the embankment fill). The first mechanism is by far the most common. The second mechanism can be active in situations where: (a) the ground water table is shallow, and (b) the embankment consists of fine-grained material that is capable of exerting sufficiently large capillary forces. Because of the distinct differences found in the two water sources discussed above, they are treated separately in the sections that follow. Accordingly, Section 5.3.1 deals with surface water control while Section 5.3.2 deals with subsurface water.

5.3.1 Controlling Surface Water Intrusion

Intrusion of surface runoff from the bridge may occur as a result of: (a) inadequacies in the surface drainage system design, (b) improper maintenance of surface drainage system, or (c) improper maintenance of joints, cracks in the approach slab and the adjacent pavement. The following sections discuss each one of the above in detail.

5.3.1.1 Adequacy of Bridge Surface Drainage Design: The design of the drainage system for surface water varies from one bridge to another. In some bridges, the bridge rail allows lateral drainage of surface water while in others the rails do not allow such drainage. Some bridges are provided with scuppers and downpipes that help in draining the surface water from the bridge deck. When alternative drainage features such as those described above are not present, the amount of surface water that is directed towards the bridge end will obviously be larger. The next step would involve review of the drainage features at the bridge end. In most TxDOT bridges, the surface water that reaches the bridge ends is diverted to drainage flumes that take the water down the approach embankment. In many locations, TxDOT engineers have found the drainage flumes to be inadequate. This is particularly true in the eastern part of the state where rainfall is heavy. Two issues that were identified by TxDOT engineers were: (a) inadequate height of the curb and (b) width and length of the drainage flume. These features are shown in Figure 5.4. The curb should be high enough to prevent the water from overflowing as it turns the corner into the drainage flume. Similarly, the length and width of the flume must be large enough so that water is contained within the flume even during a heavy downpour. Another problem that was identified during district visits was the inadequate width of riprap. Figure 5.5 illustrates this problem. In the bridge shown in the picture, the riprap does not extend far enough so that it can catch the lateral drip from the bridge rail. Such lateral drip, according to the TxDOT maintenance engineer, can have sufficient erosive force to cause significant damage. As a final but important point it must be noted that the design should be consistent with the climatic conditions in the region. In other words, a drainage system design that is satisfactory for the Abilene District may not work for the Lufkin District.

5.3.1.2 Proper Maintenance of Surface Water Drainage System: The next important task involves inspection of the surface water drainage system to make sure that it has been well maintained so that it can function properly. The findings from the district visits made during this study suggest that this aspect in bridge maintenance is not currently receiving the attention that it deserves. The drainage flumes were often blocked by accumulation of debris and/or by growing weeds. In some cases, the drainage

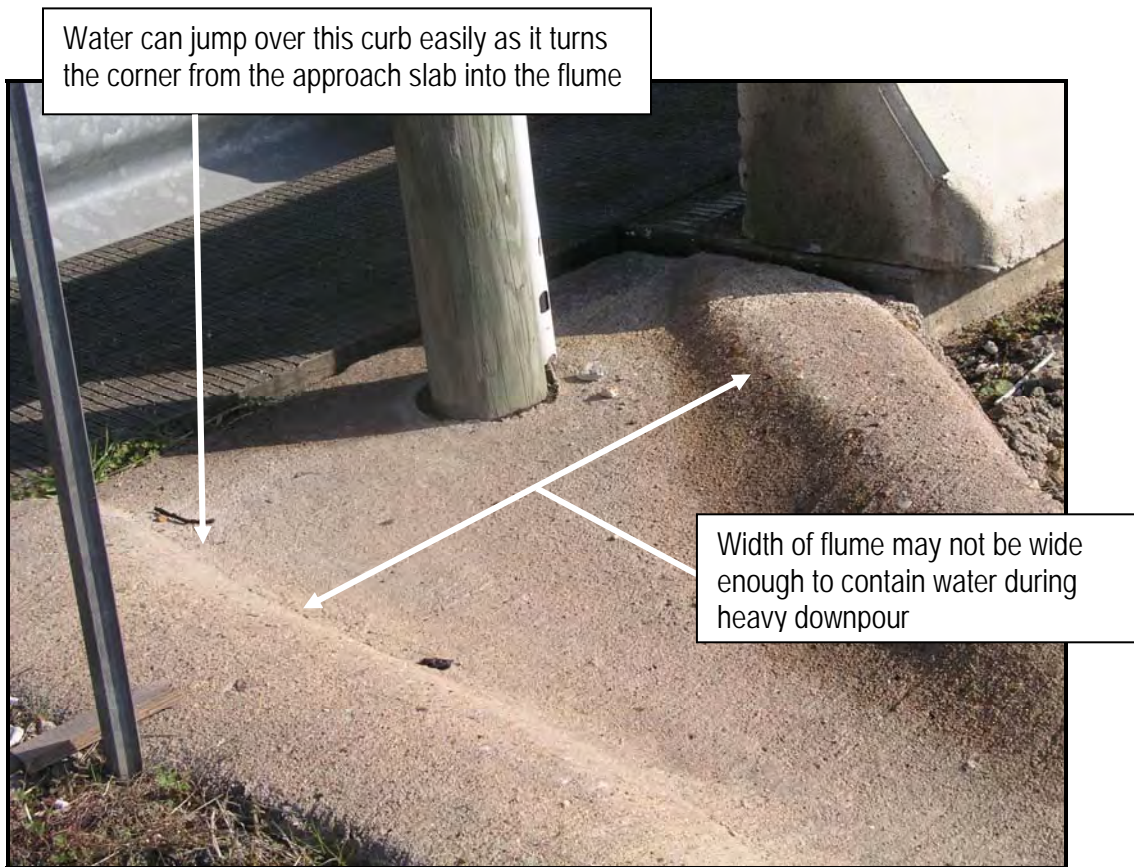

Figure 5.4 Drainage Flume at the Bridge End (Houston District)

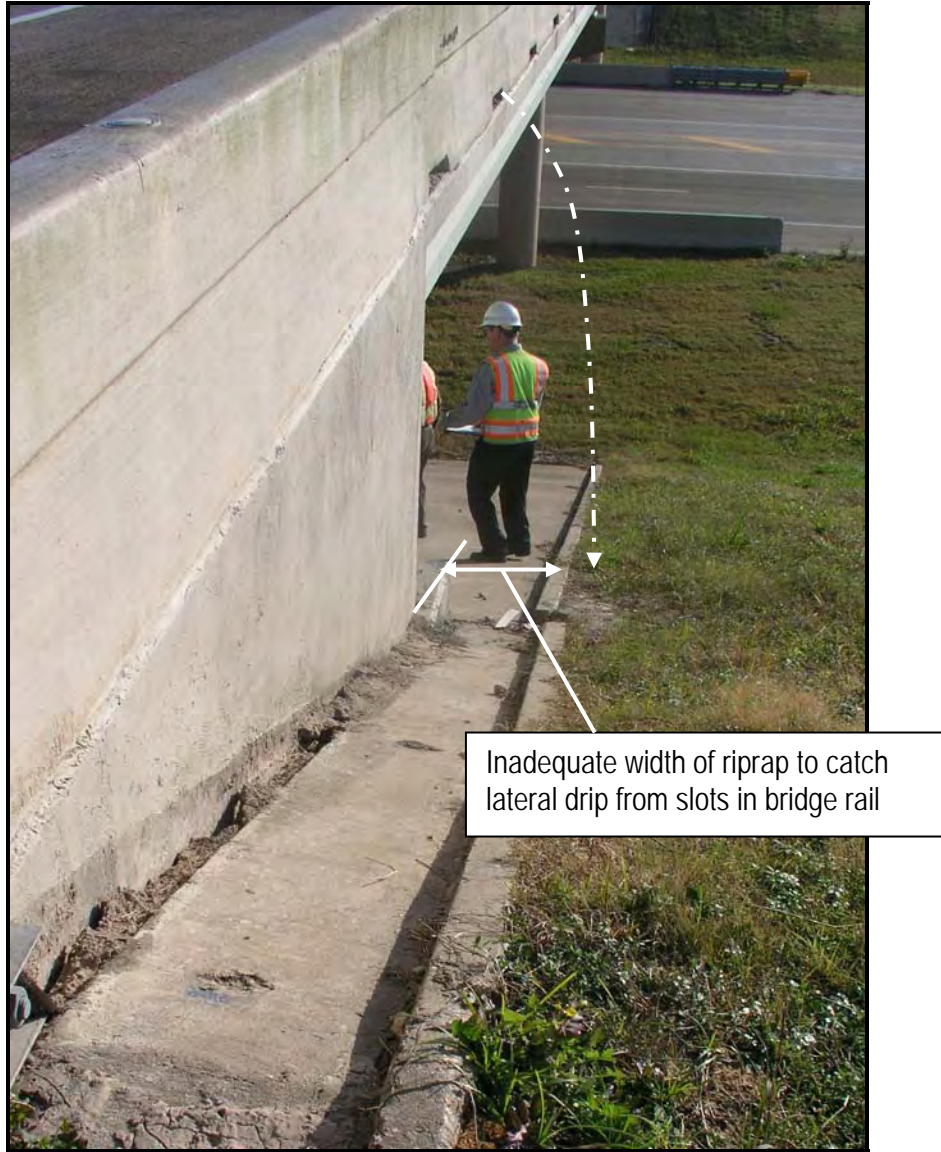

Figure 5.5 Inadequate Riprap Width (Houston District)

flumes were cracked so badly they provided easy pathways for water to enter the embankment fill. Figures 5.6 and 5.7 show examples seen during site visits. In one extreme example where the guardrail system was replaced with the new “monocurb with thriebeam system,” the “monocurb” had been installed in such a manner that it completely blocked the entrance to the original surface water flume. Figure 5.8 illustrates the above problem.

5.3.1.3 Sealing Cracks and Joints: The need for proper maintenance of joints cannot be over-emphasized. Improperly sealed joints and cracks serve as access points for water intrusion. The observations made during site visits leads to the conclusion that, in many bridges, poorly maintained joints and unsealed cracks in the approach slab and pavement contribute significantly to the water intrusion and approach damage problem. For example, Figure 5.9 depicts an approximately 5-in wide joint between the bridge deck and approach slab. Such joints are not common. Nevertheless, this particular example highlights the significance of the role that joints can sometimes play in water intrusion problems at bridge ends. Figures 5.10 and 5.11, on the other hand, illustrate more common problems. Figure 5.11 shows an open joint between the approach slab and the mow strip. The joint occurs where the surface water enters the drainage flume. Therefore, the amount of water that can enter through such an open joint will be particularly large. Such heavy rates of water intrusion can easily lead to erosion of the fill material in the vicinity of the bridge approach.

5.3.2 Controlling Subsurface Water Intrusion

5.3.2.1 Verification of the Presence of a Subsurface Water Source: As mentioned previously, evidence from inspection of many TxDOT bridges that suffer from water intrusion damage suggests that, in the majority of these cases, the problem is due to surface water rather than subsurface water. Nevertheless, the possibility that water can rise from a subsurface source through the embankment fill material by capillary action does exist. The distance or height to which it can rise in this manner is largely controlled by the gradation of the fill soil. Fine-grained soils are capable of exerting larger capillary forces and, therefore water can rise to greater heights through such materials. Therefore, this mechanism of water intrusion is more likely to be active when (a) the groundwater table is at shallow depth, (b) height of embankment is limited and (c) embankment fill consists of fine-grained material. At-grade bridges at stream crossings may often meet these requirements. If it is suspected that subsurface water is the primary mechanism responsible for water intrusion then supporting evidence could be obtained through subsurface drilling and laboratory testing of soil samples. Review of water content and degree of saturation profiles within the embankment will help in the identification of moisture intrusion from the subsurface.

5.3.2.2 Controlling Subsurface Moisture Migration: If the data confirms that moisture migration by capillary action significantly contributes to water intrusion at the specific bridge site, then controlling such subsurface flow will be necessary. However, this cannot be easily achieved during repair because capillary water cannot be drained by gravity drainage systems. The moisture migration can be interrupted by replacing the fine-grained soils with coarse granular material or cement stabilized material immediately below the approach slab and pavement. Such repair strategy, however, is not likely to be



Figure 5.6 Badly Damaged Drainage Flume Allowing Water to Flow Underneath Approach Slab



Figure 5.7 Effectiveness of Drainage Flume Impaired by Weeds and Debris Collection



Figure 5.8 Entrance to Original Drainage Flume Blocked by the Installation of the Monocurb in the New Thrie Beam Guardrail System



Figure 5.9 Poorly Maintained 5-inch Wide Joint between Bridge Deck and Approach Slab



Figure 5.10 An Access Point for Intrusion of Bridge Surface Water Runoff



Figure 5.11 Open Joint between Approach Slab and Mow Strip

cost effective. At the same time, such repair may not be warranted because the capillary flow does not cause nearly as much damage as surface water infiltration. While it does have the potential to weaken the soil by increasing its level of saturation, it does not generate any free water and hence cannot erode soil materials.

5.4 Selection of the Optimum Repair Strategy

Sections 5.2 and 5.3 above described two important steps that must be completed before any work on the development of a suitable repair strategy can be undertaken. In the first step, which is described in Section 5.2, the maintenance engineer would determine whether water intrusion is a major factor that has contributed to the bridge end deterioration. If water intrusion is identified as an important contributor, then he/she would follow the procedure outlined in Section 5.3 to determine whether water comes primarily from the top or from below.

The following sections describe the other factors that must be taken into consideration in the selection of a suitable repair method.

5.4.1 Design of the Bridge Approach

TxDOT uses a number of different bridge approach designs. For example, at the present time it is common practice to provide an approach slab at the transition between the bridge deck and the pavement. However, not all bridges are provided with approach slabs. The preferred practice has changed from time to time as well as from district to district. When an approach slab is not present, the problems due to embankment settlement and fill material erosion are seen more readily. Obviously, the type of remedial work that is undertaken in this situation is quite different from that undertaken when an approach slab is present. Variations in the approach design also occur in the type of terminal joint used. The most commonly used terminal treatments are (a) wide flange steel beam joint and (b) lug anchor terminal joint.

5.4.2 Severity of Damage

The severity of damage is an obvious factor that has important bearing on the choice of a suitable repair strategy. The severity of damage can be assessed based on the level of distress found at the bridge end. Such distress may appear in the form of differential movement (or 'bump'), or cracking and faulting of the approach slab and/or pavement. Briaud et al (2002) used a bump scale rating to quantify the severity of the bump. The extent and severity of cracking and faulting can be determined based on a visual condition survey.

Visual survey and direct measurement of surface distress can provide us with a reasonably good assessment of the extent of damage that the approach and the pavement have suffered. However, before a decision as to the optimum repair strategy can be made, the maintenance engineer must also have a good assessment of the extent of 'hidden' damage. Such hidden damage includes the voids formed underneath the approach slab and the pavement as result of embankment settlement and/or soil erosion. Determining the locations of these voids and their sizes is a challenging task. Among the techniques that have been used for this purpose are:

- (a) *Hyper Optics Void Detection System*: This system developed by URETEK, USA is enclosed in an enclosed mobile detection vehicle. The company claims that scanning can be achieved while the vehicle is in motion. Figure 5.12 shows the mobile detection vehicle
- (b) *Three dimensional Ground Penetrating Radar (3D-GPR) and Slab Impulse Response (Slab IR)*: These two techniques have been used in combination by Olson Engineering company to detect subgrade voids underneath Alpine Dam spillway. Figure 5.13 shows the Alpine Dam spillway being tested by Olson Engineering company while Figure 5.14 shows the results from 3D-GPR and Slab IR testing.
- (c) *Probe Drilling and Video Borescope Probing*: Probe drilling is useful for confirmation of findings from the non-invasive techniques described previously. Video borescope probing takes this a step further by allowing the maintenance engineer to directly observe the voids. It provides visual images that may be captured in VHS or JPEG formats. Figure 5.15 shows a borescope still shot.

5.4.3 Interruption to Traffic

Interruption to traffic is another important factor that must be considered in the selection of a repair method. Some of the repair methods, though relatively more expensive, may be implemented with minimum interruption to traffic. If the bridge requiring repair carries heavy traffic volume, the extra cost associated with the implementation of such a repair may be justified based on the savings on user costs. Similar justification can also be made for those bridges for which alternative detour routes are very long.

5.5 Bridge Approach Repair Methods

5.5.1 Restoring Ride Quality with Asphalt Overlay

Asphalt overlaying is one of the most commonly employed methods of restoring the ride quality of distressed pavements and approach slabs. This type of repair, though effective in remedying the immediate ride quality issue, is not designed to address the root cause of the problem. For example, let us assume that the distress seen in the approach pavement is the result of load-induced settlement of a poorly compacted embankment fill. Then the settlement will continue requiring repeated application of asphalt overlays until the settlement is complete. Nevertheless in some cases, the asphalt overlay may still be the most cost effective solution. Figure 5.16 shows a bridge end that has received multiple applications of asphalt overlay. Asphalt resurfacing will not be an acceptable repair solution for many bridge approach deterioration problems. For example, if the distress seen on the pavement or approach slab is caused by lack of soil support resulting from removal of subsoil by erosion, then overlaying the slab with asphalt will not be an appropriate solution because it does not address the issues related to drainage and soil erosion.

5.5.2 Slab Stabilization

The term, *slab stabilization* refers to a process that involves pumping grout through holes drilled through the slab, in order to fill voids that develop underneath the



Figure 5.12 URETEK Hyper Optics Void Detection System
(Source: URETEK USA)



Figure 5.13 GPR and Slab-IR Testing of Alpine Dam Spillway to Detect Voids Underneath Slab (*Source: Olson Engineering Inc.*)

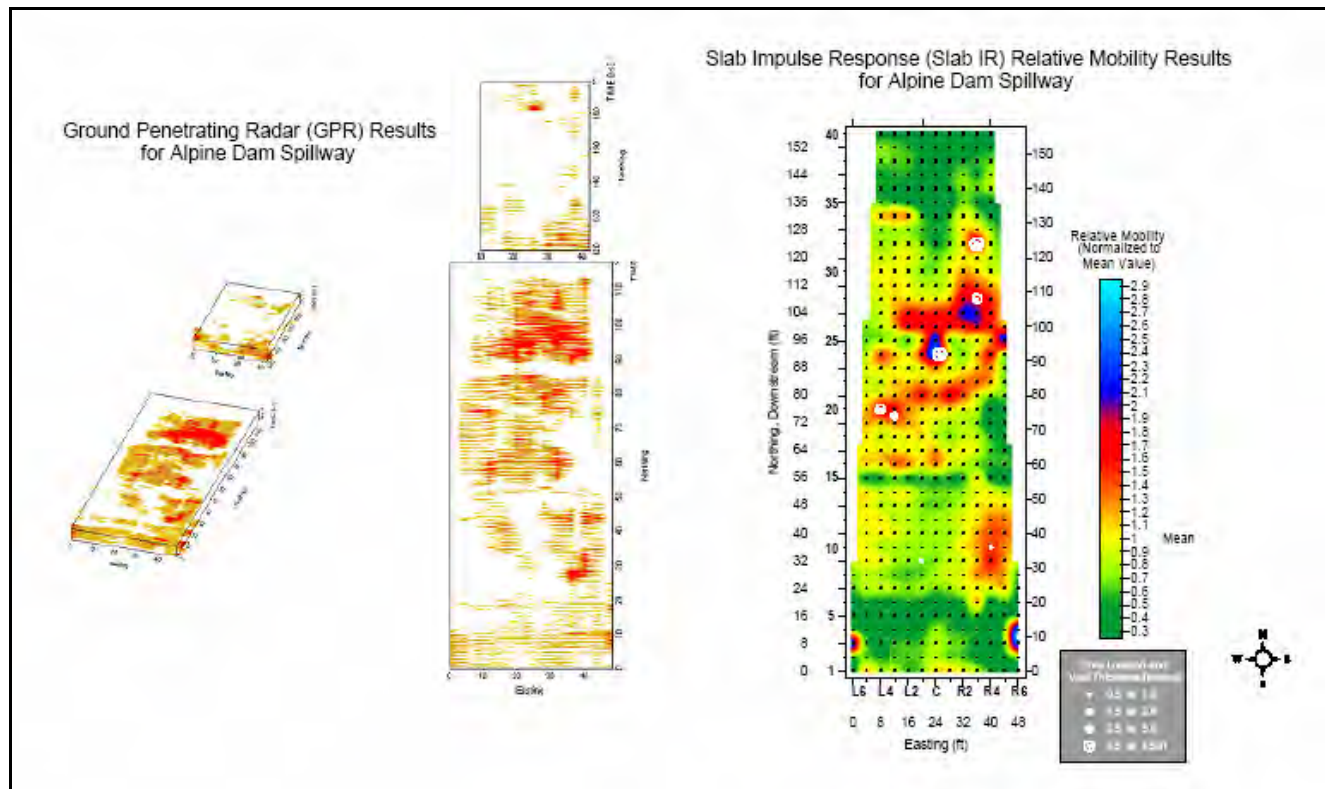

Figure 5.14 Results from GPR and Slab-IR Tests Conducted on Alpine Dam Spillway



Figure 5.15 Borescope Stillshot



Figure 5.16 Multiple Overlays Used to Remedy Bridge End Settlement

concrete slab at joints, cracks, or the edge. The voids are often not much deeper than 3mm (1/8 in.). Several common destructive forces lead to formation of these voids. Heavy traffic loads induce the highest slab deflections near transverse joints and working cracks. These deflections may cause pumping, consolidation, and loss of soil support. Without support underneath the slab, load stresses in the concrete increase and may cause other problems, such as faulting, corner breaks, and cracking. Slab stabilization is also referred to as *pressure grouting, undersealing and subsealing*.

Slab stabilization is considered to be a preventive maintenance activity and should be done prior to the onset of slab damage. Non-invasive testing such as deflection testing, ground penetrating radar and infrared thermography have been used to identify pavements that require grouting. Comparison between deflections before and after grouting is used to verify effectiveness of slab stabilization.

It should be noted that slab stabilization is not the same as *slab jacking*. Unlike slab jacking, this process does not involve raising and/or leveling of the slabs. [Ref. ACPA publication *Slab Stabilization Guidelines for Concrete Pavements* (TB018P)].

5.5.3 Slab Jacking Using Cement Grouts

Slab jacking may be considered an extension of slab stabilization. Slab jacking is used to raise a settled section of the slab to its original elevation. The process, however, is somewhat more involved but is similar to that used in slab stabilization. It involves drilling strategically placed holes in the slab and then pressure injecting cement grout or mud-cement mixtures under the slabs using a positive displacement, non-pulsating type grout pump.

The Figure 5.17 illustrates the basic steps involved in slab jacking. Extreme care must be taken during slab jacking operations to prevent accumulation (“pyramiding”) of the grout under the slab in the immediate vicinity of the injection hole. The grout should raise the slab slowly and with uniform pressure. To accomplish this, an array of holes must be drilled through the slab in a pattern that will permit the lateral flow of grout to penetrate all areas under the slab. The jacking rate should be slow enough to permit grout flow into all existing voids completely. If the grout is pumped too quickly, cracking of the slab may occur due to accumulation of the grout in one location.

The telephone survey conducted in this research and the communications during field visits indicate that TxDOT engineers have some concerns with regard to the use of slab jacking with conventional cement grouts. In general they are not satisfied with the degree of control that one has in the slab jacking process. They were also not satisfied with the time taken for the repair and the time taken before the bridge can be re-opened to traffic.

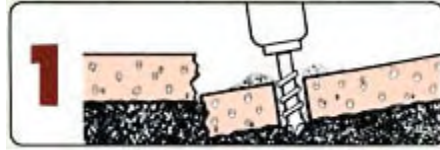

(a) Drilling 1-5/8 inch holes are drilled through the slab

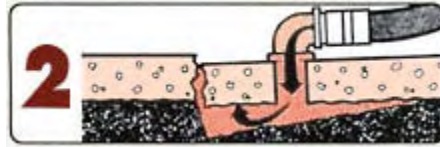

(b) Pumping grout mixture under the slab

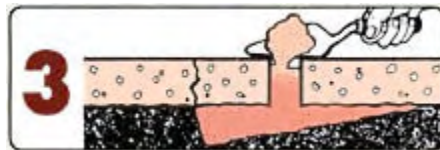

(c) Patching holes using a concrete mixture.

Figure 5.17 Steps Involved in Slab Jacking
(Courtesy of Concrete Slab Jacking, Inc., Maryland USA)

5.5.4 Slab Jacking Using Polyurethane Foam

Slab jacking using polyurethane is very similar to conventional slab jacking except that it uses a special proprietary process developed by URETEK, USA. Some TxDOT districts have already used this method in mitigating bridge approach/departure problems. Among the various TxDOT districts, the Houston District appears to have the most experience in using this technique. Their experience with the URETEK slab jacking process suggests that the process has a number of advantages over conventional slab jacking. According to TxDOT maintenance engineers, this process provides much better control and can be completed in a much shorter time. Consequently, interruption to traffic can be minimized when URETEK slab jacking is used. The primary drawback in this method is the cost of repair. URETEK generally determines project costs by applying a unit price per kilogram of injected material which is about \$20 per kilogram. The total costs of projects completed by TxDOT are significantly higher than those completed using conventional repair methods. Although the project costs are higher, the extra cost may be justified based on shorter time taken for project completion. This is particularly important when repairing bridges that carry heavy volumes of traffic. Additionally, the early performance data suggests that this repair technique provides a better quality job that requires less maintenance work in the future. A second concern arises from the fact that this proprietary material is relatively new in the market and therefore, there is no information on the long-term degradation of this product (polyurethane). Therefore, it may be

desirable to investigate the long-term performance of this material through a properly designed monitoring program.

Figure 5.18 shows URETEK polyurethane foam being injected into a grout hole during slab jacking.

5.5.5 Patching Approach Slabs

If a particular portion of the approach slab is badly damaged, then it will be necessary to remove and replace the unsound portion of the slab. This can be accomplished with a full depth patching of the slab. As a first step, the slab is saw cut through its entire depth for the full width of the lane. This procedure is done to separate the unsound concrete in the patching area from the adjacent sound concrete so that the intact slab is not damaged during the removal process. Whenever possible the deteriorated concrete must be removed by lifting it out. Lifting old concrete imparts no damage to the subbase and is usually faster and requires less labor than any method that breaks the concrete for removal. However, machine mounted removal equipment, such as slab breakers or hoe rams, may be used to remove the concrete in the patch area as long as the removal process does not damage the adjacent sound concrete. Full depth removal continues until sound concrete, sufficient to anchor dowel bars, is present. Any base or subbase that has been disturbed during the removal process is required to be recompacted.

5.5.5.1 Patching with In-Situ Concrete

Once the old, damaged concrete has been removed, replacement of the removed portion of the slab can be accomplished in two different ways. The first method is to use a new in-situ pour. The second is to use a precast panel. This section describes full-depth repair using an in-situ concrete patch. URETEK Precast repair is described in the Lufkin (LFK) portion of the report. (See Bridge 2, pages 45-46)

Full depth patches are required to have dowel bars installed in the adjoining concrete slab. Holes are drilled in the existing pavement to accept the dowel bars. Care should be taken when drilling the holes so that they are parallel with the edge and surface of the slab. The dowel bars are coated with a chemical anchoring system (epoxy), the holes are filled with this same material, and the dowel bars are inserted into the holes. The proper alignment of the dowel bars is required to be maintained until the anchoring material hardens. Concrete is then placed and consolidated by vibration. It is recommended that concrete for full depth patches may only be placed after 1:00 pm if the next day's forecasted ambient temperature is 70°F or greater. This time limitation allows the existing concrete slab to fully expand before placing the concrete. This reduces the risk of damage the expansion could cause to the curing patch. Sufficient curing time (between 15-30 hrs depending on the temperature) should be allowed before the repaired approach is opened to traffic.

5.5.5.2 Patching with Pre-cast Concrete Slab

A second alternative that is available is to replace the damaged concrete slab with a precast panel. Whenever a precast concrete panel is used for patching, the new slab



Figure 5.18 URETEK Slab Jacking Process

must be tied into the existing slab by providing appropriate positive mechanical interconnection across the joints. There are a number of ways this can be achieved.

(a) *Slot Stitching*: Slot stitching is considered to be an extension of the dowel bar retrofit technique. The procedure begins by cutting slots approximately perpendicular to the joint. The slots are cleaned out by removing loose concrete fragments from them. Next, deformed bars are inserted into slots and the slots backfilled with fast setting concrete. Figure 5.19 illustrates the slot stitching process for an existing slab.

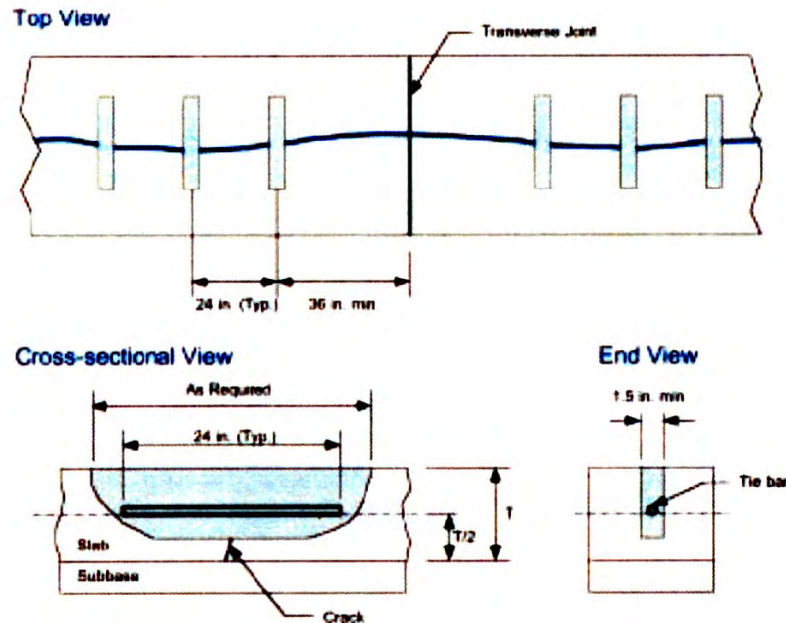

Figure 5.19 Slot-Stitching of a Concrete Slab Across a Crack

(b) *URETEK's Stitch-in-Time*: Uretek Stitch-in-Time technology is another technique that is available to restore load transfer to jointed concrete pavements. The procedure involves cutting a series of 0.5-in wide saw cuts across the joint and then inserting 0.25-in thick polymer composite strips into each slot. Then the inserts are bonded into place by filling the slots with sand and hybrid ultra-dense polymer. The bonding material has very fast curing characteristics and thus, the bridge can be opened to traffic almost immediately after the repair has been completed. Figure 5.20 through 5.22 show a bridge approach slab being repaired with a precast concrete slab and stitched into place using the URETEK Stitch-in-Time method

(c) *Cross-Stitching*: A third technique that can be used to provide load transfer across joints is called cross-stitching. Cross-stitching uses deformed tie bars inserted into holes drilled across a crack or joint at angles of 35-45 degrees. The steps involved in cross-stitching are as follows: First, holes are drilled at 24 to 36 inch spacings at an angle so



Figure 5.20 Precast Slab being Lowered into Place



Figure 5.21 Sawcut Prepared to Receive Polymer Insert



Figure 5.22 Precast Panel after the Repair has been Complete

that they intersect the crack or joint at about mid-depth. The angle of inclination of the hole will depend on the thickness of the slab. Then the holes are airblown to remove dust and debris. Next, epoxy is injected into the holes leaving some volume for the bars to occupy inside the holes. Finally, tiebars are inserted into the holes leaving about 1 inch from the top of the bars to the concrete surface. Figure 5.23 illustrates this process.

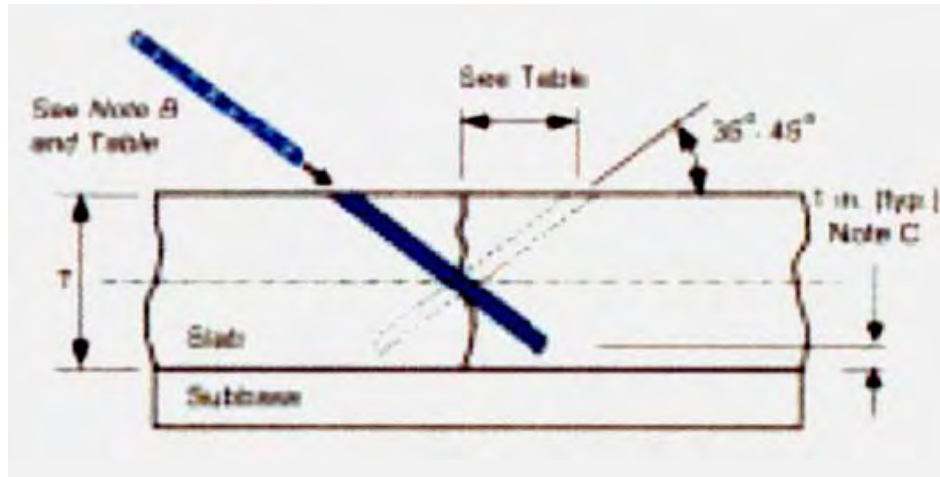

Figure 5.23- Cross-Stitching Across a Crack

5.5.6 Approach Reconstruction

If the bridge approach has suffered extensive damage then its rehabilitation may not be achieved economically with any of the bridge repair alternatives described above. In this case, reconstruction of the approach will be necessary. These projects will typically involve removal of either the entire approach slab or major portions of it. One major advantage in approach reconstruction is that it allows implementation of other remedial measures to address the “root causes” of the problem. Such remedial measures may include: (a) removal of weak embankment material and replacing it with non-erodible, stable material such as cement stabilized backfill or, (b) installation of a subsurface drainage system.

5.5.6.1 Use of Cement Stabilized Backfill

Many of the problems commonly encountered in bridge approaches may be overcome by using a wedge of cement stabilized material immediately behind the bridge abutment. Cement stabilized material offers a number of advantages over conventional backfill. First of all, cement stabilized sand backfill has better flowability and therefore, is capable of filling any small void spaces that may be present. Secondly, it does not require compaction to gain necessary strength and thus overcomes the difficulties associated with achieving adequate compaction behind the abutment. Once the cement stabilized material hardens, it will not be sensitive to moisture changes and will not erode. Therefore, the use of a cement stabilized sand (CSS) "wedge" in the zone behind the abutment is encouraged in the TxDOT bridge design manual. Figure 5.24 shows a bridge

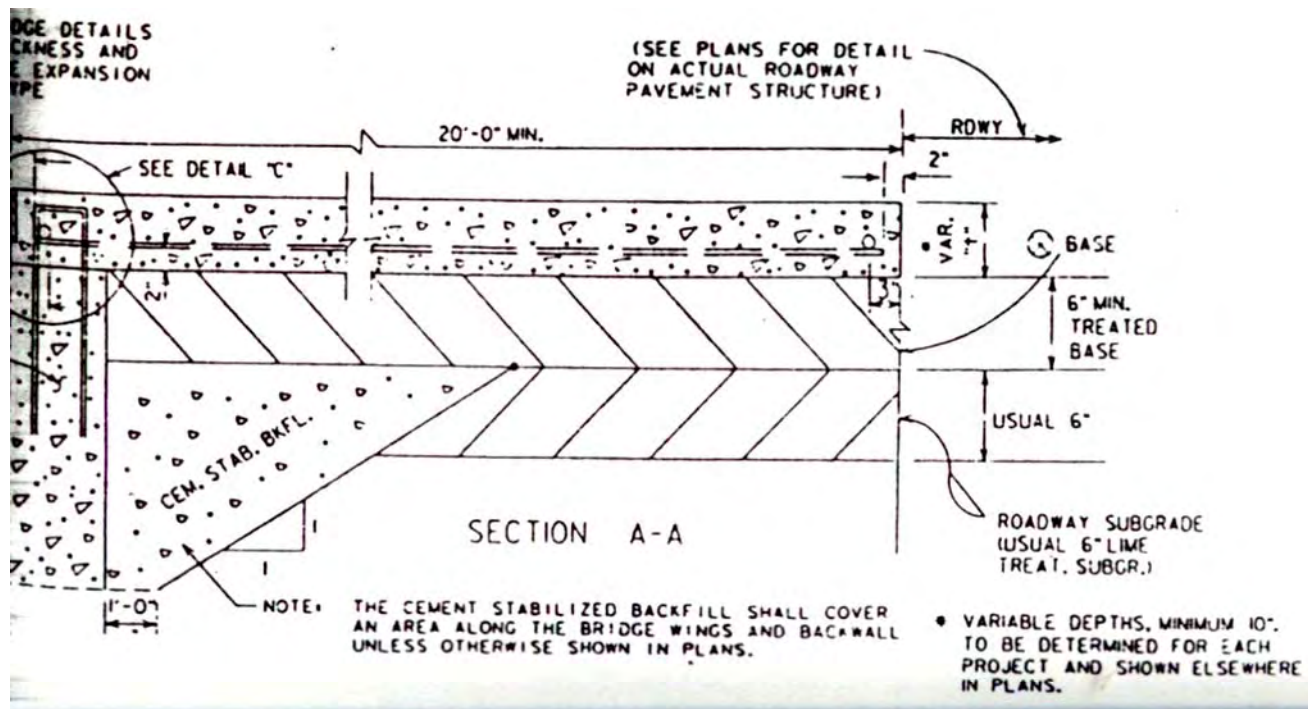

Figure 5.24 Bridge End Detail Showing Cement Stabilized Sand (CSS) Wedge Behind Abutment

approach design with a CSS wedge. In some districts, this has now become the standard practice. The performance of bridge approaches that have been constructed according to this design has been very good.

For the reasons given above, the option of using a CSS wedge behind the abutment should be given serious consideration in new bridge construction and approach reconstruction projects. As mentioned previously, CSS wedge has the potential to overcome many problems experienced at bridge approaches. However, it should be noted that this material does not have the capability to transmit water efficiently, and therefore, CSS will not function as a subdrain system. Therefore, water that enters the approach through joints and cracks in the approach slab and pavements may still cause damage in areas in which CSS material is not present.

5.5.6.2 Use of Subdrain (or Underdrain) System

In Texas, the use of a subdrain system underneath the bridge approach slab is not standard practice at the present time. However, in some TxDOT districts such as Houston, it was common practice many years ago (personal communications with Michael Alford, Director of Maintenance, Houston District, TxDOT). The subdrain system design used by the Houston District previously is shown in Figure 5.25. Other districts, such as Lufkin have also used subdrain systems for some of their bridges. Figure 5.26 shows a drainage detail that was once used in the ABL district (behind an abutment wall). It should be noted that this drainage system is not currently being used in the Abilene District. The purpose of the subdrain (or underdrain) is to collect water that leaks through cracks and joints in the pavement and the approach slab and carry it away from the bridge end so that it would not cause damage by soil erosion and subgrade saturation.

Providing a subdrain system underneath the approach slab and pavement is best accomplished during the initial construction of the bridge approach rather than during repair. Most of the repair strategies discussed in this section would not allow the installation of such a subdrain system. However, this would be possible in many approach reconstruction projects. A more complete collection of different subdrain system designs that may be considered is found in Appendix A.

There are two important points that must be considered when arriving at a decision with regard to the installation of a subdrain system. First, if it becomes necessary to use slab stabilization or slab jacking during future maintenance operations, the grout that is pumped will likely clog the subdrain and make it ineffective. Second, subdrain systems require regular maintenance to ensure that they function properly. Adequate cleanout features or access points should be provided during design and construction.

Relevant TxDOT specifications to the suggested repair methods have been attached in the Appendix E.

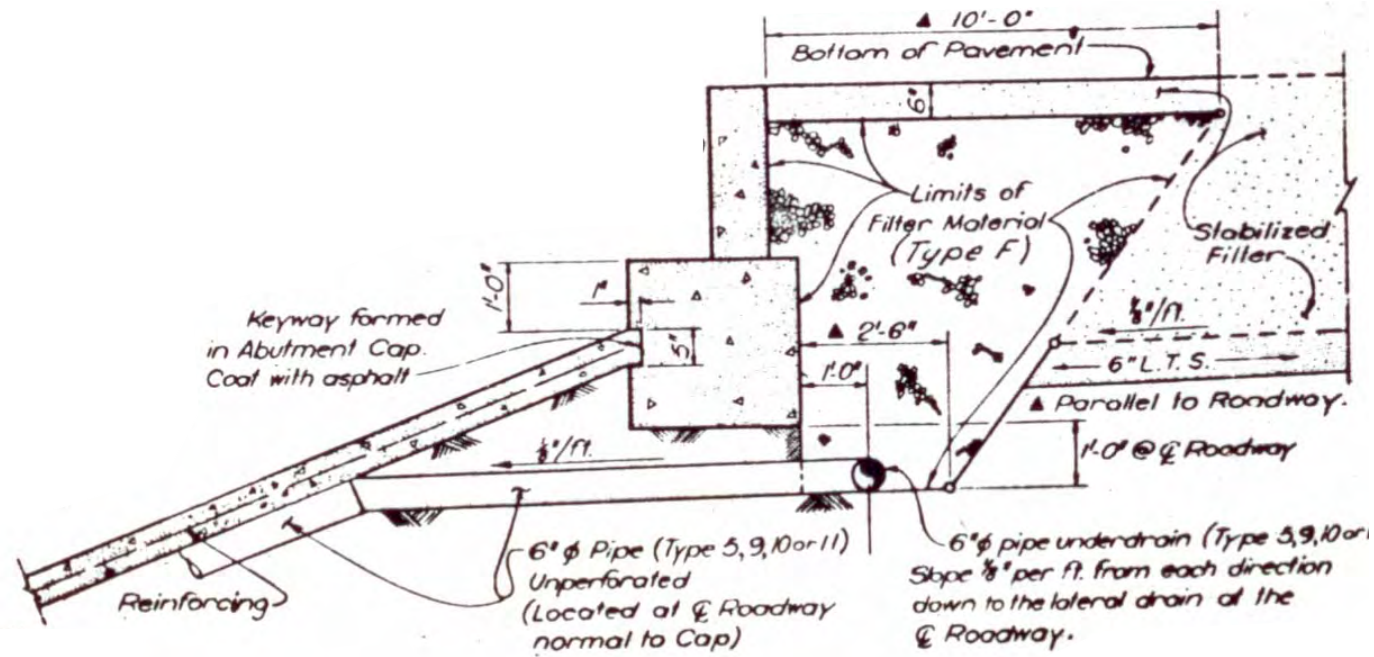
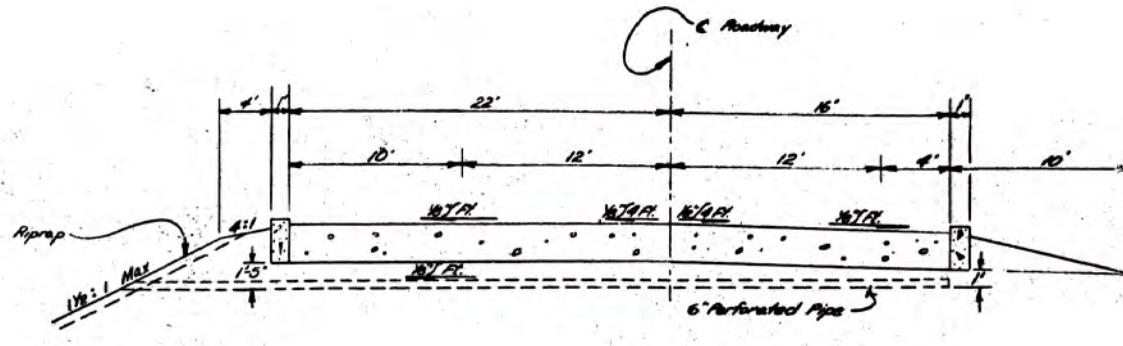
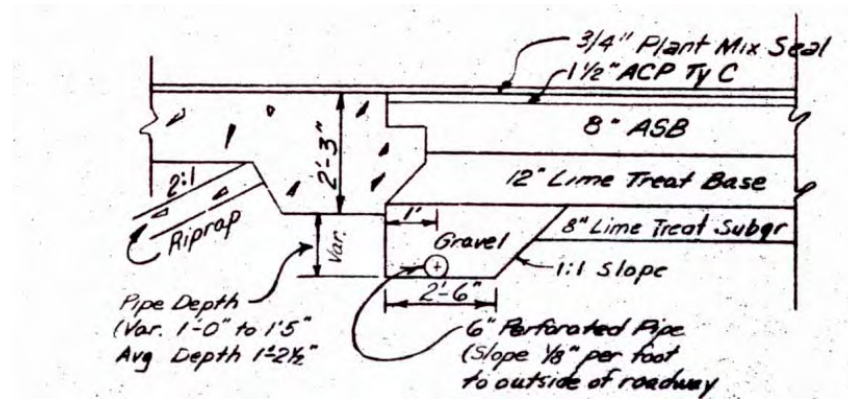

Figure 5.25 Bridge End Detail Showing Subdrain System Used in the Houston District



(a) Cross-section of Roadway at Bridge



(b) Section through Riprap and Abutment

Figure 5.26 Bridge End Detail Showing Subdrain System Previously Used in the Abilene District

Chapter 6

Conclusions and Recommendations

6.1 Conclusions

Water intrusion and approach slab settlement problems vary throughout the state of Texas. Some districts deem water intrusion to be a significant maintenance problem, while other districts do not. Many TxDOT engineers attribute water intrusion at bridge ends and subsequent settlement problems to a lack of proper compaction of fill material near abutments. Findings from this research study substantiate that the dominant source for water intrusion at bridge ends is surface water inflow through cracks and poorly sealed joints in the pavement surface. Wicking of water through capillary action can exacerbate water problems in embankments at bridge ends by increasing the degree of saturation of the fill material and inhibiting the flow of water through the fill material. Water movement near abutments, near wing walls, beneath approach slabs, or beneath riprap tends to erode fill material and can create large voids beneath the surface.

Bridge sites in four TxDOT districts were investigated for possible sources of water intrusion. One site, in the Abilene district, exhibits a continuing seepage problem indicative of water beneath the pavement surface. Researchers performed thorough field and laboratory investigations to determine the source of the water intrusion. The major source of the water intrusion was found to be inflow from surface water, although capillary action at the site keeps fill material in the embankment in a near saturated condition.

A site assessment procedure was developed and reported herein to help recognize in-the-field causes of water collection at bridge approaches. The procedure considers important factors that must be taken into consideration when developing a suitable strategy for repairing a damaged bridge approach.

A number of surface drainage and subsurface drainage systems have been employed in Texas, and several designs are presented in this report. It appears that the existing water seepage problem on the US 83 overpass of Antilley Road in Abilene can be repaired by installing an underdrain at the proper location beneath the roadway surface. A design previously used by the Tyler district is a viable candidate for use at the Abilene location.

A variety of repair procedures have been attempted by departments of transportation to fill voids and level pavement surfaces. Repair techniques vary from “leveling up” with hot mix asphaltic concrete to complete removal and replacement of bridge end features such as approach slabs, embankments, or riprap. The most successful method is a proprietary system named URETEK®. URETEK has been used successfully in 13 TxDOT districts. The URETEK® technique employs a polyurethane material pumped into voids beneath the surface. The process can be used to fill voids and even lift and level pavement slabs or riprap slabs.

An Item Description for URETEK is included in this research report.

6.2 Recommendations

Based upon the findings from the research study, the following items are recommended:

Adequate surface drainage should be provided to move water from the bridge deck through adequate channels to prevent water from intruding into the embankment fill material. Surface drainage system design should be consistent with local climatic conditions. The observations made in the research study suggest that standard drainage provisions may not be adequate in some parts of the state that receive heavy rainfall.

Joints in the bridge deck or pavement surface must be properly sealed. It is imperative that the joints be periodically maintained to remove debris and ensure proper sealing. Other preventive maintenance techniques that show considerable promise are: (a) slab stabilization (or undersealing) for controlling void development underneath the approach slab and concrete pavement and, (b) cross-stitching and slot stitching for controlling further development of any cracks that appear in the approach slab and concrete pavement.

Subsurface drainage should be installed to remove water that has entered into the fill material. Periodic inspection is required to maintain the subsurface drainage systems and remove any obstructions that might impede the free flow of water through the drainage system.

Geotextile fabric should be placed beneath joints and other locations beneath pavement surfaces or riprap to prevent the loss of material by erosion.

A detailed design of a repair and installation of an underdrain should be accomplished for the US 83 overpass of Antilley Road in Abilene. The underdrain design should be similar to the detail provided by the Tyler district.

An implementation project should be initiated to demonstrate the effectiveness of the repair and maintenance procedures recommended from the study. Several bridges with different approach designs should be selected, repaired as necessary, and monitored for five years to determine the effect of recommended maintenance practices on the decrease of water intrusion at bridge ends and resulting decrease in repair costs.

REFERENCES

1. TRB, NCHRP Synthesis of Highway Practice 234, "*Settlement of Bridge Approaches (The Bump at the End of the Bridge)*", Transportation Research Board, National Research Council, Washington D.C., 1997
2. TRB, NCHRP Synthesis of Highway Practice 239, "*Pavement Subsurface Drainage Systems*", Transportation Research Board, National Research Council, Washington D.C., 1997
3. Ha, H., Seo, J., Briaud, J.L., "*Investigation of Settlement at Bridge Approach Slab Expansion Joint*", TxDOT Project Report 0-4147, Texas Transportation Institute, 2002.
4. Horvarth, J. S., "*Integral Abutment Bridges: Problems and Innovative Solutions Using EPS Geof foam and other Geosynthetics*", Manhattan College Research Report No. CE/GE-00-2, 2002
5. "*Concrete Pavement Repair Manual*", American Concrete Pavement Association, 2003
6. "*Concrete Pavement Joint Sawing, Cleaning and Sealing*", Concrete Paving Workforce Reference No. 3, PCC Center, Iowa State University, 2004
7. Robertson, R., Olson, R., Milner, C., "*Edge Joint Sealing As a Preventive Maintenance Practice*", Minnesota Department of Transportation Internal Report, Presented at TRB 2000
8. Hall, K.T., Correa, C.E., "*Effects of Subsurface Drainage on Performance of Asphalt and Concrete Pavements*", NCHRP Report 499, TRB, Washington D.C., May 2003
9. Chou, E.Y., Fournier, L., Wielinski, J., Rao, C., Titus-Glover, L., "*Evaluation of Guidelines for Subgrade Treatments*", FHWA/OH-2005/003, 2005
10. DuBose, J.B., "*An Evaluation of IDOT's Current Underdrain Systems*", State of Illinois Department of Transportation, Division of Highways, Bureau of Materials and Physical Research, December, 1995
11. White, D.J., Sritharan, S., Suleiman, M., Mekkawy, M., Chetlur, S., "*Identification of the Best Practices for Design, Construction and Repair of Bridge Approaches*", Iowa DOT Project TR-481, Center for Transportation Research and Education, Iowa State University, January, 2005
12. Olson, R., Robertson, R., "*Edge-Joint Sealing as a Preventive Maintenance*", Minnesota Department of Transportation, August, 2003
13. Horvath, J.S., "*Integral-Abutment Bridges: A Complex Soil-Structure Interaction Challenge*", American Society of Civil Engineers Geo Institute, Geo-Trans 2004, Los Angeles, July 2004
14. TRB, NCHRP Synthesis of Highway Practice 285, "*Maintenance of Highway Edge Drains*", Transportation Research Board, National Research Council, Washington D.C., 2000
15. Baumgardner, R.H., "*Maintenance of Highway Edge Drains*", February 2002
16. Kuennen, T., "*Making Edge Drains Work*", Better Roads, January 2003
17. Eacker, M.J., Bennett, A.R., "*Evaluation of Various Concrete Pavement Joint Sealants*", Research Report No. R-1376, Michigan Department of Transportation, May 2000

18. Donahue, J.P., “*Void Detection with Falling Weight Deflectometer*”, Final Report R/99-044, Missouri Department of Transportation Research, Development and Technology, January 2004
19. Startk, T.D., Arellano, D., Horvath, J.S., Leshchinsky, D., “*Guideline and Recommended Standard for Geofam Applications in Highway Embankments*”, NCHRP Report No. 529, TRB, Washington D.C., 2004
20. “*Slab Impulse Response (Slab IR)*”, Olson Engineering Inc.
21. Soltesz, S., “*Injected Polyurethane Slab Jacking*”, Interim Report SPR 306-261, Oregon Department of Transportation, September 2000
22. Rutkowski, T.S., Shoher, S.F., Schmeidlin, R., “*Performance Evaluation of Drained Pavement Structures*”, Research Project No. WI 87-05, Wisconsin Department of Transportation, December 1998
23. Hall, K.T., Correa, C.E., Carpenter, S.H., Elliot, R.P., “*Rehabilitation Strategies for Highway Pavements*”, NCHRP Web Document 35 (Project C1-38): Contractor’s Final Report, May 2001
24. “*Materials and Procedures for Repair of Joint Seals in Portland Cement Concrete Pavements: Manual of Practice*”, FHWA Report No. FHWA-RD-99-146, Strategic Highway Research Program (SHRP), National Research Council, Federal Highway Administration
25. “*Resealing Concrete Pavement Joints*”, Publication No. FHWA-RD-99-137
26. Koerner, R.M., “*Subsurface Drainage*”, A2K06: Committee on Subsurface Drainage
27. Kantor, Jonathan, “*The URETEK Method Drives More Effective Road and Highway Maintenance*”, Columbia Daily Tribune, July 2004
28. Gaspard, K., Morvant, M., “*Assessment of the URETEK Process on Continuously Reinforced Concrete Pavement, Jointed Concrete Pavement and Bridge Approach Slabs*”, Technical Assistance Report No. 03-2TA, Louisiana Transportation Research Center, December 2004
29. “*The URETEK Deep Injection Process (UDI) for Roadways and Building Structures*”, (www.worldofuretek.com)
30. French, J.W., McKeel, W.T., “*An Evaluation of Bridge Deck Joint Sealing Systems in Virginia*”, Technical Assistance Report, VTRC 03-TAR7, Virginia Transportation Research Council, June 2003
31. Hoppe, E.J., “*Guidelines for the Use, Design and Construction of Bridge Approach Slabs*”, VTRC 00-R4, Virginia Transportation Research Council, November 1999

APPENDIX A

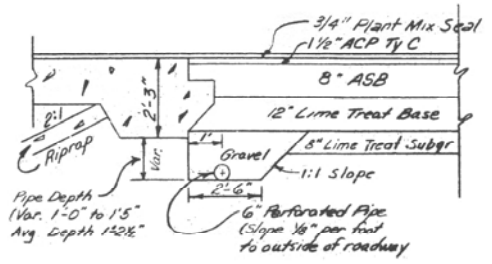
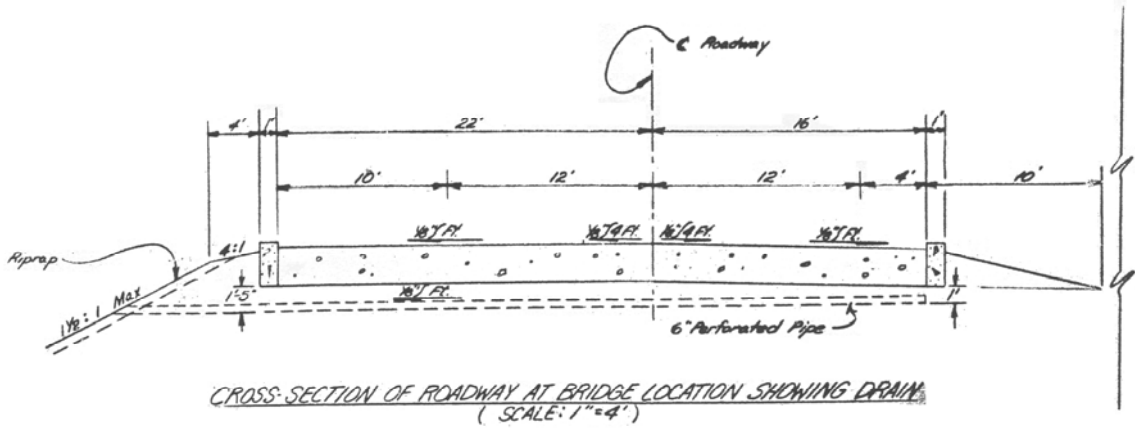

FIAB21 Quantities Pipe Underdrains

Item 556	Each Bridge End	Total
Pipe Underdrains (Type 10)	48 LF	192 LF
Underdrain Excavation	7.5 CY	30 CY
Filter Material (Type F)	6.5 CY	26 CY

Filter Material will consist of coarse aggregate for Item 421 and two sacks cement per cubic yard.

ROADWAY DETAILS AT BRIDGE ENDS

FIG. NO.	STATE	PROJECT NO.
6	TEXAS	120-2 (A) 11
TOTAL	COUNTY	SHEET NO.
CB		56

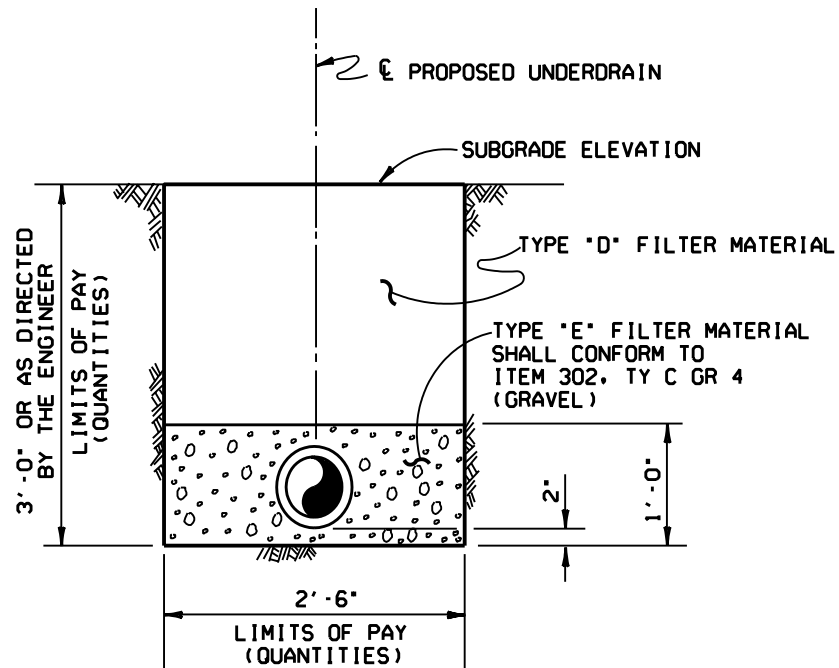

UNDERDRAIN DETAIL

TYPICAL SECTION

(NOT TO SCALE)

NOTE: LOCATION OF UNDERDRAINS MAY BE VARIED AS JOB
 CONDITIONS INDICATE OR AS DIRECTED BY THE
 ENGINEER.
 LATERALS SHALL HAVE A MINIMUM GRADE OF 0.50%.

(NO SCALE)

APPENDIX B

Date: _____

Person conducting survey: _____

Person/District answering survey: _____

QUESTIONNAIRE

A. Purpose

The purpose of this survey is to collect the information needed for a research study that we are conducting for TxDOT. The research study is related to the settlement of approach embankments near bridge ends. A number of previous research studies have investigated this problem. However, it is important to note that this research study is different from previous studies from the following viewpoints.

- (a) First, this research study deals with repair and maintenance of existing bridge approaches to remedy settlement problems; In other words, this study does not deal with new construction
- (b) This study specifically focuses on the intrusion of water into the embankment fill at bridge ends and the resulting loss of material from underneath approach slabs

B. Information Requested

We would appreciate your input on the following.

1. Is settlement at bridge ends a significant maintenance problem in your district? Does your district spend a significant amount of money and/or manpower on repair of bridge approaches that have settled?
2. During such repairs, maintenance crews in some districts have observed that the subbase/base material underneath the approach slab was extremely wet. In some cases, there was evidence of loss (or erosion) of material. Is this a common observation in your district?
3. If saturated base/subbase material is commonly found at bridge ends during repairs, do you have any idea as to where the water would have come from (e.g. runoff from the bridge that enters through cracks/joints, moisture pulled up from a shallow groundwater table by wick action etc.)?
4. Do you use a specific "surface water drainage system" design (or designs) to divert bridge runoff (i.e. surface water) away from bridge ends so that the approach embankment is protected from erosion?
5. Do you use a specific "subsurface drainage system design" (or designs) to drain water that may enter subsoil through joints and cracks in the approach slab?
6. What specific bridge approach designs do you use in your district? (with approach slab/without approach slab, type of terminal joint: wide flange, lug

- anchor etc.). Are some of these designs more (or less) prone to the settlement problem than others?
7. What methods have been used in your district to repair settlement at bridge ends (e.g. use of cement stabilized fill behind the bridge abutment, mud jacking, overlay etc)? How do these methods compare in terms of cost, speed of construction, and reliability?
 8. As a part of this study we intend to select a few bridges for detailed study. For this purpose we would like to identify a few bridges that have had a history of frequent and persistent settlement problems. Do you have any bridges that we could include in the detailed study?
 9. Are there other individuals in your district who may be able to provide us with useful information on this matter?

**Responses to Questionnaire
8/29/2005**

District	1.	2.	3.	4.	5.	6.	7.	8.	9.
Abilene	Yes	Yes	Both surface water intrusion and wicking.	Use TxDOT standard	Yes. Have used a "French" drain design.	Yes	HMA overlay	Yes	Chad Carter
Amarillo	No. Not much money. One bridge many years ago before responder was in the district	Has not observed such a moisture problem. Aware of one in Borden County on US 180 (Abilene district)	Has not observed	Do not have such systems. Mentioned "popcorn" system used in Abilene to drain out sides and front.	No	Use approach slabs. No bridges without approach slab.	One-time use of a "French" drain. Has no personal experience.	No bridges to include.	Kenneth Petr and Henry Course.
Atlanta	Settlement is a moderate problem. Some cases are no trouble, some cases must be dealt with.	Notice it quite a bit. Yes, extremely wet. Yes, have lost material. Yes, it is a common problem.	Majority is runoff. No doubt that they have failed joint seals. Wave action at lakes erodes fill under rip-rap. Specify rock rip-rip, 10 inch with six in bed for streams. Pump grout into voids.	Generally wrap rip-rap around to end of approach slab on roadway side. Use flume to take water from roadway down edge of rip-rap. Will send me a detail.	No systems. Would have to encounter some water at the abutment or in the fill material.	Always use an approach slab with lug anchor. Will send me a detail.	Once or twice (5 or 6 years ago) specified cement stabilized backfill at edge. Dug trench at backwall then filled with cement stabilized backfill. Not a flowable fill, little moisture content. Will send me detail. Have used some mudjacking, successful, but it	Have a couple of bridges as candidates. US 59 at Big and Little Cypress Creek bridges. US 259 at Sulphur River in Bowie. Settlement two years after	Represents all. Willing to help with IPR.

							is a temporary fix. most of time. Use asphalt level-up because of reliability and cost. Used URETEK on concrete pavement, not on approach slab. Costly to remove approach slab.	construction. Neither have cement stabilized backfill. Would not expect settlement if they had cement stabilized backfill. Let a one-time retrofit a month ago. Just gotten aggressive with joint cleaning and bridge maintenance.	
Austin	Not a significant problem, and not a significant amount.	It has not been a common observation. It has been observed on at least one occasion.	The saturated base was believed to be pulling/wicking moisture from below.	Most rural construction uses concrete trough, most urban construction uses inlets and conduit in the bridge deck and approach roadways.	Weep holes are used on poured concrete aprons of header banks, MSE walled approaches are allowed to drain between panels.	The Austin District has constructed bridges with approach slabs and without (flexible pavement), and has principally used the wide flange terminal joint for the past 15 years, there is at least one application of lug anchor	The most common method is to use a finely graded pre-mix material to level-up the settlement (flexible pavement approaches). Some bridges have been overlayed (not typically performed due to bridge rail height issues). Concrete approach slabs,	No	No

						system. Some settlement can be observed in every style of approach. Settlement is generally believed to be that cause of poor consolidation of embankment during construction and/or migration of material.	wide flange, and lug anchor terminal joints have been raised by pressure injection of expanding polymer material (recent application with good success).		
Beaumont	Big problem. Construction issue, not maintenance. Money, no. Manpower, yes. Lack of compaction during construction. Lack strategy. Two issues: (1) water; (2) settlement not long (two years) after construction.	Yes. Problem in northern part of district. Water moves fast and rip rap is no far enough around the ends of the bridges.	Overpasses – water from the top (no wicking, 15 ft high). At grade – both directions (from stream underneath)	Use standard design. One case used asphalt curb under guard rail. Details from bridge division.	No Subsurface drainage not help because of rapid flow.	Use concrete approach slab on all bridges. All are prone to settlement (lack of compaction). Slab behind not settling.	Use level-up material. URETEK used on less than 10 bridges.	Yes. Will help select bridge, welcomed visit.	No
Brownwood	No – we have had minor settlement at	No – have not removed any approach	Not applicable	No	No	No approach slab. We have some older	No applicable	No	No

	many bridge ends that was leveled by normal blade level up operations	slabs to see what was underneath				bridges constructed in 1940 – 1960 with approach slabs.			
Bryan	Not a significant problem and have not spent much money on repairs. Many older bridges have steep side slopes and no approach slabs. Newer bridges have flatter slopes and approach slabs, and have fewer problems. Rivers erode slopes from underneath.	Yes. Have seen, but is not a major problem. Older designs have high slopes on narrow roads with poor drainage.	Water wicking at one location, Hwy 21 in Burleson County near district office. Close water table near a railroad bridge that created vibration.	No, just use basic approach slab with no gutter or drain. Did use T501 type barriers (open drain). Now use T-2 or T-3 rail with big openings.	Has seen, but only on a few bridges with problems. Recently using non-eroding materials beneath approach slab (4-in thick).	All pavements are flexible type. Use a concrete approach slab (13-in thick) with steel or armor joint on bridge side and pavement against slab on roadway side. Experience poor bonding and joint seal problems with water intrusion in joints.	Have little experience with repairs. Once used foam between cracks to fill voids but not to level slab.	Have a few. Ten bridges have problems. Some suffer erosion rather than water intrusion. Water goes in joint with wing wall design. One design has approach slab continuous with wing wall.	No.
Childress	Settlement in past years (say before 1995) was a problem in our district, and maintenance forces had to	Our maintenance forces primarily made up for the settlement by placing premix or	I feel that water intruded from the joint between the approach slab and wingwalls. If this joint was not properly sealed and	No. We simply use the standard shoulder drain.	One of the first new designs we used was a perforated pvc pipe underdrain. This pipe was located	In the mid 1990's we modified the statewide approach slab standard to extend over the wingwalls. This design	Most settlement I'm aware of has occurred slowly, therefore premix or hotmix was used to smooth the pavement roughness around the bridge ends. If	I am not aware of any bridge end settlement our maintenance folks are struggling with right	Jimmy Bridges is our district BRINSAP coordinator and has a wealth of knowledge about our district's bridges.

	<p>contend with it a lot. During the mid 1990's our district began implementing new designs to try and alleviate future settlement on new bridge replacement projects. And for the most part, this has been successful.</p>	<p>hotmix at the bridge ends, or approach slab ends, when settlement was detected, thus confirming the loss of some material. And wet subgrade and/or base was simply a given.</p>	<p>maintained, then water had a direct path to the base and subgrade below.</p>		<p>behind the backwall and backfilled with cement stabilized gravel. Along with this design we began lime stabilizing all bridge approaches. This design was used for a few years and then quit. I haven't found a good answer as to why we quit, but we did. We now place flowable fill behind the backwall and wingwalls to give the approach slab a better support directly</p>	<p>eliminated the joint between the wingwalls and approach slab. We still use this design today on all our new bridge projects.</p>	<p>our maintenance forces do get into the base or subgrade to make repairs, they normally use cement to stabilize the wet material. If loss of material has occurred, such as under some concrete riprap, we will use flowable fill to fill the void.</p>	<p>now.</p>	
--	---	--	---	--	--	---	---	-------------	--

					around the bridge.				
Corpus Christi	Yes. Spent money and manpower on repairs, but do not have an accurate account on the costs.	Yes, have encountered wet base material. Noticeable movement of retaining walls, and loss of materials at abutment.	With no approach slab, flex base extends to abutment. Lack of compaction causes dip which accumulates water. (Additional comments)	Some bridges have a curb system, but majority do not have a surface water drainage system.	Not applicable	So not use approach slabs. Believes that use of approach slabs would eliminate this problem.	Adding hot mix or cold mix is the fastest way to correct problem. Cement stabilized fill takes the longest. Suggests cement treat base with hot mix overlay or remove base material and add asphalt stabilized base with final hot mix overlay.	Contact Anthony Villarreal.	Anthony Villarreal
Dallas	Settlement is a problem at older bridges that do not have approach slabs. At stream crossings water boils up behind the back wall and erodes the soil. The combination of swelling clay and slabs over compacted clay causes a	I-30 over FM 740 overpass – perched water table; excavation; pump water out every day. Introduce water at remote locations; water flows underneath pavement.		Use surface flumes. Have erosion on either side of these flumes. Commonplace for slides to occur.			Replace native soil with select material to a 3-ft depth. Use lower permeability material; granular soil. URETEK gives a more permanent repair. Used to be a proprietary product, but now have some competition. 7 – 10 years experience. Have also used conventional concrete jacking.		

	rising up of approach slabs.						Used asphalt level up. Cement stabilized layers quite common.		
El Paso	Yes. Spent some money, not sure significant. Hard to repair on IH (overnight) use overlays. Problem, construction sequencing or details. Need impervious material on approach slab. Even new ones have dip or matching problems.	See voids at ends of approach slab near retaining walls. Yes, moisture present (of course). Intrusion through cracks. Have used polymer seals, work for 6 mo. – 1 year.	From joints. No wicking in El Paso. Groundwater too deep.	Not really. Have T 501 railing, put flume to take to side of riprap. No standard design in district, use state standard, does not hold water, erosion at top of pan.	No, not that he knows of.	Stopped using approach slab. Re-started with Austin recommendation. Fewer joints eliminates problems. Thinks that they use anchor lugs.	Cement slurry used at Lee Trevino ant IH-10, successful. Had to close for three days. Able to because of frontage road. Not common, just attempted, worked well. Major effort widening bridge.	Could take off shoulder. Interstate most problems, hard to shut down. Like to be a part of the study. Interested, talk further, like to participate.	Ray Lopez (915) 790-4377. Tim Twomey.
Fort Worth	All applies. Huge problem with approach slabs. Lack of compaction near abutment wall, voids develop (up to two feet	Yes. I-35. Found water throughout roadway. Installing underdrains. TxDOT has spec. Will send spec # to me.	Need flumes.	Construction might have specs. Bob Julian (817 370-6515) or Ray Buzalski. Use down spouts to columns. Ray Buzalski sent details to	Twenty years ago used a vertical system that a supplier donated using filter material. Picked up water, in six months the	All bridges being built have approach slabs. All have the same design.	See previous notes. Have used URETEK, continues to settle (no fault of URETEK). Cement stabilized backfill also settles. Lack of inspection	Could provide. I-35 & I-30 downtown. Fairly new bridge.	

	depth). Lot of erosion under rip-rap. Concerned that mower will cause collapse. Level-up and evens up with time. Pavement less than two years old, guard rail post holes not compacted properly, eroded a void for ¼ mile under asphalt pavement. Used URETEK to repair. Water should be moved in concrete flume, but they do not use.			Nash by e-mail message.	system was stopped up. Nothing successful.		is a problem.		
Houston	Yes, settlement is a significant maintenance problem. Settlement is	Observes standing water during repair. Problem also noted at box	Construction inspection and management also changed in early 90's. Combination of	Struggle with designing gutter drains. Only standard is under the rip rap design.	In the past underdrain systems were used. When underdrain	Concrete pavement. Went exclusively to wide-flange beam.	Have used a lot of URETEK. Rip rap, approach slab and fill material. Dig out up to two feet to get to		

	<p>an issue. Bad ride is as much an issue as settlement. Previously shot grades from bridge, now because of speed of construction, create grade problems. Four or five overpasses on 290 have settlement problems. Other overpasses in district have settlement problems.</p>	<p>culvert on departure side of embankment. Put in underdrain system under one system. After a half-inch rain, the underdrain ran water for a week.</p>	<p>runoff or wicking. Water flowing through drain slots sometimes shoots past the drip line by several feet, saturates header embankment. Water table is near 20 feet in some locations.</p>	<p>Usually added after construction (failures). Drains collect about 25% of runoff (apron too small) and creates erosion at edge of gutter. Monothrie beam curb blocks drain.</p>	<p>systems were removed from designs, water intrusion problems started. A strip drain was used successfully on one project. ACTIV. CONTECH does a lot of drainage.</p>		<p>stable materials. Used conventional mudjacking (soil-cement mix). Have own rig. Problems with contact on lift. Quality depends on experience of operator. Mudjacking is a multistage operation. Fluid pressures can blow out rip rap. Have used URETEK for 15 years. Corpus Christi has used a lot of URETEK (big project on 77 near Robstown. Can no longer sole source, sole source as sub-contractor. Repaired 10 bridges in five days using URETEK.</p>		
Laredo	<p>Settlement where clays are used. Not as much a problem where select fill materials</p>	<p>Not had to remove and replace any bridge approach pavements to date.</p>	<p>Ongoing problem in La Salle County – concrete rip rap collapsed due to subsurface seepage.</p>	<p>Use TxDOT standard surface drainage details</p>	<p>No</p>	<p>Approaches on about half of our bridges. Most approaches have been constructed in the last 5 years.</p>	<p>Removed and replaced selected sections of pavement. Replace with cement stabilized backfill (caliche</p>	<p>Bridge rip rap repair on SH97 in La Salle County</p>	<p>Greg Howard, Jose de la Paz</p>

	are used. HMAC overlay used to smooth transition.						and cement) or limestone rock asphalt base material.		
Lubbock	Not many problems with approach slabs. Most problems with compaction during construction. Problems with water getting under rip rap and washing out soil at the toe and creating voids under the rip rap.	Not a common observation.	Not from wicking up. Some districts use curbs to channel water (not Lubbock). Have shallow ditches, don't intercept water well. Water misses the ditch. Some talk of using curbs again.	Some districts use curbs to channel water (not Lubbock). Some talk of using curbs again.	Use plastic pipe below rip rap that collects water and carries down.		Used foam jacking approximately 5 years ago. Can see dip today. Better but not completely away. Use backfill with "flowable backfill." Local concrete producers, comes in mix trucks.	I-27 at 4 th Street.	John Rantz Randy Woods in Plainview
Lufkin	Yes	Yes	Predominantly from surface water, but subsurface possible.	Use TxDOT standard	No	Yes	URETEK, mudjacking and complete replacement. URETEK expensive but effective. Mudjacking is less appealing.	Yes	Nancy Smith
Odessa	Very minor	One or two bridges. Header band (not at	Always from top. Groundwater is very deep and	No. Most bridge drain at end of bridge. Some curb	No	Use approach slab on everything. Use wide flange. No	Only two. Replaced approach slab. Placed 1 – 2 feet	Not enough rain.	No.

		stream bed) built from sandy loam, rain off bridges, enters between bridge and approach slabs (or on sides, approach and retaining walls) carried out fine materials. Replaced slab one time.	the ditches drain well.	and gutter using standard drawings for wrap around (header bank). Sent drawings to TechMRT		lug anchors. Sent drawings to TechMRT.	of cement stabilized material under slab.		
Paris	PJ								
Pharr	Yes. Do not spend as much as we should. Continuously patching and leveling.	No moisture, but loss of fines. ??? out on edges, see erosion. Surface water running off deck, out guard rail. Have rip rap there, gets beneath rip rap. Shoulder drains an					Patching and leveling. Some mud jacking. Used URETEK on a concrete approach slab. Milled off overlay to see when level. Worked well (3 years ago) US 83 in front of District. Jackson & ??? overpass (westbound). (Get-in and get-out.		

		issue. Thrie-beam, need concrete curb beneath. First 18'-9 takes water farther away from bridge end.							
San Angelo	Significant problem but not because of number of incidents	Not as much water as loss of material. Observed capillary action twice in career (FM 1929 Lake Ivy, Concho county) SH 70 in Coke County at Oak Creek Reservoir) Continuing problem, level-up every two years.	Water from top. Two from capillary action. Moisture beneath approach slab. Guess 20 feet. Fixed now.	No. Just curb and gutter along edge of road.	No.	Approach slab butts against abutment and butts again at roadway. Approximately 20-ft length.	Took out approach slab. Cement stabilized (to solid material) subgrade approximately two feet (Lake Ivy) Blade level up hot mix cold laid.	None that comes to mind. Just normal consolidation. Not a severe problem. Construction problem at header. Compaction needed at abutment. Walter thinks cement stabilizer flex base area of abutment 20 feet wide x length. Natural ground below.	Not anyone else.
San Antonio	Not significant on the north side. Might be significant	Do not use approach slabs anymore.	Settlement is attributed to poor compaction of backfill rather	No drain scuppers provided. Concrete plume.			URETEK. Maintenance contracts. Proprietary/Patent. Not anyone else		

	on south side. Pavement problems. Abutments move. Wing walls shift. Rip-rap cracks & shifts.		than to intrusion of water. Poor compaction – low density – allows water to seep in – settle – repeated repairs. Recent wet weather (wet year). South side/Pleasanton area. Uses sugar sand soil for backfill. Rip-rap does not have weep holes. Saturated sand backfill is pumped out of pavement joints. Embankments with high PI clay. Swelling causes rip rap to crack. Embankment will shift downhill. Sand wash out through joints in rip-rap.	Guard rail, water directed longer distance before it can get to the plume. Joint where asphalt meets bridge. Overlay and seal up to the bridge. Mound of HMAC/seal coat rock sitting under guardrail.			bid. 3 or 4 projects. Contact area engineers. \$350,000 - \$400,000 tearing flex base put back gravel & black????		
Tyler	Rip rap problems.	Rip rap.	Wicking action under approach	Does not deal with surface	Under drain.	Use approach slabs most of the	Flowable fill. Not a repair.	Mining company	No

	Water from edge of rip rap, cavity under stream bed.		slab. Put in underdrain system – French drain. Bridge for mining company so the company funded.	drainage.		time. Some do not use approach slabs. Area Engineer decides.		bridge.	Will send typical section.
Waco	More problems with culverts (seasonal). Proposed cement stabilized base backfill at bridge ends and under approach slab.	Not encountered water. Side slop 3/1 optimum moisture content. Moisture builds up and causes slide, then slope too much. No bump problem.					Used URETEK while in Dallas, has not used in Waco. Some leveling of approaches. Spread thin with inspectors (more jobs than inspectors).		
Wichita Falls	Yes; less than one percent of the district maintenance budget.	Seldom see wet base/subbase materials beneath pavements that are removed and replaced. (Additional comments)	Primarily caused by surface water drainage through pavement and bridge structure joints and cracks. (Additional comments)	Typically allow surface water to drop off bridge structure. Block openings over underlying roads or railroad. (Additional comments)	No	Not discussed.	HMAC overlay to repair settlement. Leveled by normal blade operations.	Not aware of any.	Allan Moore, Ralph Self Pavement Engineer/Bridge Engineer
Yoakum	Spend some time on	Have found wet soils.	Suspect joints are open at	Have started putting in	Have never incorporated	Did use approach slabs.	Have used URETEK for	Have a couple of	Glenn Dvorak

	<p>problem, leveling. It is not an overriding problem. Some locations require maintenance once per year. Believes problems are related to construction problems. Have high PI materials.</p>		<p>wing wall. A couple of coastal counties might experience wicking action.</p>	<p>down drains at the end of the wing walls to prevent water from intruding behind the walls. Not sure if the detail came from Austin.</p>	<p>subsurface drains. Rip rap finally washes out. Have some bridges with wash outs. .Some (rip rap joints separate and water flushes the joints.</p>	<p>Not sure of current designs. Will go to Design and get back with me. Have never used downspouts. Thinks that subsurface drains are a good idea.</p>	<p>level up and were happy with it. Used on a couple of projects to repair existing pavements (3-4 years ago, 6-7 years ago). Also dig out and put stabilized material (cement stabilized, 2 – 3 feet deep, 25 – 30 feet out). Used mudjacking 15 years ago and had to redo.</p>	<p>bridges. Foot or so from backwall lacks compaction, water enters. Initiated hand compaction and have no problems with those bridges (2 – 3 years).</p>	
--	--	--	---	--	--	--	--	---	--

Questions:

1. Is settlement at bridge ends a significant maintenance problem in your district? Does your district spend a significant amount of money and/or manpower on repair of bridge approaches that have settled?
2. During such repairs, maintenance crews in some districts have observed that the subbase/base material underneath the approach slab was extremely wet. In some cases, there was evidence of loss (or erosion) of material. Is this a common observation in your district?
3. If saturated base/subbase material is commonly found at bridge ends during repairs, do you have any idea as to where the water would have come from (e.g. runoff from the bridge that enters through cracks/joints, moisture pulled up from a shallow groundwater table by wick action etc.)?
4. Do you use a specific "surface water drainage system" design (or designs) to divert bridge runoff (i.e. surface water) away from bridge ends so that the approach embankment is protected from erosion?
5. Do you use a specific "subsurface drainage system design" (or designs) to drain water that may enter subsoil through joints and cracks in the approach slab?
6. What specific bridge approach designs do you use in your district? (with approach slab/without approach slab, type of terminal joint: wide flange, lug anchor etc.) Are some of these designs more (or less) prone to the settlement problem than others?
7. What methods have been used in your district to repair settlement at bridge ends (e.g. use of cement stabilized fill behind the bridge abutment, mud jacking, overlay etc.)? How do these methods compare in terms of cost, speed of construction, and reliability?
8. As a part of this study we intend to select a few bridges for detailed study. For this purpose we would like to identify a few bridges that have had a history of frequent and persistent settlement problems. Do you have any bridges that we could include in the detailed study?
9. Are there other individuals in your district who may be able to provide us with useful information on this matter?

APPENDIX C

SPECIAL SPECIFICATION**3128****Raising and/or Undersealing Concrete Slabs**

- 1. Description.** This Item shall govern for raising and/or undersealing of concrete slabs at locations shown on the plans and/or designated by the Engineer. This work shall include drilling injection holes, injection of material, checking elevations to control lift of pavement, cleanup, filling joints and/or cracks with epoxy grout, if not filled by a polyurethane product, and other related work.
- 2. Material.** The material used for raising and/or undersealing concrete slabs shall be a high density polyurethane material, such as Uretek 486 or equivalent, as approved by the Engineer. Epoxy material described herein shall be in accordance with Department Material Specification D-9-6100 (DMS-6100).
- 3. Equipment.** The following list of lifting and undersealing equipment shall be considered the minimum amount of equipment to perform the work.
 - (1) A drill capable of 1/2 inch or 5/8 inch diameter holes.
 - (2) A pumping unit capable of injecting the polyurethane between concrete and subbase and capable of controlling the rate of rise of the pavement.
- 4. Construction Methods.**
 - (1) **Preparation.** The Contractor shall prepare a profile of each area to determine the extent of the concrete pavement that requires adjustment(raising).
 - (2) **Drilling.** The injection holes shall be drilled in the following manner. A series of 1/2 inch or 5/8 inch holes shall be drilled at about three (3) to six (6) foot intervals through the concrete in the area to be raised. The exact location and spacing of the holes shall be determined by the Contractor.

The high density polyurethane formulation is injected under the slab. The amount of rise shall be controlled by the pumping unit and by regulating the rate of injection of the high density polyurethane material. When the nozzle is removed from the hole, any excessive polyurethane material shall be removed from the area and the hole sealed.
 - (3) **Grade Control.** The finished concrete slab should conform to the grades and cross-section of the slab prior to settlement. Prior to beginning grade adjustments to the slab, the Contractor shall submit to the Engineer, for approval, a detail of the area to be treated with the final proposed grades.

Final elevations shall be within 1/4 inch of the elevations proposed by the profile. The Engineer, at the Department's expense, may check the treated area to confirm that the pavement has been realigned properly to facilitate drainage.

The Contractor shall be responsible for any pavement blowouts, excessive lifting or uneven pavement that is the result of the raising of the pavement. The damaged area shall be fixed or repaired, at the Contractor's expense, to the satisfaction of the Engineer.

- (4) **Set-Time.** The high density polyurethane formulation used shall set and obtain 90 percent of its ultimate compressive strength within 15 minutes of injection. The compressive strength shall be shown on the plans, as recommended by the manufacturer.
5. **Measurement.** The high density polyurethane (hdp) formulation will be measured by the pound. This will include furnishing and injecting the hdp material.
6. **Payment.** The work performed and materials furnished in accordance with this Item and measured as provided under "Measurement" will be paid for at the unit price bid for "Raising and/or Undersealing Concrete Slabs". This price shall be full compensation for all work covered by this Item, including furnishing and injecting material, all labor, materials, tools and equipment necessary to complete the work.

APPENDIX D

**US Highway 83 over Antilley Road, Abilene, TX
Moisture Content Profile with Depth for B3**

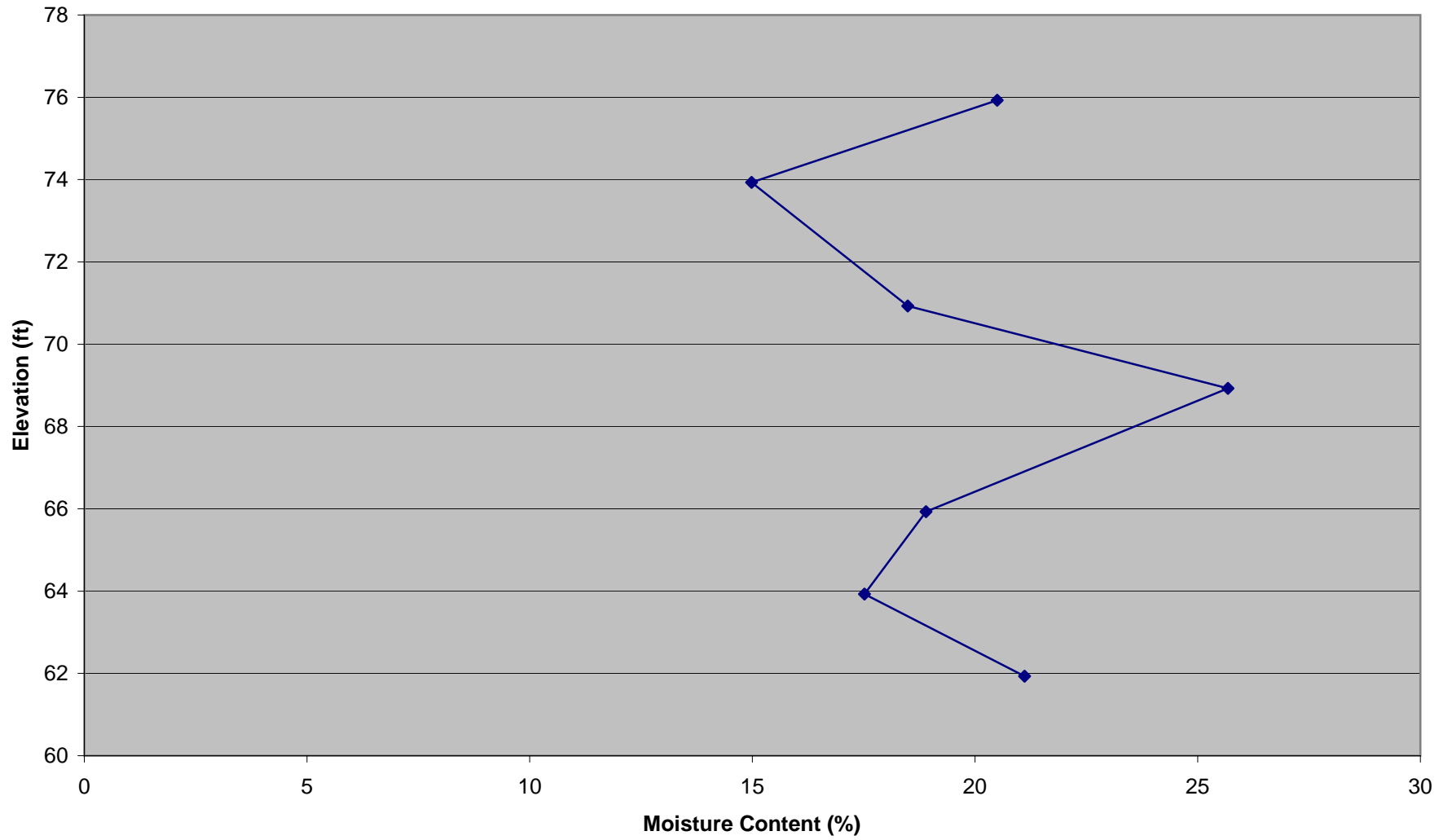

**US Highway 83 over Antilley Road, Abilene, TX
Moisture Content Profile for B2**

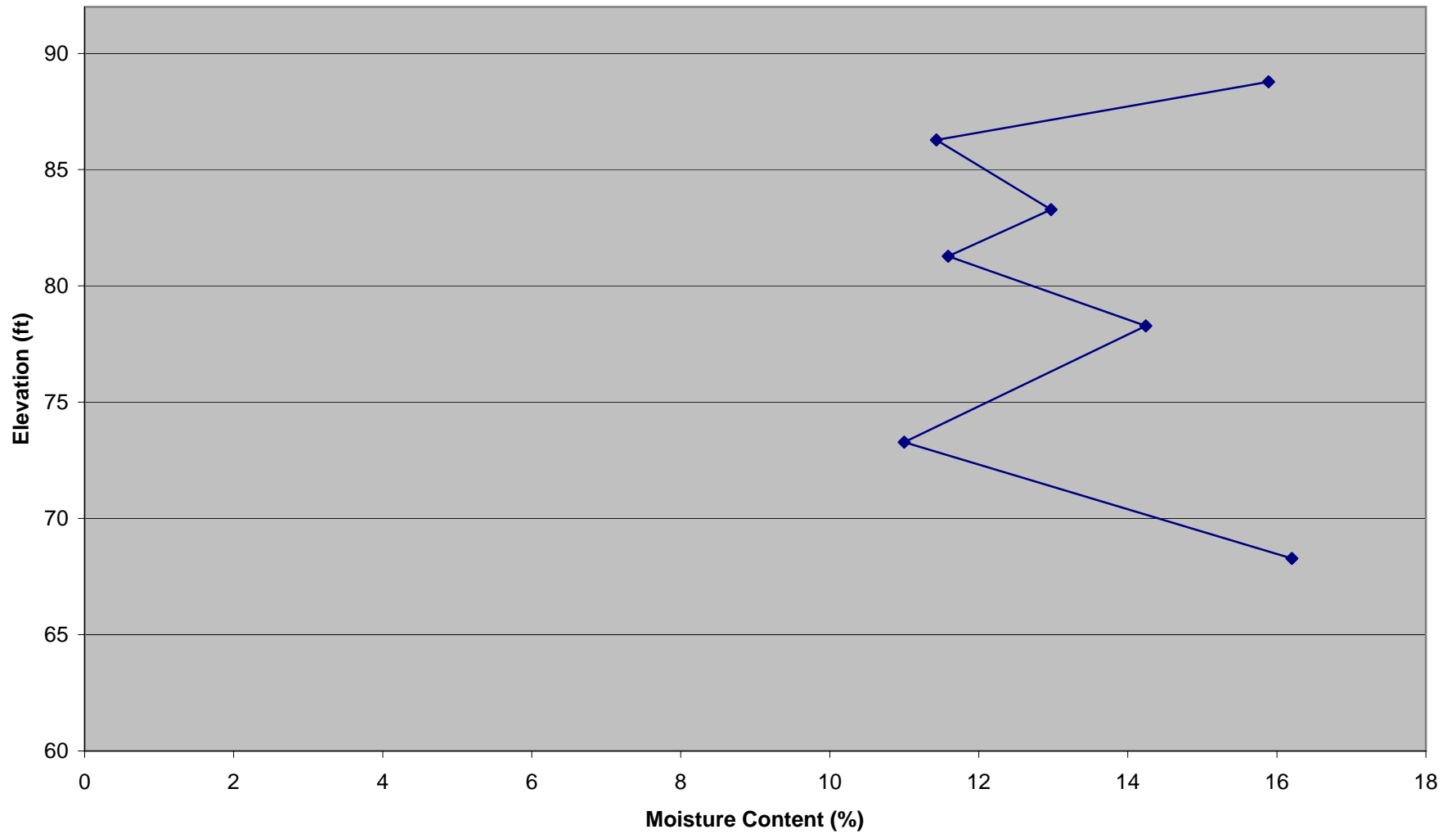

**US Highway 83 over Antilley Road, Abilene, TX
Moisture Content Profile with Depth for B3**

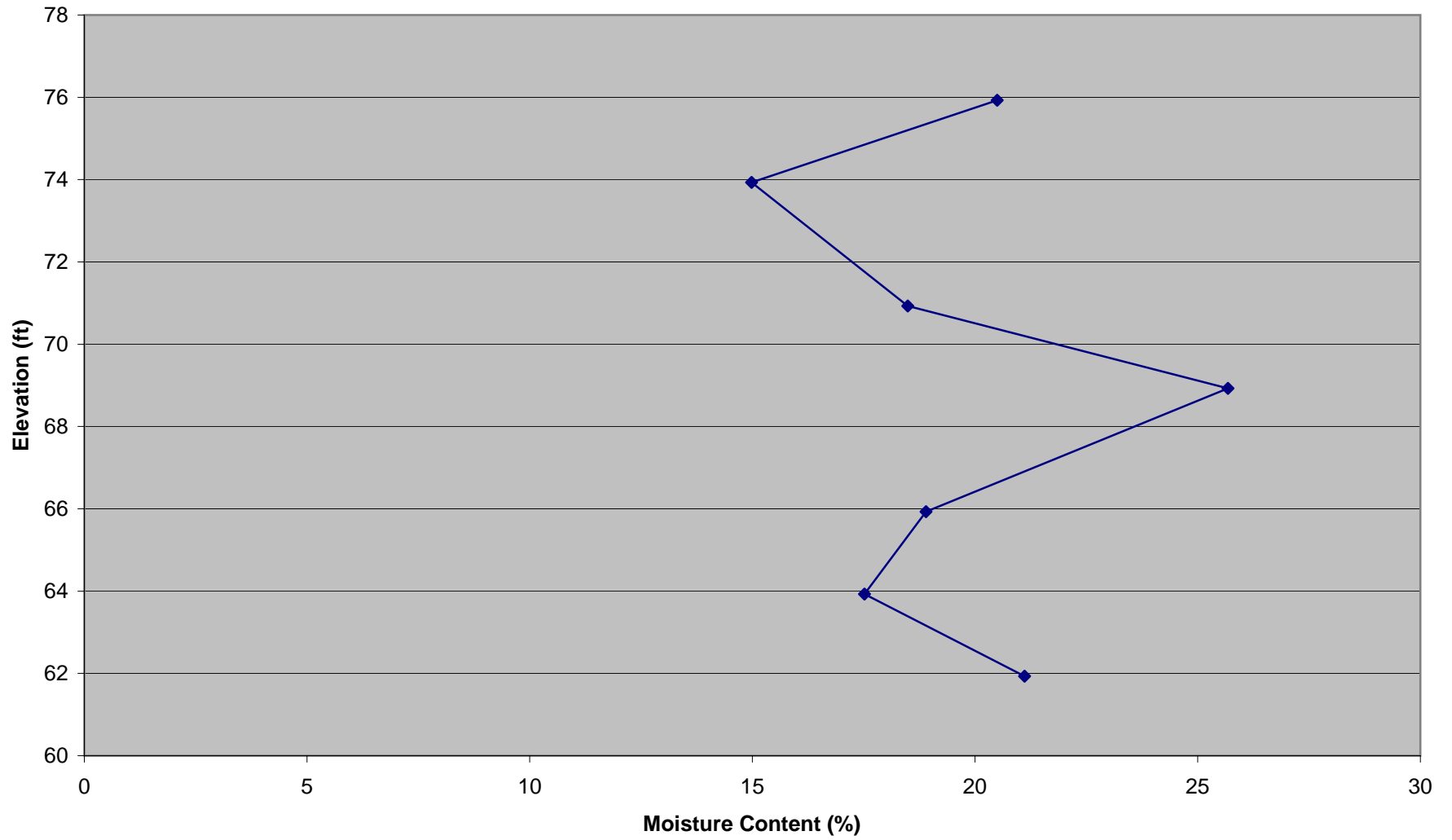

Soil Testing TxDOT Project 0-5096

Moisture Content Determination

Boring No.: 1

Location: US-83 over Antilley Road, Abilene, TX

Sample No.: 1

Date of Boring: 18th July 2005

Depth: 5'-7'

Description of sample:

Tested By: Debakanta Mishra

Determination No.	1	2	3
Container No.	1	2	3
Mass of Container, M_c (g)	32.38	31.13	31.78
Mass of Container + Wet Specimen, M_{cws} (g)	58.14	59.06	62.77
Mass of Container + OD Specimen, M_{cs} (g)	54.5	55.33	58.48
Mass of Water, M_w (g)	3.64	3.73	4.29
Mass of Solid Particles, M_s (g)	22.12	24.2	26.7
Moisture Content, w (%)	16.46	15.41	16.07
Average Moisture Content (%)	15.98		

Boring No.: 1

Location: US-83 over Antilley Road, Abilene, TX

Sample No.: 2

Date of Boring: 18th July 2005

Depth: 10'-12'

Description of sample:

Tested By: Debakanta Mishra

Determination No.	1	2	3
Container No.	6	7	8
Mass of Container, M_c (g)	31.95	32.68	30.5
Mass of Container + Wet Specimen, M_{cws} (g)	56.93	60.43	62.91
Mass of Container + OD Specimen, M_{cs} (g)	53.63	57.33	58.81
Mass of Water, M_w (g)	3.3	3.1	4.1
Mass of Solid Particles, M_s (g)	21.68	24.65	28.31
Moisture Content, w (%)	15.22	12.58	14.48
Average Moisture Content (%)	14.09		

Boring No.: 1

Location: US-83 over Antilley Road, Abilene, TX

Sample No.: 3

Date of Boring: 18th July 2005

Depth: 15'-16'

Description of sample:

Tested By: Debakanta Mishra

Determination No.	1	2	3
Container No.	4	5	9
Mass of Container, M_c (g)	31.45	31.07	32.04
Mass of Container + Wet Specimen, M_{cws} (g)	54.74	62.25	60.96
Mass of Container + OD Specimen, M_{cs} (g)	51.97	58.52	57.32
Mass of Water, M_w (g)	2.77	3.73	3.64
Mass of Solid Particles, M_s (g)	20.52	27.45	25.28
Moisture Content, w (%)	13.50	13.59	14.40
Average Moisture Content (%)	13.83		

Boring No.: 1

Location: US-83 over Antilley Road, Abilene, TX

Sample No.: 4

Date of Boring: 18th July 2005

Depth: 21'-23'

Description of sample:

Tested By: Debakanta Mishra

Determination No.	1	2	3
Container No.	10	11	12
Mass of Container, M_c (g)	31.63	30.87	21.7
Mass of Container + Wet Specimen, M_{cws} (g)	62.61	69.28	59.13
Mass of Container + OD Specimen, M_{cs} (g)	59.33	64.91	55.15
Mass of Water, M_w (g)	3.28	4.37	3.98
Mass of Solid Particles, M_s (g)	27.7	34.04	33.45
Moisture Content, w (%)	11.84	12.84	11.90
Average Moisture Content (%)	12.19		

Boring No.: 1

Location: US-83 over Antilley Road, Abilene, TX

Sample No.: 5

Date of Boring: 18th July 2005

Depth: 26'-28'

Description of sample: This side looks like native material. Field marked 26 (may be wrong)

Tested By: Debakanta Mishra

Determination No.	1	2	3
Container No.	16	17	18
Mass of Container, M_c (g)	31.14	18.83	21.87
Mass of Container + Wet Specimen, M_{cws} (g)	59.64	53.23	54.57
Mass of Container + OD Specimen, M_{cs} (g)	54.72	47.65	48.72
Mass of Water, M_w (g)	4.92	5.58	5.85
Mass of Solid Particles, M_s (g)	23.58	28.82	26.85
Moisture Content, w (%)	20.87	19.36	21.79
Average Moisture Content (%)	20.67		

Boring No.: 1

Location: US-83 over Antilley Road, Abilene, TX

Sample No.: 6

Date of Boring: 18th July 2005

Depth: 26'-28'

Description of sample: This side looks like fill. Significantly moist. Field marked 28' (may be wrong)

Tested By: Debakanta Mishra

Determination No.	1	2	3
Container No.	19	20	21
Mass of Container, M_c (g)	18.93	18.87	18.81
Mass of Container + Wet Specimen, M_{cws} (g)	49.18	43.53	56.95
Mass of Container + OD Specimen, M_{cs} (g)	43.77	38.46	49.22
Mass of Water, M_w (g)	5.41	5.07	7.73
Mass of Solid Particles, M_s (g)	24.84	19.59	30.41
Moisture Content, w (%)	21.78	25.88	25.42
Average Moisture Content (%)	24.36		

Boring No.: 1

Location: US-83 over Antilley Road, Abilene, TX

Sample No.: 7

Date of Boring: 18th July 2005

Depth: 31'-32"

Description of sample: From the moist side. Other side looked like trash from drilling mud

Tested By: Debakanta Mishra

Determination No.	1	2	3
Container No.	22	23	24
Mass of Container, M_c (g)	18.48	18.92	18.81
Mass of Container + Wet Specimen, M_{cws} (g)	64.3	55.21	49.92
Mass of Container + OD Specimen, M_{cs} (g)	55.21	48.93	44.24
Mass of Water, M_w (g)	9.09	6.28	5.68
Mass of Solid Particles, M_s (g)	36.73	30.01	25.43
Moisture Content, w (%)	24.75	20.93	22.34
Average Moisture Content (%)	22.67		

Boring No.: 1

Location: US-83 over Antilley Road, Abilene, TX

Sample No.: 8

Date of Boring: 18th July 2005

Depth: 37'-38.5'

Description of sample: Very Hard. Perfect shape. Reddish Clay type

Tested By: Debakanta Mishra

Determination No.	1	2	3
Container No.	13	14	15
Mass of Container, M_c (g)	30.58	22	25.12
Mass of Container + Wet Specimen, M_{cws} (g)	70.61	79.87	60.21
Mass of Container + OD Specimen, M_{cs} (g)	65.72	72.69	55.72
Mass of Water, M_w (g)	4.89	7.18	4.49
Mass of Solid Particles, M_s (g)	35.14	50.69	30.6
Moisture Content, w (%)	13.92	14.16	14.67
Average Moisture Content (%)	14.25		

Boring No.: 2

Location: US-83 over Antilley Road, Abilene, TX

Sample No.: 1

Date of Boring: 18th July 2005

Depth: 2.5'-4.5'

Description of sample:

Tested By: Debakanta Mishra

Determination No.	1	2	3
Container No.	1	2	3
Mass of Container, M_c (g)	32.52	31.51	32.11
Mass of Container + Wet Specimen, M_{cws} (g)	60.32	61.66	62.66
Mass of Container + OD Specimen, M_{cs} (g)	56.52	57.65	58.33
Mass of Water, M_w (g)	3.8	4.01	4.33
Mass of Solid Particles, M_s (g)	24	26.14	26.22
Moisture Content, w (%)	15.83	15.34	16.51
Average Moisture Content (%)	15.90		

Boring No.: 2

Location: US-83 over Antilley Road, Abilene, TX

Sample No.: 2

Date of Boring: 18th July 2005

Depth: 5'-7'

Description of sample:

Tested By: Debakanta Mishra

Determination No.	1	2	3
Container No.	4	5	6
Mass of Container, M_c (g)	31.8	31.47	32.28
Mass of Container + Wet Specimen, M_{cws} (g)	67.47	61.55	67.31
Mass of Container + OD Specimen, M_{cs} (g)	63.89	58.27	63.87
Mass of Water, M_w (g)	3.58	3.28	3.44
Mass of Solid Particles, M_s (g)	32.09	26.8	31.59
Moisture Content, w (%)	11.16	12.24	10.89
Average Moisture Content (%)	11.43		

Boring No.: 2

Location: US-83 over Antilley Road, Abilene, TX

Sample No.: 3

Date of Boring: 18th July 2005

Depth: 8'-9.5'

Description of sample:

Tested By: Debakanta Mishra

Determination No.	1	2	3
Container No.	7	8	9
Mass of Container, M_c (g)	25.43	30.88	32.34
Mass of Container + Wet Specimen, M_{cws} (g)	54.02	58.24	59.86
Mass of Container + OD Specimen, M_{cs} (g)	50.78	55.12	56.64
Mass of Water, M_w (g)	3.24	3.12	3.22
Mass of Solid Particles, M_s (g)	25.35	24.24	24.3
Moisture Content, w (%)	12.78	12.87	13.25
Average Moisture Content (%)	12.97		

Boring No.: 2

Location: US-83 over Antilley Road, Abilene, TX

Sample No.: 4

Date of Boring: 18th July 2005

Depth: 10'-12'

Description of sample:

Tested By: Debakanta Mishra

Determination No.	1	2	3
Container No.	10	11	12
Mass of Container, M_c (g)	31.94	31.06	22.09
Mass of Container + Wet Specimen, M_{cws} (g)	55.04	67.43	55.52
Mass of Container + OD Specimen, M_{cs} (g)	52.2	63.45	52.91
Mass of Water, M_w (g)	2.84	3.98	2.61
Mass of Solid Particles, M_s (g)	20.26	32.39	30.82
Moisture Content, w (%)	14.02	12.29	8.47
Average Moisture Content (%)	11.59		

Boring No.: 2

Location: US-83 over Antilley Road, Abilene, TX

Sample No.: 5

Date of Boring: 18th July 2005

Depth: 13'-14.5

Description of sample:

Tested By: Debakanta Mishra

Determination No.	1	2	3
Container No.	13	14	15
Mass of Container, M_c (g)	31	22.44	33
Mass of Container + Wet Specimen, M_{cws} (g)	58.51	54.07	53.14
Mass of Container + OD Specimen, M_{cs} (g)	54.99	50.09	50.72
Mass of Water, M_w (g)	3.52	3.98	2.42
Mass of Solid Particles, M_s (g)	23.99	27.65	17.72
Moisture Content, w (%)	14.67	14.39	13.66
Average Moisture Content (%)	14.24		

Boring No.: 2

Location: US-83 over Antilley Road, Abilene, TX

Sample No.: 6

Date of Boring: 18th July 2005

Depth: 18'-20'

Description of sample:

Tested By: Debakanta Mishra

Determination No.	1	2	3
Container No.	16	17	18
Mass of Container, M_c (g)	31.16	19.1	22.16
Mass of Container + Wet Specimen, M_{cws} (g)	52.38	41.46	44.8
Mass of Container + OD Specimen, M_{cs} (g)	50.15	39.16	42.45
Mass of Water, M_w (g)	2.23	2.3	2.35
Mass of Solid Particles, M_s (g)	18.99	20.06	20.29
Moisture Content, w (%)	11.74	11.47	11.58
Average Moisture Content (%)	11.60		

Boring No.: 2

Location: US-83 over Antilley Road, Abilene, TX

Sample No.: 7

Date of Boring: 18th July 2005

Depth: 18'-20'

Description of sample:

Tested By: Debakanta Mishra

Determination No.	1	2	3
Container No.	19	20	21
Mass of Container, M_c (g)	19.13	19.22	19.16
Mass of Container + Wet Specimen, M_{cws} (g)	44.48	45.96	50.29
Mass of Container + OD Specimen, M_{cs} (g)	42.1	43.32	47.2
Mass of Water, M_w (g)	2.38	2.64	3.09
Mass of Solid Particles, M_s (g)	22.97	24.1	28.04
Moisture Content, w (%)	10.36	10.95	11.02
Average Moisture Content (%)	10.78		

Boring No.: 2

Location: US-83 over Antilley Road, Abilene, TX

Sample No.: 8

Date of Boring: 18th July 2005

Depth: 23'-25'

Description of sample:

Tested By: Debakanta Mishra

Determination No.	1	2	3
Container No.	4	5	6
Mass of Container, M_c (g)	31.8	31.47	32.28
Mass of Container + Wet Specimen, M_{cws} (g)	76.08	83.33	71.14
Mass of Container + OD Specimen, M_{cs} (g)	69.7	76.48	65.56
Mass of Water, M_w (g)	6.38	6.85	5.58
Mass of Solid Particles, M_s (g)	37.9	45.01	33.28
Moisture Content, w (%)	16.83	15.22	16.77
Average Moisture Content (%)	16.27		

Boring No.: 2

Location: US-83 over Antilley Road, Abilene, TX

Sample No.: 9

Date of Boring: 18th July 2005

Depth: 23'-25'

Description of sample:

Tested By: Debakanta Mishra

Determination No.	1	2	3
Container No.	16	17	18
Mass of Container, M_c (g)	31.16	19.06	22.16
Mass of Container + Wet Specimen, M_{cws} (g)	61.05	54.04	47.8
Mass of Container + OD Specimen, M_{cs} (g)	56.95	49.15	44.23
Mass of Water, M_w (g)	4.1	4.89	3.57
Mass of Solid Particles, M_s (g)	25.79	30.09	22.07
Moisture Content, w (%)	15.90	16.25	16.18
Average Moisture Content (%)	16.11		

Boring No.: 3

Location: US-83 over Antilley Road, Abilene, TX

Sample No.: 1

Date of Boring: 18th July 2005

Depth: 3'-5'

Description of sample:

Tested By: Debakanta Mishra

Determination No.	1	2	3
Container No.	1	2	3
Mass of Container, M_c (g)	32.52	31.51	32.11
Mass of Container + Wet Specimen, M_{cws} (g)	64.83	53.43	55.27
Mass of Container + OD Specimen, M_{cs} (g)	59.04	50.01	51.1
Mass of Water, M_w (g)	5.79	3.42	4.17
Mass of Solid Particles, M_s (g)	26.52	18.5	18.99
Moisture Content, w (%)	21.83	18.49	21.96
Average Moisture Content (%)	20.76		

Boring No.: 3

Location: US-83 over Antilley Road, Abilene, TX

Sample No.: 2

Date of Boring: 18th July 2005

Depth: 3'-5'

Description of sample:

Tested By: Debakanta Mishra

Determination No.	1	2	3
Container No.	7	8	9
Mass of Container, M_c (g)	25.43	30.88	32.3
Mass of Container + Wet Specimen, M_{cws} (g)	59.34	71.41	54.97
Mass of Container + OD Specimen, M_{cs} (g)	53.46	64.44	51.35
Mass of Water, M_w (g)	5.88	6.97	3.62
Mass of Solid Particles, M_s (g)	28.03	33.56	19.05
Moisture Content, w (%)	20.98	20.77	19.00
Average Moisture Content (%)	20.25		

Boring No.: 3

Location: US-83 over Antilley Road, Abilene, TX

Sample No.: 3

Date of Boring: 18th July 2005

Depth: 5'-7'

Description of sample:

Tested By: Debakanta Mishra

Determination No.	1	2	3
Container No.	10	11	12
Mass of Container, M_c (g)	31.94	31.06	22.09
Mass of Container + Wet Specimen, M_{cws} (g)	72.31	63.51	58.87
Mass of Container + OD Specimen, M_{cs} (g)	67.23	59.18	54.03
Mass of Water, M_w (g)	5.08	4.33	4.84
Mass of Solid Particles, M_s (g)	35.29	28.12	31.94
Moisture Content, w (%)	14.40	15.40	15.15
Average Moisture Content (%)	14.98		

Boring No.: 3

Location: US-83 over Antilley Road, Abilene, TX

Sample No.: 4

Date of Boring: 18th July 2005

Depth: 8'-9.5'

Description of sample:

Tested By: Debakanta Mishra

Determination No.	1	2	3
Container No.	13	14	15
Mass of Container, M_c (g)	31	22.44	33
Mass of Container + Wet Specimen, M_{cws} (g)	70.04	57.9	71.25
Mass of Container + OD Specimen, M_{cs} (g)	63.81	52.57	65.2
Mass of Water, M_w (g)	6.23	5.33	6.05
Mass of Solid Particles, M_s (g)	32.81	30.13	32.2
Moisture Content, w (%)	18.99	17.69	18.79
Average Moisture Content (%)	18.49		

Boring No.: 3

Location: US-83 over Antilley Road, Abilene, TX

Sample No.: 5

Date of Boring: 18th July 2005

Depth: 10'-12'

Description of sample:

Tested By: Debakanta Mishra

Determination No.	1	2	3
Container No.	19	20	21
Mass of Container, M_c (g)	19.13	19.22	19.16
Mass of Container + Wet Specimen, M_{cws} (g)	44.15	42.79	42.03
Mass of Container + OD Specimen, M_{cs} (g)	39	38.08	37.29
Mass of Water, M_w (g)	5.15	4.71	4.74
Mass of Solid Particles, M_s (g)	19.87	18.86	18.13
Moisture Content, w (%)	25.92	24.97	26.14
Average Moisture Content (%)	25.68		

Boring No.: 3

Location: US-83 over Antilley Road, Abilene, TX

Sample No.: 6

Date of Boring: 18th July 2005

Depth: 13'-15'

Description of sample:

Tested By: Debakanta Mishra

Determination No.	1	2	3
Container No.	1	2	3
Mass of Container, M_c (g)	32.52	31.51	32.11
Mass of Container + Wet Specimen, M_{cws} (g)	62.24	58.06	60.7
Mass of Container + OD Specimen, M_{cs} (g)	57.67	53.79	56.06
Mass of Water, M_w (g)	4.57	4.27	4.64
Mass of Solid Particles, M_s (g)	25.15	22.28	23.95
Moisture Content, w (%)	18.17	19.17	19.37
Average Moisture Content (%)	18.90		

Boring No.: 3

Location: US-83 over Antilley Road, Abilene, TX

Sample No.: 7

Date of Boring: 18th July 2005

Depth: 15'-17'

Description of sample:

Tested By: Debakanta Mishra

Determination No.	1	2	3
Container No.	4	5	6
Mass of Container, M_c (g)	31.8	31.47	32.28
Mass of Container + Wet Specimen, M_{cws} (g)	56.62	55.87	58.92
Mass of Container + OD Specimen, M_{cs} (g)	52.92	52.41	54.76
Mass of Water, M_w (g)	3.7	3.46	4.16
Mass of Solid Particles, M_s (g)	21.12	20.94	22.48
Moisture Content, w (%)	17.52	16.52	18.51
Average Moisture Content (%)	17.52		

Boring No.: 3

Location: US-83 over Antilley Road, Abilene, TX

Sample No.: 8

Date of Boring: 18th July 2005

Depth: 17'-18.5'

Description of sample:

Tested By: Debakanta Mishra

Determination No.	1	2	3
Container No.	7	8	9
Mass of Container, M_c (g)	25.43	30.88	32.34
Mass of Container + Wet Specimen, M_{cws} (g)	49.37	60.41	64.76
Mass of Container + OD Specimen, M_{cs} (g)	45.29	55.24	59.01
Mass of Water, M_w (g)	4.08	5.17	5.75
Mass of Solid Particles, M_s (g)	19.86	24.36	26.67
Moisture Content, w (%)	20.54	21.22	21.56
Average Moisture Content (%)	21.11		

Soil Testing TxDOT Project 0-5096

Field Density Determination

Boring No.: 1

Location: US-83 over Antilley Road, Abilene, TX

Tested By: Debakanta Mishra

Date of Boring: 18th July 2005

Sample Depth	Height of cylindrical specimen (in)			Mean Height (in)	Diameter of Cylindrical Specimen (in)			Mean Diameter (in)	Volume (in ³)	Weight (g)	Field Density (pcf)
5'-7'	1.523	1.54	1.561	1.54	2.99	2.98	2.98	2.98	10.78	389.23	137.62
10'-12'	1.427	1.41	1.53	1.45	3.00	2.97	2.98	2.98	10.15	357.37	134.10
15'-16'	1.4215	1.442	1.4035	1.42	3.0195	2.9265	3.0395	3.00	10.02	363.02	138.02
21'-23'	1.639	1.649	1.651	1.65	2.972	2.9935	2.974	2.98	11.48	415.23	137.80
26'-28'	1.098	1.15	1.2235	1.16	3.0295	2.997	3.013	3.01	8.25	258.6	119.41
31'-32'	Density Measurement not possible. Sample falling apart										
37'-38.5'	3.563	3.615	3.6175	3.60	3.0155	3.023	2.9715	3.00	25.49	928.4	138.76

Unit Weight of water =

62.4 Specific Gravity of Soil Particles =

2.67

Sample Depth	Moisture Content	Field Density (pcf)	Degree of Saturation
5'-7'	15.98	137.62	1.00
10'-12'	14.09	134.1	0.99
15'-16'	13.83	138.02	0.98
21'-23'	12.19	137.8	0.91
26'-28'	22	119.41	1.00
31'-32'	22.67	NA	NA
37'-38.5'	14.25	138.76	0.99

Boring No.: 2

Location: US-83 over Antilley Road, Abilene, TX

Tested By: Debakanta Mishra

Date of Boring: 18th July 2005

Sample Depth	Height of cylindrical specimen (in)			Mean Height (in)	Diameter of Cylindrical Specimen (in)			Mean Diameter (in)	Volume (in ³)	Weight (g)	Field Density (pcf)
2.5'-4.5'	1.8035	1.697	1.74445	1.75	3.04	3.03	3.03	3.03	12.64	445.05	134.16
5'-7'	2.219	2.26	2.22	2.23	3.00	2.94	3.00	2.98	15.58	542.95	132.74
8'-9.5'	1.636	1.5925	1.592	1.61	3.017	3.0425	3.0225	3.03	11.57	420.09	138.39
10'-12'	1.292	1.3925	1.372	1.35	3.0105	2.978	2.985	2.99	9.50	337.2	135.22
13'-14.5'	2.2625	2.3665	2.3675	2.33	3.009	3.0095	3.001	3.01	16.56	574.54	132.22
18'-20'	1.9865	1.9685	1.943	1.97	3.035	2.973	3.0145	3.01	13.97	487.37	132.96
23'-25'	2	2.0935	2.0715	2.06	3.026	2.985	2.9475	2.99	14.39	493.33	130.61

Unit Weight of water = 62.4 Specific Gravity of Soil Particles = 2.67

Sample Depth	Moisture Content	Field Density (pcf)	Degree of Saturation
2.5'-4.5'	15.89	134.16	1.00
5'-7'	11.43	132.74	0.87
8'-9.5'	12.97	138.39	0.94
10'-12'	11.59	135.22	0.88
13'-14.5'	14.24	132.22	0.99
18'-20'	11	132.96	0.85

Boring No.: 3

Location: US-83 over Antilley Road, Abilene, TX

Tested By: Debakanta Mishra

Date of Boring: 18th July 2005

Sample Depth	Height of cylindrical specimen (in)			Mean Height (in)	Diameter of Cylindrical Specimen (in)			Mean Diameter (in)	Volume (in ³)	Weight (g)	Field Density (pcf)
3'-5'	Density Measurement not Possible										
5'-7'	1.312	1.298	1.26	1.29	3.00	3.02	3.00	3.01	9.17	304.70	126.60
8'-9.5'	3.647	3.6275	3.623	3.63	2.964	2.9965	2.9205	2.96	25.00	925.8	141.09
10'-12'	3.2265	3.224	3.262	3.24	3.022	2.9685	2.995	3.00	22.81	736.8	123.07
13'-15'	1.8665	1.867	1.861	1.86	3.022	3.0585	2.996	3.03	13.41	462.84	131.54
15'-17'	1.791	1.785	1.725	1.77	2.9885	2.9815	2.9575	2.98	12.29	427.89	132.66
17'-18.5'	2.004	2.0405	2.0115	2.02	3.048	3.037	2.9585	3.01	14.41	499.24	132.03

Unit Weight of water =

62.4 Specific Gravity of Soil Particles =

2.67

Sample Depth	Moisture Content	Field Density (pcf)	Degree of Saturation
3'-5'	20.5	NA	NA
5'-7'	14.98	126.60	1.00
8'-9.5'	18.49	141.09	1.00
10'-12'	25.68	123.07	1.00
13'-15'	18.9	131.54	1.00
15'-17'	17.52	132.66	1.00
17'-18.5'	21.11	132.03	1.00

APPENDIX E

SPECIAL SPECIFICATION

3075

Cross-Stitching Cracks and Longitudinal Joints in Concrete Pavement

1. **Description.** Drill holes and anchor deformed tie bar reinforcement diagonally across cracks or longitudinal joints in concrete pavement in accordance with the details shown on the plans and the requirements of this Item.
2. **Materials.** Unless otherwise shown on the plans or directed by the Engineer, use materials that meet the requirements of the pertinent items as follows:
 - A. Item 440, "Reinforcing Steel"
 - B. DMS-6100, "Epoxy and Adhesives," Type VIII (Grout) Class B
3. **Equipment.** Provide tools and equipment necessary for proper execution of the work.
 - A. Drill. Use a maximum 40 lb. hydraulic drill with tungsten carbide bits.
 - B. Air Compressor. Provide compressor capable of delivering air at 120 cu. ft. per minute and with a minimum 90 psi nozzle pressure.
4. **Construction.** Provide the anchoring material Manufacturer's written recommendations to the Engineer. Demonstrate the cross-stitching work to receive approval of the operation procedure and the use of equipments.
 - A. **Drill Holes.** Use drilling operations that do not damage the surrounding concrete. Drill the end holes in a slab at the offset, depth, and angle as shown on the plans. Ensure that the holes are drilled perpendicular to the longitudinal joint or crack (in plan view) at each location being drilled. Drill adjacent holes in opposite directions across the joint or crack. Ensure that the holes diameters are no more than 3/8 in. larger than tie bar diameter.
 - B. **Clean Holes.** Clean holes with oil-free and moisture-free compressed air and a wire brush to remove all cuttings, dust, and other deleterious material. Check the compressed air stream purity with a clean white cloth. Insert the nozzle to the back of the hole to force out all dust and debris. Alternate use of the wire brush and compressed air as necessary until all loose material has been removed.
 - C. **Insertion of Tie Bar.** Place the anchoring material into the back of the hole using a nozzle or wand of sufficient length. Insert the tie bar such that the anchoring material is evenly distributed around the tie bar and slightly extrudes out the hole. Trowel the anchoring material smooth to the pavement surface.

- D. Repairs.** Repair damages to concrete pavement caused by Contractor's operation without any additional compensation. As directed, perform repairs in accordance with Item 361, "Full-Depth Repair of Concrete Pavement" or Item 720, "Repair of Spalling in Concrete Pavement" if spalls are 0.25 to 3 in. depth.
- 5. Measurement.** This Item will be measured by each completed and accepted cross-stitched tie bar.
- 6. Payment.** The work performed and materials furnished in accordance with this Item and measured as provided under "Measurement" will be paid for at the unit price bid for "Cross-Stitching Cracks or Longitudinal Joints in Concrete Pavement." This price shall be full compensation for furnishing all materials, tools, equipment, labor, and incidentals necessary to complete the work. No payment will be made for extra work required to repair damage to the adjacent pavement that occurred during drilling.

SPECIAL SPECIFICATION**7028****Raising and Undersealing Concrete Slabs**

1. **Description.** Raise and underseal concrete slabs at locations shown on the plans and as directed. This work will include drilling injection holes, injection of material, checking elevations to control lift of pavement, cleanup, filling joints and cracks with epoxy grout, if not filled by a polyurethane product, and other related work.
2. **Material.** Furnish epoxy material that meets the requirements of DMS-6100, "Epoxies and adhesives". Use high density polyurethane material, such as Uretek 486 or equivalent.

3. **Equipment.**

- A. **Drill.** Use a drill capable of drilling 1/2 in. or 5/8 in. diameter holes.

- B. **Pump.** Furnish a pump unit capable of injecting the polyurethane:

- between concrete and subbase,
- controlling the rate of the rise of the pavement.

4. **Construction.**

- A. **Preparation.** Prepare a profile of each area to determine the extent of the concrete pavement that requires adjustment or raising.

- B. **Drilling.** Drill a series of 1/2 in. or 5/8 in. injection holes at about 3 to 6 ft. intervals through the concrete in the area to be raised. The Contractor is responsible to determine the exact location and spacing of the holes.

Inject high density polyurethane formulation under the slab. Monitor the rise of the slab by regulating the rate of injection of the high density polyurethane material and by controlling the pumping unit. Remove any excessive polyurethane material after the nozzle is removed from the hole and seal the hole.

- C. **Grade Control.** Before beginning grade adjustments to the slab, submit a detail of the area to be treated with the final proposed grades. Finished concrete grade will conform to the grades and cross-section of the slab.

Ensure that final elevations be within 1/4 in. of the proposed profile elevations. The Engineer may check the treated area to confirm that the pavement has been aligned properly to facilitate drainage.

Repair any pavement blowouts, excessive lifting or uneven pavement that is the result of the raising of the pavement at the expense of the Contractor.

C. Set-Time. Ensure that the high density polyurethane formulation is set to attain 90% of its compressive strength within 15 minutes injection. Attain compressive strength as shown on the plans, as recommended by the manufacturer.

5. Measurement. This Item will be measured by the pound.

6. Payment. The work performed and materials furnished in accordance with this Item and measured as provided under "Measurement" will be paid for at the unit price bid for "Raising and Undersealing Concrete Slabs". This price is full compensation for furnishing and injecting material, all labor, materials, tools, and incidentals.

SPECIAL SPECIFICATION**3037****Slot-Stitching Longitudinal Joints in Concrete Pavement**

1. **Description.** Install tie bars across longitudinal cracks or joints in concrete pavement in accordance with the details shown on the plans and the requirements of this item.
2. **Materials.** Furnish the following materials, unless otherwise shown on the plans or directed by the Engineer:
 - A. **Concrete.** Provide Class HES concrete conforming to Item 421, “Hydraulic Cement Concrete,” with the following exceptions or additions:
 1. Design concrete mix with a maximum water to cement ratio of 0.38, and a minimum average flexural strength of 700 psi at the age of 48 hours. Test in accordance with Tex-448-A.
 2. Use aggregate from siliceous sources only. Provide washed aggregate with 100% passing the 1/2 in. sieve. No more than 15% of the mix must be of any one size of aggregate.
 3. Use shrinkage reducing or compensating admixtures, or water reducing admixtures as approved. Do not use retarding admixtures. When using any admixtures, document the type, quantity, and location of mix placement on a copy of the final plans.
 4. The use of proprietary, high strength, rapid setting mixes may be approved when the materials demonstrate the satisfied performance. Obtain approval for the materials and proportions before using. Document the placement locations and material properties of proprietary materials on a copy of the final plans.
 - B. **Reinforcing Steel.** Provide reinforcing steel in accordance with Section 360.2.B, “Reinforcing Steel.”
 - C. **Epoxy.** Provide epoxy materials for bonding new concrete to old concrete or for concrete repair materials that conforms to DMS-6100, “Epoxy and Adhesives.”
 - D. **Membrane Curing Compound.** Provide membrane curing compounds that conform to the requirements of DMS-4650, “Hydraulic Cement Concrete Curing Materials and Evaporation Retardants”, Type 2, Class A.
3. **Construction Methods.** Demonstrate slot-stitching work for approval of all the equipment and procedures. Provide tie bars at locations and spacing as detailed in the plans.
 - A. **Slot Formation.**

1. Provide slots using multiple saw cuts made with a diamond impregnated saw blade to a depth at most 5 in. This depth will provide the needed clearance under the tie bars for the support devices and for encasing the tie bars in the repair material.
2. The slot is 2 1/2 in. minimum and at most 4 in. wide.
3. Provide enough length of the cut to allow the tie bar to be placed at the mid-depth of the slab without toughing the ends of the slot.
4. Use lightweight jackhammers less than 30 lb. or hand tools to remove the “fins” formed by sawing.
5. Do not spall or fracture concrete adjacent to the slots. Repair damages to concrete pavement caused by Contractor’s operation without any additional compensation. Repair in accordance with Item 361, “Full-Depth Repair of Concrete Pavement” or Item 720, “Repair of Spalling in Concrete Pavement” if spalls are 0.25 to 3 in. in depth, or as approved.

B. Tie Bar Placement.

1. Rinse the slot with potable water, sand blasted, and blown clean and dry with high pressure air to remove sand, water and dust.
2. Prime or coat the slot with an epoxy bonding agent designed to bond fresh concrete to cured concrete.
3. Place tie bars at locations and spacing as detailed in the plans. Place the tie bars on support chairs so that the tie bars rest horizontal at the mid-depth of the slab.

C. Repair Material Placement.

1. Do not place concrete when the air temperature is below 65°F. Use a vibrator head at most 1 in. in diameter to consolidate the concrete repair material. Do not dislodge or move the tie bar out of position, but the repair material must fill the space under the bar.
2. Finish the repair material level with the existing slab surfaces.
3. Cure the repair surface in accordance with Section 360.4.I. If a proprietary mix is used, use manufacturer’s curing procedure.
4. Use insulation blankets to facilitate curing and the strength gain of repair areas if desired. Provide insulating blankets with a minimum thermal resistance (R) rating of 0.5 hour-square foot °F/BTU and in good condition.
5. Make and cure concrete compressive strength test specimens as directed.

- D. Opening to Traffic.** The pavement may be opened to traffic after all tie bars have been installed at a joint and the concrete has obtained a minimum average flexural strength of 700 psi or as directed by the Engineer. Determine the flexural strength in accordance with Tex-448-A by using concrete specimens cured at the job site under the same conditions as the pavement. Opening the pavement does not relieve the Contractor from

his responsibility for the work in accordance with Item 7, “Legal Relations and Responsibilities.” Seal all joints and clean the pavement before opening the pavement to traffic.

4. **Measurement.** This Item will be measured as each completed and accepted tie bar complete in place.
5. **Payment.** The work performed and materials furnished in accordance with this Item and measured as provided under “Measurement” will be paid for at the unit price bid for “Slot-Stitching Longitudinal Joints in Concrete Pavement”. This price is full compensation for furnishing all materials, tools, labor, equipment and incidentals necessary to complete the work. No payment will be made for extra work required to repair damage to the adjacent pavement that occurred during sawing.

SPECIAL SPECIFICATION**7115****Riprap and Drainage Channel Cleaning**

1. **Description.** Clean concrete riprap and drainage channels within the limits shown on the plans.
2. **Equipment.** Provide highly visible omnidirectional flashing warning lights on work vehicles. The Engineer will inspect and approve all equipment prior to use. Replace or repair any equipment the Engineer determines to be defective to the point that it may affect the quality of the work.
3. **Work Methods.** Remove and dispose of all debris, unwanted vegetation, and silt on the riprap and/or in the concrete drainage channels in accordance with the details shown on the plans. Dispose of all debris and vegetation removed at a State-approved solid waste site. Dispose of all silt removed as directed.
4. **Measurement.** This Item will be measured by the cycle per location as indicated on the plans.
5. **Payment.** The work performed and materials furnished in accordance with this Item and measured as provided under "Measurement" will be paid for at the unit price bid for "Riprap and Drainage Channel Cleaning". This price is full compensation for furnishing and operating all equipment and for all labor, fuel, materials, tools, and incidentals. All work required to be done by hand labor methods adjacent to structures or other obstructions will not be paid for directly, but will be subsidiary work to this Item.

SPECIAL SPECIFICATION**7074****Blade Level-Up with Asphalt Concrete**

- 1. Description.** Prepare the pavement for an asphalt concrete level-up. Place an asphalt concrete level-up course or courses and compact the courses at location shown on the plans or at location as directed. Repair the front slope to eliminate any drop off created by the level-up and place temporary pavement markers for lane lines.
- 2. Materials.** Furnish all material(s) meeting the following requirement unless otherwise shown on the plans.
 - A. Tack Coat:** Furnish CSS 1H, SS 1H, or a performance-graded (PG) binder with a minimum high-temperature grade of PG 58 for tack coat in accordance with Item 300, "Asphalts, Oils, and Emulsions," unless other types of asphalt are required on the plans. Do not dilute emulsified asphalts at the terminal, in the field, or at any other location before use. The Department may sample the tack coat to verify specification compliance.
 - B. Asphalt Concrete Mixture.** Furnish the types of asphalt concrete materials meeting one of Item 330, "Limestone Rock Asphalt," Item 334, "Hot-Mix Cold-Laid Asphalt Concrete Pavement, or Item 340, "Dense-Graded Hot-Mix Asphalt (Method)." The item, type and grade of aggregate, binder, and state aggregate classification (SAC) and other material requirements will be as shown on the plans when applicable.
 - C. Removable and Short-Term Markings.** Use raised pavement markers, removable prefabricated pavement markings, temporary flexible reflective roadway marker tabs, or other approved materials for removable and short-term markings. Do not use hot-applied thermoplastic or traffic paint for removable markings. Use removable prefabricated pavement markings on the final pavement surface when the plans specify removable markings that meet the requirements of DMS 8241. Reflective tabs shall meet the requirement of DMS 8442.
 - D. Material Furnished by the Department.** Pick up or load material furnished by the Department at locations shown on the plans or designated by the Engineer. Do not use any material furnished by the Department for any work not a part of the contract. Return all unused furnished materials to the Department upon completion of the work and prior to final payment to the location from which the materials were obtained.
- 3. Equipment.** Furnish equipment to produce, haul, place, compact, and test the level up in accordance with Item 320, "Equipment for Asphalt Concrete Pavement." Maintain all equipment for the handling, mixing, and placing of all materials in good repair and operating condition, as approved. Replace any equipment found defective and affecting the quality of the paving mixture.

4. Construction Methods. Construct the level up in accordance with the following.

- A. General.** Transport, place and compact the specified paving mixture, in accordance with this Item and as approved. Place mixture when the roadway surface temperature is 60°F or higher unless otherwise approved. Measure the roadway surface temperature with a handheld infrared thermometer. Unless otherwise shown on the plans, place tack coat and mixture only when weather conditions and moisture conditions of the roadway surface are suitable in the opinion of the Engineer.
- B. Preparation of Surface.** Before the placement of tack coat, prepare the roadway surface by removing traffic buttons or jiggle bars from the paved level-up area. Remove grass and turf from the edge of the pavement by using a motor grader blade. Thoroughly clean and sweep loose material from the roadway surface before the application of tack coat to the satisfaction of the Engineer. Patch potholes by cleaning the hole of loose material, placing tack coat in hole, placing level-up material in the hole, and compacting by approved means. Spread loose material uniformly across the toe of the slope.
- C. Tack Coat.** Clean the surface before placing the tack coat. Unless otherwise approved, apply tack coat uniformly at the rate directed. The Engineer will set the rate between 0.04 and 0.10 gal. of residual asphalt per square yard of surface area. Apply a thin, uniform tack coat to all contact surfaces of curbs, structures, and joints. Prevent splattering of the tack coat when placed adjacent to curb, gutter, and structures. Roll the tack coat with pneumatic-tire roller when directed. The Engineer may use Tex-243-F to verify that the tack coat has adequate adhesive properties. The Engineer may suspend paving operations until there is adequate adhesion.
- D. Placement.** Place the asphalt concrete mixture in accordance this specification and the plans and with specifications of the asphalt concrete being used (Items 330, 334 or 340) or as directed. Windrow and pull the material across the entire patch or area to be leveled up not to exceed 1 in. lifts for cold laid asphalt concrete mixtures. Add the material in lifts and rolled until the desired grade can be reached. Do not exceed compacted lift thicknesses specified in Table 8 in Item 340.4.F, when placing hot laid asphalt concrete mixtures. Feather all edges including each end of the patch or level up into the existing pavement as to eliminate any bump left by excess material. This can be accomplished by using a motor grader or by hand, using asphalt rakes. Roll each lift until the roller does not track the material.

Take extreme care when using a vibratory roller on these lifts. The Engineer may restrict the use of a vibratory roller if there is deterioration of the mat. After the final pass is made by a motor grader, use the flat-wheel roller until roller marks are removed and to seal the finished asphalt concrete mixture patch or level up.

- E. Compaction.** Compact the pavement thoroughly and uniformly with the necessary rollers to obtain the density, stability and cross section of the finished paving mixture, as specified in the plans and specifications and to the approval of the Engineer.

Begin rolling longitudinally at the sides and proceed toward the center, overlapping on successive trips by at least 1/2 the width of the rear wheel, when rolling with the three-wheel, tandem or vibratory rollers, unless otherwise directed. Offset alternate trips of

the roller. On superelevated curves, begin rolling at the low side and progress toward the high side.

When rolling with vibratory steel-wheel rollers, follow the manufacturer's recommendation unless directed otherwise. Roll with pneumatic tire roller as directed. Continue rolling until no further density can be obtained and all roller marks are eliminated. Compact thin irregular level-up courses as directed.

Avoid displacement of the mixture. To prevent adhesion of the surface mixture to the roller, keep wheels thoroughly moistened with water, but an excess of water will not be permitted. Allow motion of the roller to be slow enough at all times to avoid displacement of the mixture. If any displacement occurs, correct it at once by the use of rakes, and with fresh mixture where required. Do not allow roller to stand on pavement which has not been fully compacted. Take necessary precautions to prevent the dripping of gasoline, oil, grease or other foreign matter on the pavement, either when the rollers are in operation or when standing.

- F. Hand Tamping.** Hand tamp to thoroughly compact the edges of the pavement along curbs, headers, and similar structures and in locations that will not allow thorough compaction with the rollers.
 - G. Pulling Shoulders.** Unless otherwise specified on the plan pull the front slope with the motor grader to make a smooth transition to the pavement surface and to eliminate any drop off between the asphalt surface level up and the front slope.
 - H. Lane Line.** Unless otherwise shown on the plans place temporary lane line using reflective tabs on the level up areas each day before leaving the work area. Spacing is shown on the plans.
- 5. Surface Test.** The Department will test drive the patch or level up to determine if adequate grade and riding surface has been achieved. If the ride is considered rough the Department will test the ride quality in accordance with Surface Test Type A for Item 585. For the Type "A" test In lieu of the 1/8-in variation allowed between any 2 contracts on the 10-ft. straight edge, a 3/16-in. variation will be allowed. If the pavement section fails the straight edge test, take corrective action in accordance with Item 585 or as directed by the Engineer.
- 6. Measurement.** Level up asphalt concrete which includes asphalt, aggregate and additive will be measured for payment by one of the following methods.
- 1. Measure by square yard in place.
 - 2. Measure by the ton of composite asphalt concrete, which includes asphalt, aggregate and additives. Measure the weight on scales in accordance with Item 520, "Weighting and Measuring Equipment.
 - 3. Measure by the cubic yard of composite asphalt concrete material in trucks to be applied on the road. The Engineer may require loaded material to be struck off for accurate measurement. The load will be documented by issue ticket, signed by the designated signatories for the Department.

7. **Payment.** Level up asphalt concrete which includes asphalt, aggregate and additive will be measured for payment by one of the following methods.

Work performed in accordance with this Item and measured as provided under “Measurement” paid for at the unit price bid for “Blade Level-Up” of one of the following:

- “Limestone Rock Asphalt,” of the type, grade and surface aggregate classification specified,
- “Hot-Mix Cold-Laid Asphalt Concrete Pavement,” of the type, surface aggregate classification and asphalt binder specified,
- “Hot-Mix Asphalt,” of the type, surface, aggregate classification, and binder specified,

and with indication of who furnishes the material (the Contractor or State.)

This will fully compensate for cleaning the existing pavement, hauling and placing tack coat and asphalt concrete material, rolling and finishing, installing reflective tabs or removable stripes, pulling shoulders and for all manipulations, labor, tools, equipment, all material required to be furnished by the plans, and incidentals necessary to complete the work. Preparation of surface, such as but not limited to filling and compacting holes is subsidiary to the bid item in the contract unless otherwise shown on the plans.

APPENDIX F

**SITE ASSESSMENT PROTOCOL
FOR THE EVALUATION OF BRIDGE END DAMAGE DUE TO WATER
INTRUSION**

PART A: Inspect Bridge End for Evidence of Water Intrusion

- Check if base/subgrade had been found at or near full saturation conditions during previous maintenance activities
- Has any seepage been noticed on the approach pavement or on embankment slopes?
- Has water been found to collect in exploratory boreholes or holes for guardrail posts, sign posts etc. that had been drilled in the bridge end?
- Is there any evidence of erosion of base/subgrade materials (e.g.. visible voids, washed out material that is deposited elsewhere)?
- Settlement of the approach with respect to the bridge structure (Note: Many other factors contribute to settlement of the approach and therefore, settlement does not necessarily indicate a water intrusion problem)

If data collected in Part A indicates that water intrusion is a likely to be a factor that contributed to bridge end deterioration then

PART B: Identify Source of Water

- Inspect joints between approach slab and bridge wings, approach slab and pavement, approach slab and mow strip
 - Joints are properly sealed so that no significant water intrusion may occur through these joints
 - Joints are not sealed properly and therefore, it is likely that they serve as access points for surface water to infiltrate into the base and subgrade
- Inspect the approach slab and pavement for cracks through which water may enter
 - Only minor cracks are present/cracks have been adequately sealed
 - Cracks may allow water to infiltrate into the base/subgrade soils but do not significantly impact structural integrity of the approach/pavement slabs
 - Approach and/or pavement slab is severely cracked, that they not only provide ready access for water intrusion but also compromise structural integrity of the approach/pavement slab
- Inspect bridge end for other, less conspicuous pathways for water (for example improperly backfill core holes)

- Determine the depth to groundwater table; If a fine-grained soil had been used in the construction of the embankment, and the groundwater table is shallow, the soil will be capable of drawing moisture from the groundwater table and become very wet. This situation may be most commonly found in at-grade bridges at stream crossings

PART C: Evaluate the Adequacy of the Surface Water Drainage System

- Is the design of the surface water drainage system adequate? Is it consistent with the amounts of rainfall received at that particular region?
 - The dimensions of the drainage flume is adequate to handle surface runoff generated during a heavy rainfall event
 - The dimensions of the drainage flume has been observed to be inadequate
 - The height of the curb is adequate to contain the surface runoff within the flume
 - The height of the curb is not adequate to contain the surface runoff within the flume as the water turns the corner from the approach slab into the flume
- In bridges that allow lateral flow of surface water through slots in the bridge rail, check whether the riprap is wide enough to catch the drip
 - Riprap is wide enough
 - Riprap is not wide enough to catch the lateral drip; erosion of the embankment may occur
- Verify that the surface drainage system is functioning according to the original design. In other words, the drainage flumes should not be blocked as result of subsequent construction and maintenance work (e.g. installation of the new monocurb and thriebeam guardrail system may block the original surface drainage system and prevent it from functioning properly).
 - No obstructions; Surface drainage system should function as originally designed
 - Obstructions to surface drainage has occurred as a result of subsequent construction
- Has the surface water drainage system been maintained properly? Inspect the drainage flumes for unsealed joints, cracks, debris accumulation, weed growth etc.
 - Surface water drainage system has been properly maintained
 - Unsealed cracks and joints that may allow water to infiltrate into the base/subgrade are present

- Debris has accumulated in the drainage pathway preventing the drainage flume from functioning properly
- Growth of vegetation within the drainage flume is preventing it from functioning properly

PART D: Selection of a Maintenance Strategy

In the following section, the maintenance strategies are listed according to cost of implementation. The least expensive, preventive type maintenance strategies are listed first. These strategies will be acceptable for bridges in which bridge end deterioration is minimal. Bridge ends that are more severely affected would require more extensive rehabilitation work. These repair strategies are found towards the bottom of the list.

- D1. Seal Cracks and Joints:** Any cracks and joints found in the approach slab, approach pavement, mow strip, drainage plumes must be cleaned and properly sealed. If it is suspected that cracks in the approach slab may have resulted in erosion of base/subgrade soils, further action is needed as detailed in D6 and D7 below.
- D2. Seal Other Pathways that Allow Water Intrusion:** If bridge end inspection had identified any other, less obvious pathways that may serve as access points for water intrusion, they must be sealed off as well.
- D3. Modify Surface Drainage System Design, if Necessary:** If it is determined that the drainage system design is not adequate, then necessary changes in the design must be implemented. These may involve measures such as increasing dimensions of the drainage flume, increasing the height of curb around the drainage flume etc.
- D4. Clear Surface Drainage System of any Obstructions:** The surface drainage system must be cleaned periodically to ensure that it can function efficiently without being compromised by accumulating debris, weed growth etc. If drainage pathways have been blocked by subsequent maintenance work, then reconstruction of the drainage system must be undertaken.
- D5. Leveling Up using Asphalt Overlay:** This may be used as a cost effective solution to correct ride quality problems resulting from settlement of the approach embankment with respect to the bridge when soil erosion problem is not present. Settlement of the embankment/supporting foundation soil may continue to occur for many years after the construction of the bridge and therefore, repeated application of overlays will be necessary.
- D6. Slab Stabilization and Undersealing:** Slab stabilization and undersealing must be undertaken if minor void development has occurred. This will prevent further deterioration of the slab by pumping, faulting, corner breaks and further loss of soil support.
- D7. Slab Jacking:** If the slab has already settled due to development of larger voids, these voids must be filled and the slab raised by pumping cement grout or polyurethane foam under the slab. Slab jacking using polyurethane foam is

more expensive but is preferred by many maintenance engineers who have used this process. The process provides better control and faster completion compared to slab jacking with conventional cement grout. The extra cost may be justified in bridges that carry heavy volumes of traffic.

- D8. Patching Approach Slab:** If a particular portion of the approach slab is badly damaged, then it will be necessary to remove and replace the unsound portion of the slab. This can be accomplished with a full depth patching of the slab. Once the old, damaged concrete has been removed, replacement of the removed portion of the slab can be accomplished in two different ways. The first method is to use a new in-situ pour. The second is to use a precast panel.
- D9. Slot Stitching, Cross-Stitching and URETEK Stitch in Time:** Slot Stitching, Cross-Stitching and URETEK Stitch in Time are techniques that can be used to enhance load transfer across joints and cracks. Whenever patching of the slab is undertaken, load transfer between the patched portion of the slab and original slab must be accomplished through one of these techniques.
- D10. Approach Reconstruction:** If the bridge approach has suffered extensive damage then its rehabilitation may not be achieved economically with any of the bridge repair alternatives described above. In this case, reconstruction of the approach will be necessary. These projects will typically involve removal of either the entire approach slab or major portions of it. One major advantage in approach reconstruction is that it allows implementation of other remedial measures to address the “root causes” of the problem. Such remedial measures may include: (a) removal weak embankment material and replacing it with non-erodible, stable material such as cement stabilized backfill or, (b) installation of a subsurface drainage system. More complete description of approach reconstruction is found in Chapter V of the report.