

CULVERT RATING GUIDE

SECOND EDITION

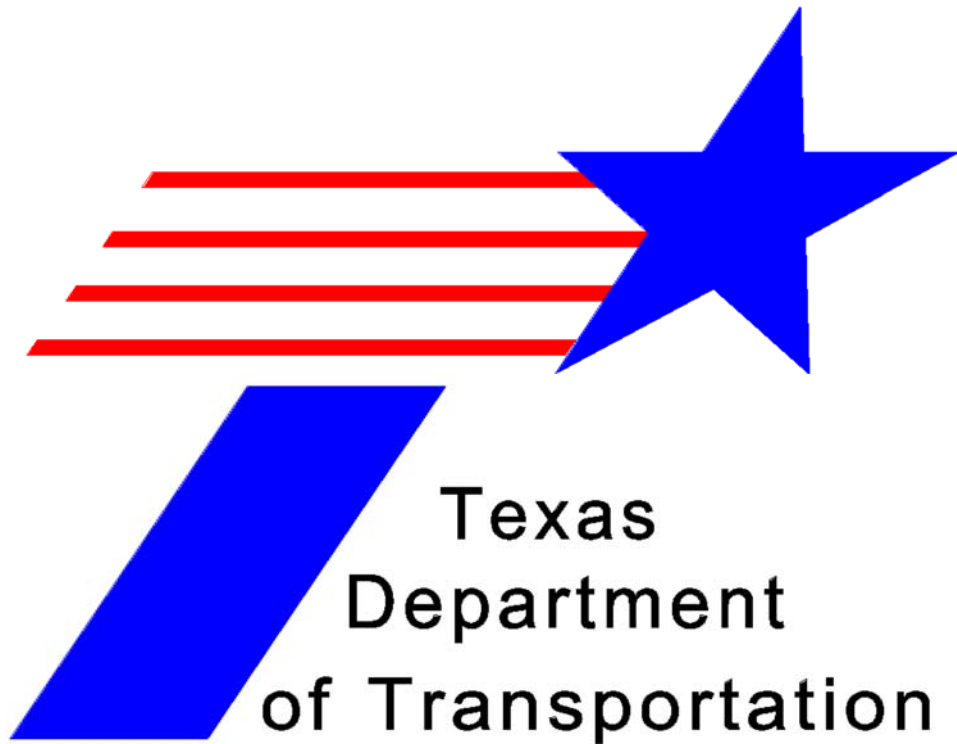

October 2017

©2017 Texas Department of Transportation
all rights reserved

(page intentionally left blank)

Texas Department of Transportation

Culvert Rating Guide, Second Edition

WILLIAM D. LAWSON, P.E., PH.D.

Department of Civil, Environmental and Construction Engineering
Texas Tech University, Lubbock, Texas

HOYOUNG SEO, PH.D., P.E.

Department of Civil, Environmental and Construction Engineering
Texas Tech University, Lubbock, Texas

JAMES G. SURLS, PH.D.

Department of Mathematics and Statistics
Texas Tech University, Lubbock, Texas

STEPHEN M. MORSE, PH.D.

Department of Civil & Environmental Engineering
Michigan Technological University, Houghton, Michigan

Subject Areas

Reinforced Concrete Box Culverts, Load Rating, Load Posting, Structural Analysis

Research Sponsored by the Texas Department of Transportation
in Cooperation with the Federal Highway Administration

Texas Department of Transportation
Austin, TX – 2017

RESEARCH PROGRAM SPONSORSHIP

The *Culvert Rating Guide, Second Edition* was developed as part of Texas Department of Transportation (TxDOT) Interagency Contract No. 88-7XXIA001, “Improving TxDOT’s Culvert Load Rating Process and Software,” executed on 12 October 2016, and TxDOT Interagency Contract No. 88-4XXIA001, “Load Rating TxDOT pre-1980 In-Service Culverts,” executed on 1 August 2014, both under the aegis of the TxDOT Bridge Division. In turn these contracts built on and further extended earlier TxDOT research studies on culvert load rating. These included project No. 0-5849, “Evaluating Existing Culverts for Load Capacity Allowing for Soil Structure Interaction,” funded in September 2007; project No. 5-5849-01, “Software Development to Implement the TxDOT *Culvert Rating Guide*,” funded in May 2012; and project No. 5-5849-03, “Load Rating TxDOT Culvert Design Standards,” also funded in May 2012. These earlier projects were sponsored through TxDOT’s Research Management Committee 5 (Structures and Hydraulics).

The TxDOT Project Advisory Committee for this research included the following persons:

MANUEL B. “BERNIE” CARRASCO, P.E., *Bridge Division* (Lead Project Advisor)
JESUS ALVAREZ, E.I.T., *Bridge Division* (Project Advisor)
GRAHAM A. BETTIS, P.E., *Bridge Division* (Project Advisor)
GREGG A. FREEBY, P.E., *Bridge Division* (Project Advisor)
JOSUHA GUTZWILLER, E.I.T., *Bridge Division* (Project Advisor)
YI QIU, P.E., *Bridge Division* (Project Advisor)

The members of the Project Advisory Committee selected to monitor this project and to review this document were chosen for recognized scholarly competence and with due consideration for the balance of disciplines appropriate to the project. This report was reviewed and accepted for publication by the advisory committee according to procedures established and monitored by the TxDOT Research and Technology Implementation Office.

PUBLICATION NOTE

The authors submitted the DRAFT *Culvert Rating Guide, 2nd Edition* on October 12, 2017. TxDOT accepted the DRAFT document – with administrative revisions only – on June 14, 2018. The FINAL version of the *Culvert Rating Guide, 2nd Edition* (this document) was published July 20, 2018. To facilitate clarity and historical continuity, the date of substantial completion – *October 2017* – is identified as the formal publication date for this document.

AUTHOR ACKNOWLEDGEMENTS

The research upon which the *Culvert Rating Guide, Second Edition* is based represented a collaborative effort of two entities: the Center for Multidisciplinary Research in Transportation at Texas Tech University that performed the research and the TxDOT Project Advisory Committee that provided oversight and review. The authors acknowledge the contributions of each committee member, of the co-authors of the original *Culvert Rating Guide*, as well as the work of many other faculty members, research associates, and students who participated in the various culvert rating research studies. The authors thank each of these persons for their technical capability, professionalism, and enthusiasm for the project.

TABLE OF CONTENTS

Table of Contents iv

List of Figures..... viii

List of Tables..... ix

List of Equations x

1. Introduction1

 A. Purpose.....1

 B. What’s New in the Second Edition1

 C. Definition2

 D. TxDOT’s Culvert Population3

 E. Scope4

 F. A Reasonable Expectation of Satisfactory Performance4

 G. Rating Philosophy7

 H. About this Guide.....7

2. Policy Requirements9

 A. Policy Source Documents9

 B. Load Factor Rating.....10

 C. Load Rating Vehicle Load Patterns10

 D. Load Rating Equation.....13

 E. Critical Sections14

 F. Failure Modes.....16

 G. Policy Rating Variables – Level 1 (2D Structural Frame).....16

 H. Policy Rating Variables – Level 3 (2D Soil-Structure Interaction)18

 I. Qualifications of Load Rating Personnel.....19

3. Culvert Load Rating Procedure21

 A. Context for Load Rating.....21

 B. Visual Inspection of the Culvert.....22

 C. The Culvert Load-Rating Process22

 D. Selection of the Proper Level of Analysis.....25

 E. Reviewing and Checking Calculations.....25

4. Culvert Document Capture and Classification27

 A. The “Ideal” Culvert Document File27

 B. Compiling a Reasonably Complete Culvert Document File28

 C. Readily Available Documentation.....29

 D. Geotechnical Documentation.....30

 E. Pavement Documentation.....31

 F. Culvert Structural Properties33

 G. Structure Condition Rating Data.....33

 H. The “Production-Simplified” Dataset33

 I. CULVLR 2.0 Software – Culvert Document Capture34

 J. Example Problem – Culvert Document Capture.....34

- 5. **Structure History and Segment Interpretation** 35
 - A. The Need for Segment Identification 35
 - B. The Culvert Segment Concept..... 35
 - C. Culvert Segments in Pre-1980 Culvert Structures 36
 - D. Segment Identification Process..... 37
 - E. Quality Score for Structure History and Segment Identification..... 38
 - F. CULVLR 2.0 Software – Structure History and Segment Identification 40
 - G. Example Problem – Structure History and Segment Identification..... 40
- 6. **Parameter Interpretation and Data Capture** 41
 - A. Parameters for Culvert Load Rating 41
 - B. Overview of the Parameter Identification Process 42
 - C. Units and Dimensions 43
 - 1. Units 43
 - 2. Dimensions..... 43
 - D. Data Typical to the Project File 44
 - E. Quality Score for Parameter Identification 46
 - F. Soil Data 47
 - 1. Soil Unit Weight 47
 - 2. Soil Poisson’s Ratio and Modulus..... 48
 - G. Pavement Data..... 50
 - H. CULVLR 2.0 Software – Parameter Identification and Data Capture 51
 - I. Example Problem – Parameter Identification and Data Capture 51
- 7. **Design Selction**..... 53
 - A. Design Selection for Culvert Load Rating 53
 - B. TxDOT’s Use of Design Standards 54
 - C. Culvert Design Eras..... 54
 - D. TxDOT’s Families of Standard Culvert Designs 56
 - E. Digitization of Design Standards – “Digital Design Collective” 56
 - F. The “Design Selction” Task..... 57
 - G. Segment Design Identification – Quality Rating Process..... 58
 - H. CULVLR 2.0 Software – Design Selection..... 60
 - I. Example Problem – Design Selection 60
- 8. **Culvert Capacity Calculations** 61
 - A. Policy for Capacity Calculations..... 61
 - B. Sign Convention for Load Rating Calculations..... 61
 - C. Bending Moment Capacity..... 62
 - D. Shear Capacity..... 66
 - E. Thrust Capacity..... 68
 - F. CULVLR 2.0 Software – Culvert Capacity Calculations..... 68
 - G. Example Problem – Culvert Capacity Calculations 68

- 9. **Level 1 (Structural Frame) Analytical Model** 69
 - A. Overview 69
 - B. Generalized Step-by-Step Procedure for Determining Demand Loads 69
 - C. Shear Failure Mode Analysis 70
 - D. Level 1 Analysis: Two-Dimensional, Simply-Supported Structural Frame Model 72
 - 1. Assumptions 72
 - 2. Model Dimensions 73
 - 3. Boundary Conditions 74
 - 4. Loads 74
 - 5. Load Cases 82
 - 6. Demand Load Calculations 83
 - 7. Analytical Program – CULV-5 83
 - E. CULVLR 2.0 Software – Level 1 Analytical Model 89
 - F. Example Problem – Level 1 Analytical Model 89
 - G. Reporting Level 1 Load Rating Results 89
- 10. **Level 3 (Soil-Structure Interaction) Analytical Model** 91
 - A. Overview 91
 - B. Generalized Step-by-Step Procedure for Determining Demand Loads. 92
 - C. Level 3 Soil-Structure Interaction Model 93
 - 1. Assumptions 93
 - 2. Model Dimensions 93
 - 3. Boundary Conditions 94
 - 4. Loads 94
 - 5. Load Cases 96
 - 6. Demand Load Calculations 96
 - D. Analytical Program – RISA-3D 97
 - 1. Overview 97
 - 2. RISA-3D Strengths and Limitations 97
 - 3. RISA-3D Step-by-Step Instructions 98
 - E. CULVLR 2.0 Software – Level 3 Analytical Model 99
 - F. Example Problem – Level 3 Analytical Model 99
 - G. Reporting Level 3 Load Rating Results 100
- 11. **The General Analytical Model for Culvert Load Rating** 101
 - A. Overview 101
 - B. The Level 4 Analysis Defined 101
 - C. When to use a Level 4 Analysis 101
 - D. Comments on Two-Dimensional vs. Three-Dimensional Models 102
 - 1. Level 4 Analysis with a Two-Dimensional Model 102
 - 2. Level 4 Analysis with a Three-Dimensional Model 103
 - E. Practical Considerations for Level 4 Culvert Load Rating Analyses 104
 - F. Level 4 Not Supported by CULVLR 2.0 Software 104
 - G. Non-Destructive Load Testing 104

12. Limitations 105

 A. Overview 105

 B. Culvert Type 105

 C. Fill Depth 105

 D. Backfill Drainage 105

 E. Soil Parameters 106

 F. Analytical Model 106

References 107

Appendix A. Example – Document Capture and Classification A-1

Appendix B. Example – Structure History and Segment Interpretation B-1

Appendix C. Example – Parameter Interpretation and Data Capture C-1

Appendix D. Example – Design Selection D-1

Appendix E. Example – Level 1 and Level 3 Load Rating E-1

Appendix F. Example -- Reporting F-1

LIST OF FIGURES

Figure 1. Complex 7-span reinforced concrete box culvert; Nueces County, Corpus Christi District; original construction 1924, widened/ lengthened 1947; Structure #161780010202005.....	1
Figure 2. Build years for Texas culverts, with 81 percent constructed prior to 1980.....	3
Figure 3. Culvert Inspection Condition Rating vs. Original Year Built ($n = 998$).....	5
Figure 4. Load Rating Results for Load Rated Segments ($n = 1,385$).....	6
Figure 5. Standard HS-20 Truck.....	11
Figure 6. Live load models identified in the AASHTO <i>MBE</i>	12
Figure 7. Three dimensional view of a culvert indicating two dimensional strip.....	14
Figure 8. Moment critical sections for culverts without haunches.....	15
Figure 9. On System Load Posting Guidelines (TxDOT Bridge Inspection Manual Fig.5-3).	21
Figure 10. TxDOT Culvert Load Rating Procedure.....	23
Figure 11. A Complete Set of Original Construction Documents May Be Difficult to Locate and Obtain. ...	28
Figure 12. For Initial Load Rating Efforts, it is Rare to Obtain Project-Specific Data from the Field.	29
Figure 13. The Document File for all Bridge-Class Culverts Typically Contains a <i>Bridge Inventory Record</i> . .	30
Figure 14. TxDOT’s Pavement Management Information System contains the “Pavement Type” for Roads Overlying Culvert Structures.....	32
Figure 15. The concept of culvert segments: (a) one-segment culvert and (b) three-segment culvert..	35
Figure 16. Culvert Load Rating Performance by Number of Segments.	36
Figure 17. Syntax and Interpretive Key for Segment Identification.	37
Figure 18. Interpretation Quality Score for Structure History and Segment Identification.....	40
Figure 19. Data Needed to Load Rate a Culvert Segment.....	41
Figure 20. Culvert Dimensions.	44
Figure 21. Quality Score for Interpretation Parameters, all Ratable Segments for Batch 1 Culverts.	47
Figure 22. TxDOT Culvert Design Standard: Original Design (‘MC8-3’).	53
Figure 23. Detailed Specification, 4-span, 5’ x 5’ box culvert, TxDOT Culvert Design Standard ‘MBC-3’.....	54
Figure 24. Quality Score for Design Selection, all Ratable Segments for Batch 1 Culverts.....	60
Figure 25. Shear critical sections for culverts without (a) and with (b) haunches.	71
Figure 26 Model dimensions for a Level 1 analysis for culverts without (a) and with (b) haunches.	73
Figure 27. Boundary conditions for two dimensional, simply-supported structural frame model.....	74
Figure 28. Load conventions for two dimensional, simply-supported structural frame model.....	75
Figure 29. Live load distribution for $D < 2'$ for two dimensional, simply-supported structural frame analysis.	81
Figure 30. Live load distribution for $2' < D < 8'$ for two dimensional, simply-supported structural frame analysis ...	81
Figure 31. Live load distribution for $D > 8'$ for two dimensional, Simply-supported structural frame analysis.....	81
Figure 32. CULV-5 input format.	86
Figure 33. CULV-5 member and critical section design.....	87
Figure 34. Soil Structure Interaction model Layout.	93
Figure 35. Live load distribution for 2D finite element model with soil structure interaction.	96

LIST OF TABLES

Table 1. Culvert load rating variables for Level 1 Load Rating as per AASHTO policy 16

Table 2. Culvert load rating variables for Level 3 Load Rating as per AASHTO policy 18

Table 3. Quality score rubric for structure history and segment identification 39

Table 4. Culvert dimensions required for load rating calculations 43

Table 5. Load rating parameters required for load rating calculations 45

Table 6. Quality score rubric and calculation algorithm for interpreted parameters 46

Table 7. Resilient modulus of soil for Level 3 live load model 49

Table 8. Equivalent modulus for simplified beam model for pavement 51

Table 9. Classification of TxDOT design standards by era..... 55

Table 10. Summary of TxDOT original design standards families..... 56

Table 11. Quality score rubric and calculation algorithm for segment design selection..... 58

LIST OF EQUATIONS

Equation 1. The rating factor equation (*MCEB* 6.5.1 eq.6-1a)..... 13

Equation 2. The load rating equation (*MCEB* 6.5.1 eq.6-1b): 14

Equation 3. Centroid of the section at ultimate capacity (derived for *SSHB* 8.16.3.4)..... 62

Equation 4. Stress in the compression steel (psi) (derived for *SSHB* 8.16.3.4)..... 63

Equation 5. Stress in compression steel at balanced steel (*SSHB* 8.16.3.4.3 eq.8-28). 63

Equation 6. Rho balanced for doubly reinforced slabs (*SSHB* 8.16.3.4.3 eq8-27). 64

Equation 7. Maximum reinforcing check (derived from *SSHB* 8.16.3.1.1). 64

Equation 8. Generalized moment capacity (derived from *SSHB* 8.16). 65

Equation 9. Minimum cracking moment capacity. 65

Equation 10. Minimum shear capacity (derived from *SSHB* 8.16.6.7)..... 66

Equation 11. Shear capacity equation (*SSHB* 8.16.6.7.1 eq.8-59). 67

Equation 12. Thrust capacity (*SSHB* 8.16.4.2.1 eq.8-31)..... 68

Equation 13. Thrust control limit (*SSHB* 8.16.4.3 eq.8-37). 70

Equation 14. Vertical dead load, DL_v (ksf)..... 76

Equation 15. Self-weight of the culvert, SW (ksf) 76

Equation 16. Horizontal dead load at the top applied to the exterior walls of the culvert, DL_{hT} (ksf) 77

Equation 17. Horizontal dead load at the bottom applied to the exterior walls of the culvert, DL_{hB} (ksf) 77

Equation 18. Horizontal live load applied to the exterior walls, LL_h (ksf) 77

Equation 19. Vertical live load applied to the top slab, LL_{vT} (ksf). 79

Equation 20. Vertical live load applied to the bottom slab, LL_{vB} (ksf) 80

Equation 21. Total Load Case 87

Equation 22. Reduced Lateral Load Case 88

Equation 23. Vertical live load applied to the top soil mass for Level 3 analysis, LL_{vT} (klf)..... 95

1. INTRODUCTION

A. PURPOSE

The purpose of this *Culvert Rating Guide* is to present a clear, repeatable and valid procedure for Texas Department of Transportation (TxDOT) engineers and their consultants to use for load rating culverts in the TxDOT roadway system. Figure 1 provides an example of such a culvert.



FIG 1. Complex 7-span reinforced concrete box culvert; Nueces County, Corpus Christi District; original construction 1924, widened/ lengthened 1947; Structure #161780010202005.

Stated another way, the *Culvert Rating Guide* is intended to clarify policy assumptions, minimize procedural inconsistencies and resolve analytical variances associated with load rating which – left unattended – have been shown to accumulate and coalesce into a “disconnect” between observed structure performance and calculated load rating values. Fundamentally this *Guide* is about helping TxDOT achieve an acceptable level of culvert load rating accuracy and precision that avoids unnecessary restrictions on commerce such as may result from, on the one hand, unfounded (high) load ratings that lead to premature structure deterioration or failure or, on the other hand, unwarranted (low) ratings that lead to unnecessary structure replacements or upgrades.

B. WHAT’S NEW IN THE SECOND EDITION

This second edition of the *Culvert Rating Guide* reflects the authors’ experiences using the first edition and incorporates significant new research findings from recent studies which have both further developed the culvert load rating process and improved the accuracy and precision of the primary demand model used for culvert load rating analyses. Some topics in the original *Guide* have been condensed or eliminated, while others have been expanded or added. The most noteworthy changes are:

- We formally articulated the culvert load rating process and expressed this process as a series of seven steps. This was in recognition of the challenge faced by TxDOT engineers and consultants who are responsible for an entire roadway system (thousands of culvert structures) as opposed to isolated load rating efforts engendered by a particular project need (one culvert). This formalization of the load rating process required a major restructuring of the *Culvert Rating Guide* in both breadth and depth.

- We updated the discussion of policy guidance for culvert load rating to reflect current documents of technical authority at both the national and state levels.
- We retained the section on Level 1 load rating (2D structural frame model) as this is the default approach identified in American Association of State Highway and Transportation Officials (AASHTO) policy for calculating load demands. Level 1 uses CULV-5 software which is familiar to many TxDOT engineers, and it is suitable for quick, preliminary analyses. The discussion has been refined and includes a statement of both the benefits and limitations of the Level 1 model.
- We removed the section on Level 2 load rating (2D structural frame model supported by soil springs) as research has shown this modeling approach increased the work of load rating but did not improve the accuracy of the results.
- We extensively revised and expanded the section on Level 3 load rating (2D soil-structure interaction model). Changes include several model enhancements that dramatically improve the accuracy and precision of calculated load demands, as well as the introduction of new modeling features not previously available for Level 3. The Level 3 analysis is the approved model for load rating TxDOT culverts.
- We updated the discussion on how to perform culvert capacity calculations. In particular we expanded, clarified, and improved the guidance for interpreting TxDOT's multiple generations of culvert design standards.
- Most significantly, the *Culvert Rating Guide, Second Edition* is being issued in concert with CULVLR: Culvert Load Rating, Version 2.0 which is a Windows®-based desktop application software package that automates the process for performing load rating calculations for TxDOT's inventory of reinforced concrete box culverts. The CULVLR 2.0 software is available from the TxDOT Bridge Division, Austin, TX.

Research-driven improvements to the culvert load rating procedure, policy, practice and application over the past five years have essentially resulted in a complete rewrite of the original *Culvert Rating Guide*. While the topic is still load rating TxDOT culverts, the outcome is more accurate and precise load rating results.

C. DEFINITION

Load rating is a component of the bridge inspection process and consists of determining the live load carrying capacity of a bridge structure. As used in this *Guide*, multi-span box culverts are bridge-class provided the centerline length of all spans combined is greater than 20 feet (*Code of Federal Regulations 2016*). Load rating is used to determine whether specific legal or overweight vehicles can safely cross a bridge-class culvert, and to determine if the structure needs to be load-restricted and what level of posting is required.

Load ratings are based on the culvert's current condition and are determined through analysis and engineering judgment by comparing the culvert structure's capacity and dead load demand to live load demand. This yields a rating factor (RF) which, when multiplied by the tonnage of the rating vehicle (nominally 20 tons for the HS-20 standard truck) yields the load rating (RT). The load rating is expressed in terms of two separate thresholds – an Inventory Rating and an Operating Rating. The Inventory Rating (IR) is the maximum truck load that can safely utilize the bridge [or bridge-class culvert] for an

indefinite period of time (AASHTO 2011; TxDOT 2018). The Operating Rating (OR) is the absolute maximum permissible truck load that may use the bridge [bridge-class culvert].

D. TxDOT’S CULVERT POPULATION

National Bridge Inventory (NBI) data (Federal Highway Administration 2016) identify 136,971 bridge-class culverts out of a total of 611,845 highway bridges in the U.S., or 22 percent of the total inventory. These same data show that Texas possesses a total of 19,594 bridge-class culverts – by far the largest of any state – accounting for 14 percent of bridge-class culverts in the U.S. Further, 32 states record more than 1,000 culverts in their bridge inventory, with the proportion of culverts ranging from 3 to 55 percent (Federal Highway Administration 2016). In Texas, of 13,409 on-system bridge-class concrete culverts, 10,846 (81 percent) were built prior to 1980 (Figure 2).

NBI identifies ten types of materials for bridge-class culverts, with the primary types being concrete (67%) or continuous concrete (21%). While the load-rating factor equations per AASHTO are the same for all bridges, the calculation of load demands and section capacities used in these equations require that different material types and different culvert geometries be analyzed differently. Texas actually has a very consistent inventory, with 97 percent of Texas’ bridge-class culverts being cast-in-place reinforced concrete boxes.

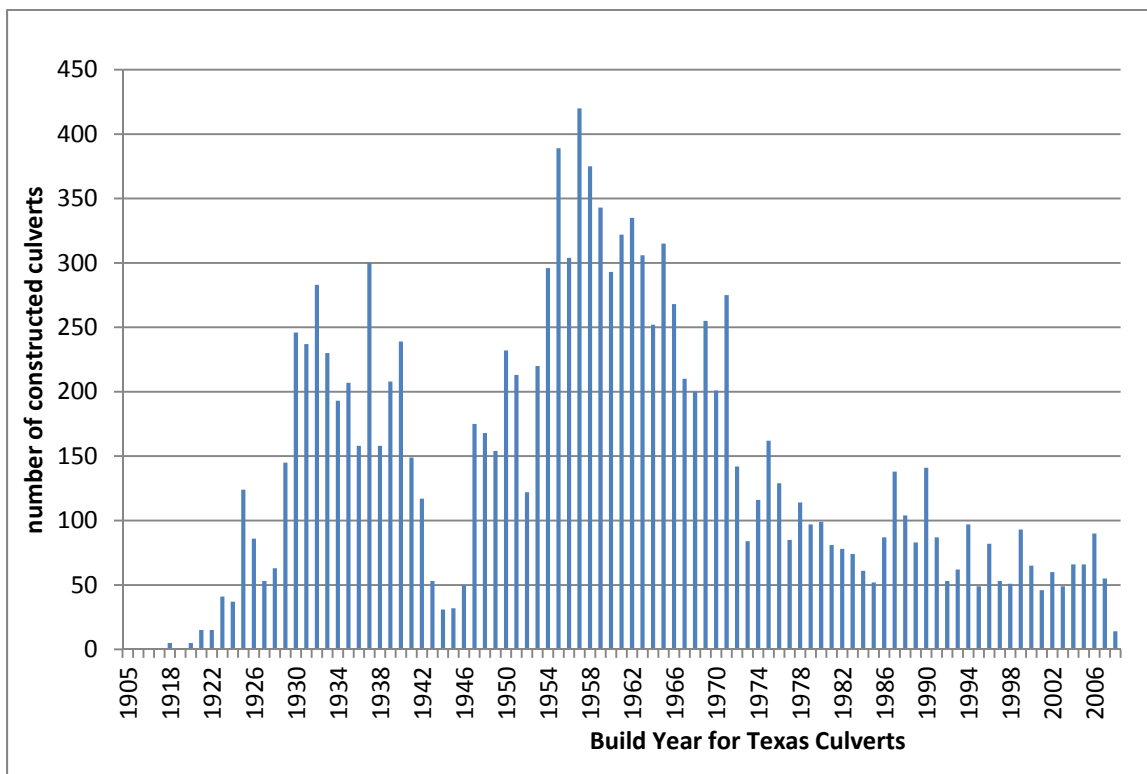

FIG 2. Build years for Texas culverts, with 81 percent constructed prior to 1980.

Culverts have a long service life, with NBI data identifying in-service culverts in the U.S. dating to 1900. Roughly one-third of Texas’ culverts were constructed in years leading up to and following World War II under an initiative to expand Texas’ farm-to-market road system entitled, “Get the farmer out of the mud” (Hagan 1991). About half of Texas’ culverts were constructed during the interstate highway era. In the late 1970s, TxDOT’s material specifications – in particular the widespread availability of Grade

60 reinforcing steel – had advanced such that all Texas culvert design standards were uniformly updated to handle HS-20 loading.

The implications of long culvert service life are many and include changing construction specifications (for the same materials!), changing design loads, changing design philosophy, and changing load-rating policy, to name a few. In particular it is important to note that during their long service lives, culverts are regularly upgraded to improve traffic capacity, hydraulic capacity, or both.

While the mental image of a culvert might be simple (a one-span or multi-span box), the construction of actual bridge-class culverts often gets quite complicated. These structures are widened (normal to the centerline) and in some cases lengthened (spans added), years or decades after the original culvert was built. These major culvert modifications are usually done under designs and specifications which differ from the original structure, and we introduce the term “segments” to describe the sequenced method of culvert construction. It turns out that about half of TxDOT’s older bridge-class culverts are comprised of more than one segment, with the typical number of segments being two. Thus, an approved load rating process must identify, define, and account for all unique segments of the culvert structure, and the principle of superposition requires that load rating calculations be performed for each and every culvert segment.

E. SCOPE

This *Culvert Rating Guide* focuses on reinforced concrete box culverts, this being the dominant culvert type used by TxDOT. The *Guide* is written to facilitate load rating for reinforced concrete box culverts from any design era, for any number of spans, for any culvert geometry, and for any range of backfill heights. That being said, this *Guide* gives priority treatment to TxDOT’s population of older structures (pre-1980) in terms of the load rating method, the presentation of TxDOT culvert design standards, and the discussion of material properties.

The procedures described herein specifically apply to load-rating in-service culverts with drained backfill conditions. It is assumed that culverts which are being load-rated will have had a visual inspection to establish the condition rating of the culvert.

This *Guide* includes limited information about load rating for alternative culvert structures with respect to shape (circular pipe, arch, etc.), material (aluminum, plastic, steel, etc.), backfill type, and drainage. While reinforced concrete boxes are typical and prevalent, the load-rating engineer will encounter alternative shapes – for example, three-sided structures or expansion slabs – and alternative materials – for example, pre-cast concrete. The guidance herein will help the engineer address such conditions indirectly.

F. A REASONABLE EXPECTATION OF SATISFACTORY PERFORMANCE

It is appropriate to identify a general idea, or mental model, of the level of performance of TxDOT culverts relative to both inspection results and load rating values. This provides the load rater with an overall context for the kinds of results that are typical for his or her load rating effort. To this end, the *Culvert Rating Guide, Second Edition* was developed based on findings from a series of research projects performed over the past ten years that were sponsored by TxDOT. The Level 3 production-simplified model that this *Guide* recommends for load rating was calibrated based on data from full-scale instrumented culvert load tests (Lawson et al 2010), and fine-tuned to optimize accuracy and precision of the predicted load demands through a series of parametric and other analytical studies (Lawson et al 2016; Lawson et al 2018).

In particular, the research studies selected a simple random sample of 1,000 culvert structures for analysis (termed 'Batch 1') from TxDOT's population of on-system, bridge-class, pre-1980, cast-in-place, reinforced concrete box culverts which numbered 10,829 structures in 2014. This was done to provide a statistically-representative sample from which valid inferences about TxDOT's entire culvert population could be drawn.

What level of performance is typical for TxDOT culvert structures? The culvert condition rating is an independent variable specific to the culvert structure because condition rating data are captured and reported only for culvert structures, not segments. Condition ratings are based on visual inspection of the culvert structure and characterize performance relative to NBI's established numerical scale. Low condition ratings (0 to 4) indicate failed to poor condition, middle ratings (5 to 6) indicate fair to satisfactory condition, and high ratings (7 to 9) indicate good to excellent condition. Refer to Figure 3.

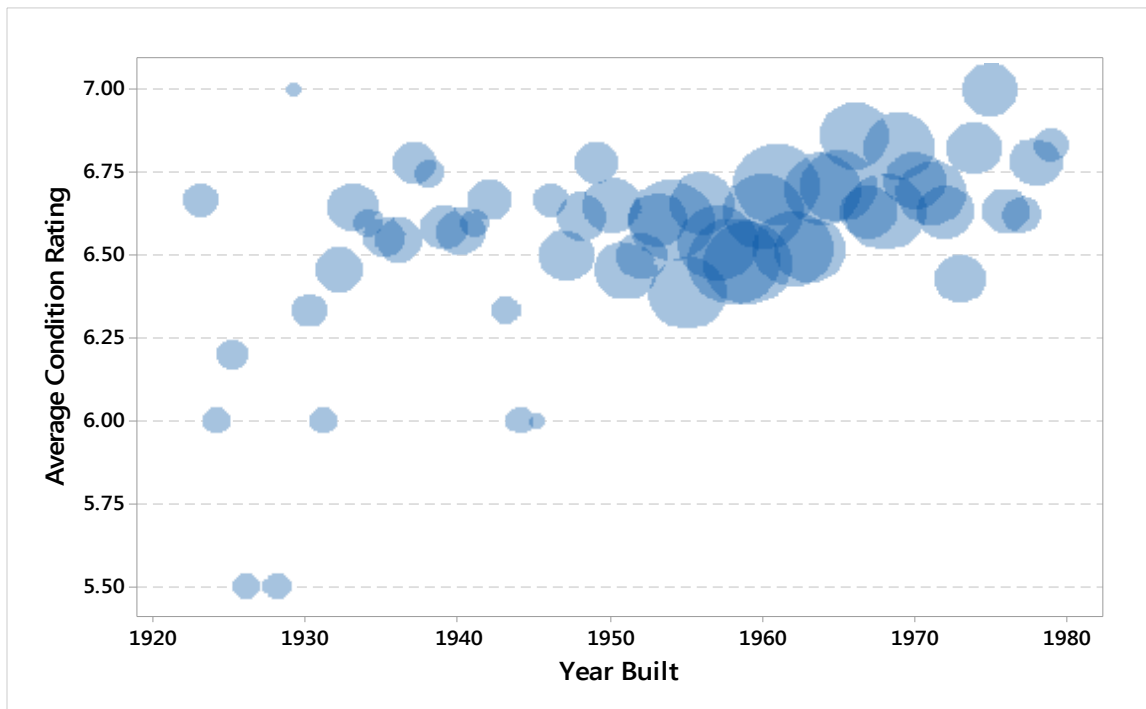

FIG 3. Culvert Inspection Condition Rating vs. Original Year Built (n = 998)

Figure 3 shows a bubble plot of condition rating vs. original year built (a surrogate for age), where the size of the bubble is proportional to the sample size for each year. The dataset for this analysis excluded one culvert with no condition rating assigned, and one structure that was entirely post-1979. The reported condition rating for TxDOT culvert structures ranges from 4/9 to 8/9, with most culverts (63% \pm 2.9%) scoring 7/9 or better.

What about numerical load rating values, which are the specific focus of this *Guide*? As has been noted, load rating computations are performed at the *segment* level, and the lowest rating from all segments that make up a culvert is the *controlling* load rating for the structure. Figure 4 presents summary results and analysis of Level 3 load rating computations for the segments associated with the 1,000 Batch 1 culvert structures evaluated in the load rating research studies. Findings are aggregated into customary load-posting categories.

Figure 4 focuses only on those segments for which load-rating calculations were performed, a total of 1,385/1,788 segments. This figure excludes all categories of segments that were not load rated for various reasons. Among the rated culvert segments, 91% ($\pm 1.7\%$) have a Level 3 inventory rating IR \geq HS20 (dark green color) or a Level 3 operating rating OR \geq HS20 (light green color).

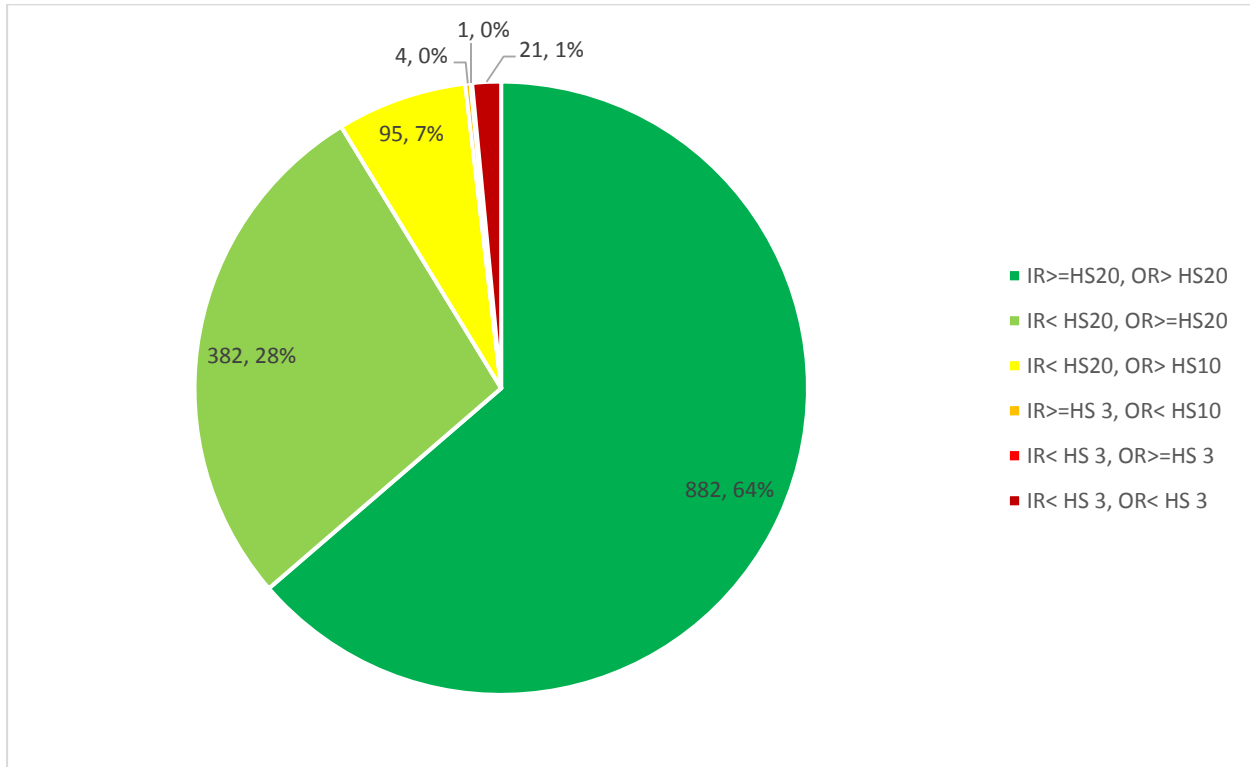

FIG 4. Load Rating Results for Load Rated Segments ($n = 1,385$)

The remaining culvert segments total 9% ($\pm 1.7\%$) and consist of culvert segments with Level 3 operating ratings (OR) at varying degrees *below* HS20, represented by the other colors, *i.e.*, yellow, orange, red and maroon. Here it is significant to note that most segments in this group (7% $\pm 1.5\%$) rate “in the yellow” and thus are relatively close to achieving a Level 3 OR \geq HS20 such that posting would not be required. Given that the structural condition ratings for TxDOT’s culverts generally indicate good performance, such segments are reasonable candidates for further analysis using more sophisticated demand models and with project-specific structural and soil properties, the goal being to determine whether such segments actually rate more in line with their performance, *i.e.* possess an OR \geq HS20.

It is important to note that only 2% ($\pm 0.8\%$) of rated culvert segments show Level 3 ratings (OR) *below* HS10, represented by the orange, red and maroon colors. These would be the group most subject to consideration for load posting, rehabilitation, or other action.

Collectively then, the research findings which undergird the second edition of the *Culvert Rating Guide* suggest that load rating engineers who follow and apply the procedures in the *Guide* may regularly expect to determine load ratings indicative of “good” to “very good” culvert performance. Such load rating values are fully consistent with structure performance that has been independently observed in the field and should not be considered a fluke. Obviously the full range of outcomes is possible and each culvert structure must tell its own story.

G. RATING PHILOSOPHY

Load ratings are determined by comparing the culvert capacity and dead load demand to the live load demand. Thus, the culvert load rating is strongly dependent on how culvert capacity, culvert dead load, and culvert live load are established.

Typical practice is to determine culvert capacity based on the details found on the original construction documents in combination with historical material property assumptions which are correlated by visual inspection of the culvert condition. The dead and live load demands on the structure are determined by analytical modeling. This means that the culvert load rating process requires engineering decisions about modeling practices and procedures, as well as the knowledgeable evaluation and selection of numerous parameters and variables.

TxDOT policy provides guidance for many aspects of culvert load rating. TxDOT's official policy concerning culvert load rating is published in the *TxDOT Bridge Inspection Manual* (TxDOT 2018) which in turn relies upon the *AASHTO Manual for Bridge Evaluation, 2nd Edition (MBE)* (AASHTO 2011) and other documents.

Other aspects of the culvert load rating process are not directly addressed by policy, one example being selection of the analytical model for determining dead load and live load demands. Modeling can be approached in many ways, with each analytical method requiring its own degree of effort and yielding results that predict actual load demands with varying degrees of accuracy.

Recognizing the range of culvert modeling alternatives available, to promote efficiency this *Guide* advocates "production simplified" modeling. That is, analytical, parametric and other modeling decisions are approached with an emphasis on production (*i.e.*, allowing simplifying assumptions within the bounds of reasonable accuracy and expediency) rather than analytical sophistication (*i.e.*, imposing the strictest modeling rigor).

To this end, the *Culvert Rating Guide* identifies three analytical models of increasing complexity, allowing for cost vs. performance (or effort vs. accuracy) trade-offs. The first level (Level 1) is a "quick" calculation using a stylized two dimensional frame model. The next level (Level 3) uses a two dimensional finite element model that considers soil-structure interaction effects. That is, both the culvert and the soil surrounding the culvert structure are modeled with finite elements. With the guidance presented herein and an appropriate software package, any structural engineer should be able to confidently load rate a culvert using these levels.

The next level (Level 4) is the general case. Here, applications are open-ended and highly project-specific, and use is restricted to research or specialized applications. Level 4 assumes the use of more complex, two or three-dimensional finite element models with soil-structure interaction. The selection of modeling approach, model details, rating parameters and calibration requirements will be individualized and largely left to the discretion of the engineer rating the culvert.

H. ABOUT THIS GUIDE

It is the intent of the *Culvert Rating Guide, Second Edition* to assemble, summarize and clarify the necessary information for culvert load rating, both that portion specifically addressed by policy and that portion which is not, for each level of analysis. The chapters are as follows:

Chapter 1 provides an introduction and background to culvert load rating at TxDOT.

Chapter 2 is devoted to culvert rating policy. This chapter identifies the governing policy associated with culvert load rating, and summarizes applicable policy guidance.

Chapter 3 outlines the culvert rating procedure. Whereas the first two chapters provide pertinent background information, this chapter lays out how culverts should be load rated at TxDOT. This includes a flow chart which summarizes the culvert rating process.

Chapter 4 presents the initial step for load rating a culvert. Beginning with culvert plans, construction details, and other information, this chapter shows how to obtain and classify the necessary documents needed for culvert load rating.

Chapter 5 presents the second step for load rating a culvert, which is to establish the history of the culvert structure and to interpret its design/ construction sequence in terms of one or more culvert segments.

Chapter 6 presents the third load rating step. This is performed for each culvert segment as opposed to the first two steps which are performed for the culvert structure as a whole. In Step 3, the load rating engineer must interpret and identify all parameters required to create a culvert analytical model including site variables, segment geometry, and others.

Chapter 7 presents the fourth step for culvert load rating, also performed at the segment level, which focuses on identifying and parameterizing the specific design used to construct the culvert segment.

Chapter 8 discusses culvert capacity calculations. For culvert load rating, capacity is based on equations and approaches specified in AASHTO policy. This chapter presents both the policy and a straightforward approach for determining culvert capacity to facilitate the load rating calculation.

Chapter 9 and 10 present the Level 1 and Level 3 analytical modeling approaches, respectively. These models are used to determine demand loads necessary for culvert load rating calculations. The discussion addresses the assumptions associated with each modeling level, specification of the analytical model, assigning boundary conditions, and defining and applying dead load and live loads. These chapters also discuss available structural analysis software commonly used by TxDOT for each level. Finally, each chapter presents a detailed, step-by-step procedure for calculating demand loads with specific reference to the CULVLR 2.0 software package.

Chapter 11 discusses specialized approaches for load rating culverts, including Level 4 analytical modeling and performing field load tests. The chapter includes generalized guidance about applications, modeling approaches, software selection, and procedures.

Chapter 12 discusses limitations associated with use of this *Guide*. These include culvert type, deep fill culverts, submerged culverts, saturated soils and backfill soil modulus values.

This *Guide* includes six appendices. Appendix A presents an example of how to accomplish the first step in culvert rating; that is, obtaining and classifying the culvert documentation. Appendix B continues this example, explaining how to establish the culvert history and interpret its design segments. Appendices C through F continue the example by presenting how to obtain parameters, select the culvert design, perform demand load calculations and culvert load rating based on Level 1 and Level 3 modeling approaches, and report the results.

2. POLICY REQUIREMENTS

A. POLICY SOURCE DOCUMENTS

The load rating guidance presented in the *Culvert Rating Guide* supports TxDOT's efforts to comply with federal regulations for bridge inspection per 23 CFR 650 Subpart C, *National Bridge Inspection Standards* (Code of Federal Regulations 2016). Many standards, manuals, and technical advisories have been developed for bridge inspection and load rating.

For TxDOT, the major publications which refer to culvert rating and design are:

- TxDOT. (2018). *Bridge Inspection Manual*. Austin, TX: Texas Department of Transportation. (TxDOT 2018)
- TxDOT. (2015). *Bridge Design Manual (LRFD)*. Austin, TX: Texas Department of Transportation. (TxDOT 2015)

It is TxDOT's policy to satisfy the current AASHTO requirements; however, in some instances the AASHTO requirements do not provide necessary information or TxDOT has identified its own specific guidance. These situations will be noted as they occur, but the general case is that AASHTO policy provides the controlling framework for culvert load rating.

At the national level (FHWA and AASHTO), the major publications are:

- AASHTO. (2016). *Manual for Bridge Evaluation (MBE), Second Edition., with 2011, 2013, 2014, 2015 and 2016 Interim Revisions*. Washington D.C.: American Association of State Highway and Transportation Officials, Inc. (AASHTO 2016).
- AASHTO. (2014). *LRFD Bridge Design Specifications, U.S. Customary Units, 7th Edition (LRFD7)*. Washington, D.C.: American Association of State Highway and Transportation Officials. (AASHTO 2014)
- AASHTO. (2002). *Standard Specifications for Highway Bridges (SSHB), Seventeenth Edition*. Washington, D.C.: American Association of State Highway and Transportation Officials. (AASHTO 2002)

FHWA also maintains an extensive load rating web page, <https://www.fhwa.dot.gov/bridge/loadrating/>. This page provides links to load rating regulation, policy, guidance, research and publications, training courses, webinars, and related information.

The *Culvert Rating Guide* was informed by and is substantially aligned with such policy. AASHTO's *MBE* provides technical guidance, the actual rating equations, load factors and material property assumptions. AASHTO's *Standard Specifications for Highway Bridges 17th Edition* provides guidance associated with the simplified direct stiffness (Level 1) analysis approach including dead and live load values and distributions, strength reduction factors and capacity calculations. AASHTO's *LRFD 7th Edition* provides additional guidance for basic rating parameters which have been used for some aspects of the soil structure interaction approach (Level 3).

The following sections of this document outline and interpret the AASHTO policy requirements for culvert load rating at TxDOT.

B. LOAD FACTOR RATING (LFR)

The AASHTO *MBE*, Section 6, provides technical guidance on load rating and posting of existing bridges and identifies three methods for load rating: load and resistance factor rating (LRFR), load factor rating (LFR), and allowable stress rating (ASR). Per the *MBE*, “No preference is placed on any rating method. Any of these three methods... may be used... for purposes of load posting”. The *MBE* Section 6, Part A presents LRFR procedures for load rating bridges consistent with the load and resistance factor design philosophy. The *MBE* Section 6, Part B provides a choice of procedures for load rating bridges using either ASR or LFR. Both approaches accommodate two rating levels, the inventory rating level (IR) associated with the design capacity and operating rating level (OR) associated with the ultimate capacity.

Technical guidance for load rating primarily is written with traditional bridges in mind, although significant portions of this policy can be extrapolated to bridge-class culverts. The *MBE* Section 6 does not specifically mention culverts, neither Part A nor Part B. However, the 2013 Interim Revisions to the *MBE* add a completely new article, Section 6A.4.12, on rating of reinforced concrete box culverts using the LRFR method. Further, the 2014 Interim Revisions to the *MBE* provide additional guidance on live loads for LRFR rating of culverts. In contrast, the *MBE* Section 6B (ASR, LFR) does not currently provide any specific load rating guidance for culverts apart from brief statements in the 2016 Interim Revisions on assigned load ratings and on potential overconservatism associated with simplified modeling approaches.

TxDOT policy on load rating as stated in Chapter 8, Section 5 of the *Bridge Inspection Manual* is as follows:

Calculations for On-System Bridges

- “Perform all load rating calculations for on-system bridges not designed using Load and Resistance Factor Design (LRFD) using the "Load Factor" method as illustrated in AASHTO’s *Manual for Bridge Evaluation* with no exceptions.”
- “Load rate on-system bridges designed by LRFD using the Load and Resistance Factor Rating (LRFR) method as illustrated in *AASHTO’s Manual for Bridge Evaluation*.”

Calculations for Off-System Bridges

- “Provide bridge load rating calculations in accordance with the State’s bridge inspection policy. Either Working-Stress or Load Factor analysis is acceptable.”

Inasmuch as the *Culvert Rating Guide* gives priority to the rating of TxDOT’s population of older bridge-class culvert structures, primarily on-system and not designed using LRFD, the LFR method is also given priority and is extensively discussed herein.

Load rating engineers who are interested in the rating of newer culvert structures designed using LRFD will find some help in this *Guide*, but mainly are directed to the *MBE*’s extensive guidance and commentary for the LRFR approach.

C. LOAD RATING VEHICLE LOAD PATTERNS

The *MBE*, Section 6A (pertaining to LRFR), identifies three purposes for bridge evaluation, each using different live load models and evaluation criteria. These are design load rating (for the strength limit state under the LRFD design level of reliability), legal load rating (for a given truck configuration

applicable to AASHTO and State legal loads), and permit load rating (for evaluation of vehicles above the legally-established weight limitations).

The *MBE*, Section 6B (which directly pertains to LFR which is the focus of this *Guide*), provides similar guidance and requires that load ratings be performed at two levels – inventory and operating – for three live load models which are design, posting and permitting. The design load rating evaluates culvert strength. The posting load rating evaluates the culvert under various legal loads, and the permit load rating evaluates the culvert based on the actual vehicle size, weight and type using the highway.

TxDOT’s *Bridge Inspection Manual*, Chapter 5, discusses TxDOT’s policy for design load ratings and legal load ratings, and Chapter 6 discusses permit load ratings. Relative to the *Culvert Rating Guide*, the load rating engineer is responsible to determine the purpose for which the load rating is being performed. Any of the three stated purposes may apply.

For LFR (which is the typical case), both the design load *and* the state legal load are equivalent to the HS-20 load pattern shown in Figure 5. This is true nationally (*MBE* Section 6.B.6.2) and in Texas (*Bridge Inspection Manual*, Chapter 5, Section 3 and Section 4). The standard HS-20 truck was introduced in the 1940s to represent an idealized tractor-semi-trailer combination (Kulicki and Mertz 2006). First identified in 1944, the HS-20 truck features three axles and a total weight of 72,000 lbs.

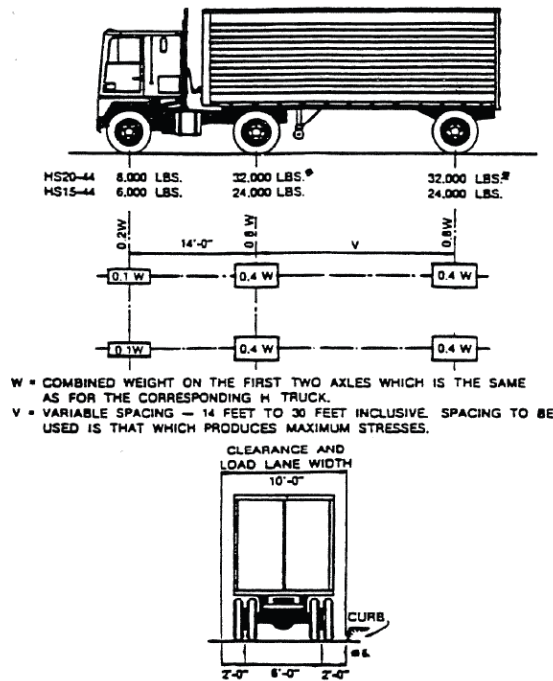

FIG 5. Standard HS-20 Truck. From *AASHTO Manual for Bridge Evaluation, 2nd Edition*, Copyright 2016, by the American Association of State Highway and Transportation Officials, Washington, DC. Used by permission.

The load rating procedures presented in this *Guide* accommodate not only the HS-20 load pattern, but also alternative vehicle load patterns such as the AASHTO legal load patterns, specialized hauling vehicles, HL-93 load pattern, and others. Figure 6 identifies these alternative vehicle load patterns.

The AASHTO legal loads are a set of three vehicle configurations (Fig 6.a) identified in the 1980s that were found to be typical of the legal load trucks operating in many states (Committee for the Truck Weight Study 1990). AASHTO Type 3 is representative of a three-axle, single unit truck. Type 3S2 is

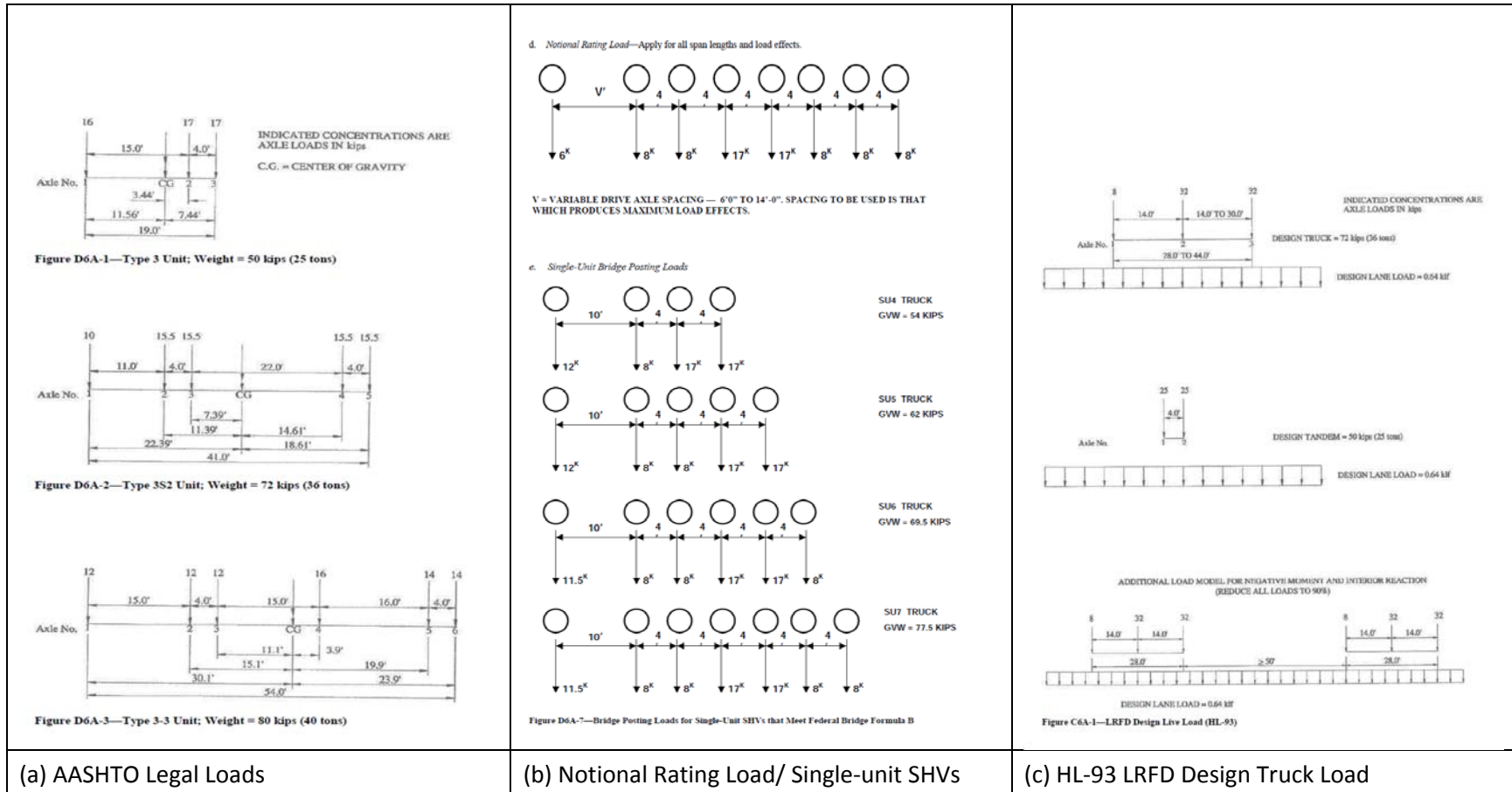

FIG 6. Live load models identified in the AASHTO MBE. From *AASHTO Manual for Bridge Evaluation, 2nd Edition*, Copyright 2011, by the American Association of State Highway and Transportation Officials, Washington, DC. Used by permission.

representative of a five-axle tractor-semitrailer, *i.e.*, the common “18-wheeler.” Type 3-3 is representative of a six-axle truck-trailer combination. The *MBE* Part 6A specifies that the AASHTO legal loads be used for LRFR rating of bridges for routine legal commercial traffic, with the ratings suitable for use as a basis for decision-making related to load-posting or bridge strengthening. Similarly, the *MBE* Part 6B specifies the AASHTO legal loads to be used for LFR or ASR rating for bridge posting considerations.

The third truck load group, SHVs, represent a class of legal vehicles not initially incorporated within the set of typical AASHTO legal loads, and thus require special consideration for load rating/posting decisions (Sivakumar et al. 2007). Figure 6.b identifies the notional rating load (NRL) that is considered as a screening load model for single-unit trucks that meet Formula B. Also included are four single-unit Formula B legal loads that represent the worst four-axle (SU4), worst five-axle (SU5), worst six-axle (SU6) and worst seven-axle (SU7) trucks identified for this group. The *MBE* Part 6A specifies that the NRL/ SHV loads be used in addition to the AASHTO legal loads for LRFR ratings suitable for bridge posting considerations. Likewise, the *MBE* Part 6B also specifies the NRL/ SHV loads be used for LFR or ASR ratings associated with bridge posting.

The final live load model, the HL-93 design live load (Fig 6.c), is a family of three live load models adopted for use in the LRFD design of bridges. The first – identified as “Design Truck” – is none other than the standard HS-20 truck, discussed previously. The second HL-93 load – identified as “Design Tandem” – generally corresponds to what had previously been identified as “alternate military loading”. The third HL-93 load depicts a train of two HS-20 trucks spaced at least 50ft apart with loads reduced to 90%. This HL-93 family of loads was found to best fit the exclusion vehicles of the Interstate design era and thus served as the basis for a new live load model that would achieve more uniform and consistent safety of bridges (Kulicki and Mertz 2006). The *MBE* Part 6A specifies that the HL-93 family of loads be used for the design load rating of bridges. The *MBE* Part 6B does not mention HL-93 loads other than a statement in the 2016 Interim Revisions that bridges having an HL-93 operating rating factor greater than 1.0 need not be rated for SHVs.

In addition to live-load configuration, the *MBE* Section 6A addresses other aspects of bridge live load including dynamic load allowance, lane load models, multiple presence probabilities, and calibrated live load factors for a variety of conditions associated with the LRFR rating method. Likewise, the *MBE* Section 6B addresses these aspects for ASR and LFR. This technical guidance may be said to directly apply to bridges proper, and the *MBE* commentary makes a point to say that “specifications are calibrated documents in which the loads, load factors and design methods are part of the whole and should not be separated”. The *MBE*’s treatment of these other aspects of load rating specific to culverts primarily exists in the 2013 Interim Revisions for LRFR rating of culverts (Section 6A). The *MBE* Section 6B does not provide this same guidance for the LFR and ASR rating methods.

D. LOAD RATING EQUATION

The rating equation summarizes the principles of load rating under the LFR method, Equation 1. The rating factor, RF , is essentially a live load factor of safety for a particular section in a structure calculated from the capacity, C , minus the factored dead load, A_1D , and divided by the factored live load including impact, $A_2L(1 + I)$.

EQ 1. THE RATING FACTOR EQUATION (*MBE* 6B.4.1-1).

$$RF = \frac{C - A_1D}{A_2L(1 + I)}$$

where: RF = the rating factor

C = the structural capacity of the member

D = the dead load effect on the member

L = the live load effect on the member

I = the impact factor, IM from *SSHB* 3.8.2.3

$A_1 = 1.3$ = factor for dead loads, from *MBE* 6.B.4.3

$A_2 = 2.17$ for Inventory Level = factor for live loads, from *MBE* 6.B.4.3

= 1.3 for Operating Level = factor for live loads, from *MBE* 6.B.4.3

This equation is applied for multiple “critical” sections of the culvert structure (refer to the next article in this chapter). If the rating factor is greater than 1.0, the section can carry the applied live load at that section; if less than 1.0, the section does not have adequate capacity. The lowest rating from all sections governs the load rating for the structure.

Once the controlling (lowest) rating factors for the inventory and operating conditions are calculated, the inventory and operating load rating can be determined by multiplying the rating factor by the HS rating truck tractor tonnage as seen in Equation 2.

EQ 2. THE LOAD RATING EQUATION (*MBE* 6B.4.1-2):

$$RT = RF * W$$

where: RT = the load rating in terms of an HS truck tonnage

RF = the rating factor from Equation 1

W = the HS truck tractor tonnage; for HS-20, $W = 20$ tons

Note that the variables used in Equation 2 are specific to HS-20 loading as per TxDOT policy. This means that the load rating (RT) will be expressed in terms of an HS-designation rather than the gross weight of the vehicle. In cases where alternative vehicle loads are used, the rating factors (inventory – IRF and operating – ORF) and not the load rating, are identified.

E. CRITICAL SECTIONS

Culvert structures are often modeled in two dimensions by assuming plane strain conditions and taking a one-unit-wide “slice” normal to the culvert flowline as shown in Figure 7. Several cross sections from this slice must be analyzed for both capacity and demand in order to establish the load rating for a culvert structure. Multiple load ratings must be calculated, with the lowest load rating from all cross sections becoming the culvert load rating.

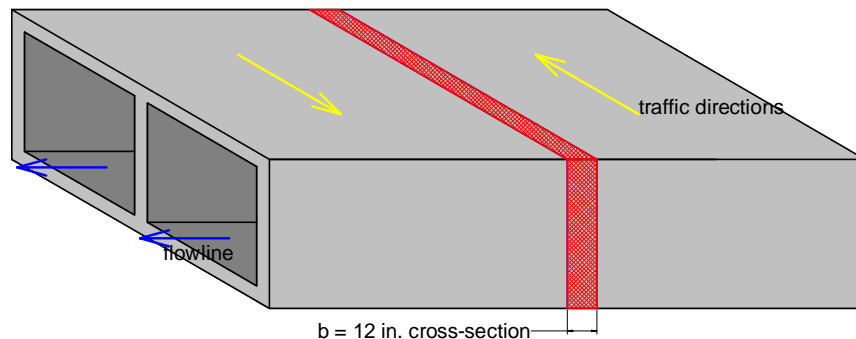

FIG 7. Three Dimensional View of a Culvert Indicating Two-Dimensional (Plane Strain) Unit Strip.

Experience suggests that the controlling location for culvert load rating, known as the critical section, will typically be either near mid-span or at a corner of the culvert structure cells. According to the *SSHB* Section 16.6.4.5, the corner capacity and demand for moment may be taken “at the intersection of the haunch and uniform depth member.” In the case of culverts without haunches, it is taken at the face of the wall section. Figure 8 summarizes the critical section locations for culvert load rating for culverts without haunches (Fig. 8a) and culverts with haunches (Fig. 8b).

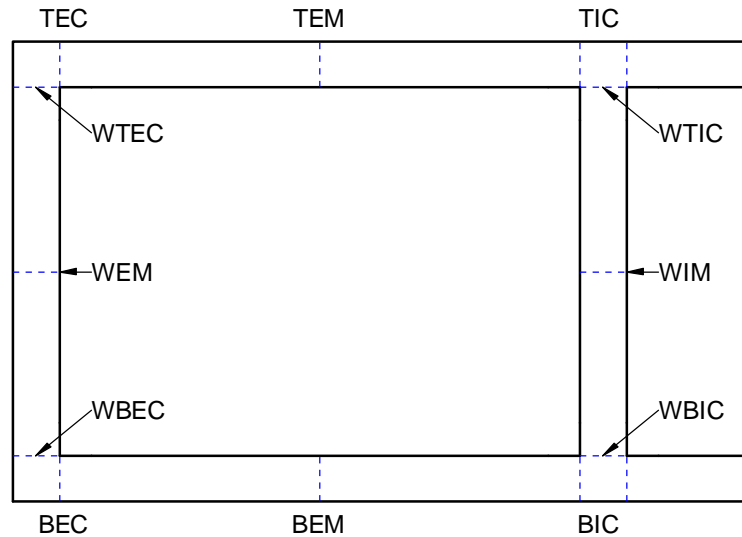

FIG 8(a). Moment Critical Sections for Culverts without Haunches.

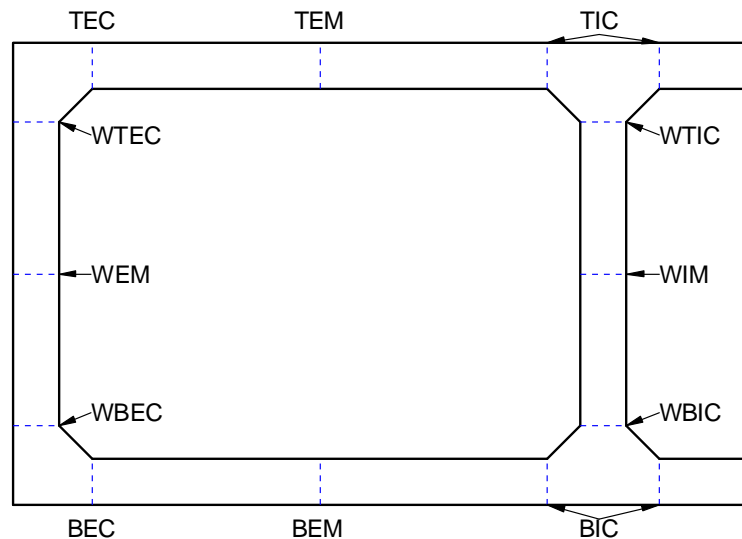

FIG 8(b). Moment Critical Sections for Culverts with Haunches.

Abbreviations for the typical critical sections shown in Figure 8, listed clockwise, are: top exterior corner (TEC), top exterior mid-span (TEM), top interior corner (TIC), top interior mid-span (TIM) – *not shown*, wall top interior corner (WTIC), wall interior mid-span (WIM), wall bottom interior corner (WBIC), bottom interior mid-span (BIM) – *not shown*, bottom interior corner (BIC), bottom exterior mid-span (BEM), bottom exterior corner (BEC), wall bottom exterior corner (WBEC), wall exterior mid-span

(WEM), and wall top exterior corner (WTEC). For multiple-span box culverts, the sections are designated as per the culvert span; e.g., TIC1, TIC2, BIC1, BIC2, etc.

The mid-span capacity and demand may, for convenience, be taken *at mid-span* for both top and bottom slabs and vertical walls. Technically, the analysis should identify the actual locations with the highest demand, but the error introduced by assuming the mid-span location is not significant.

Also, it is important to note that the corner critical sections shown in Figure 8 correspond to desired locations for the calculation of bending moment capacity and demand, as opposed to shear. Bending moment is the most common controlling failure mode for culvert load rating, so it is standard practice to use the moment critical sections for all three potential failure modes (moment, shear, axial), at least initially. This is a conservative approach when bending moment controls the rating, and it requires the least amount of effort. However, shear sometimes controls or appears to control the load rating. Chapter 9, Section C discusses the situation where shear appears to control the load rating, and provides AASHTO policy guidance on how to evaluate shear capacity and demand in that instance.

F. FAILURE MODES

The MBE 6B.5.3 states that nominal capacity of reinforced concrete should be the same as specified in the load factor sections of the SSHB. The SSHB, Section 8.16, defines three potential failure modes for concrete structural members designed in accordance with the strength design method. These are bending moment (or flexure), shear, and axial thrust. Culvert load rating calculations must consider all three failure modes, though typically, bending moment is the controlling case.

G. POLICY RATING VARIABLES – LEVEL 1 (2D STRUCTURAL FRAME)

The Level 1 load rating method described in this *Guide* is a simplified approach where load demands are calculated based on a 2D structural frame model for which AASHTO policy provides many of the rating parameters. Table 1 summarizes the basic rating variables specified for the Level 1 method. These variables provide guidance for both the demand and the capacity calculations.

TABLE 1. Culvert Load Rating Variables for Level 1 Load Rating as per AASHTO Policy

<i>Description</i>	<i>Value</i>	<i>Policy Section</i>								
Demand Variables										
<i>Rating Equation</i>	See Equation 1, <i>Culvert Rating Guide</i>	MBE 6B.4.1-1								
<i>Rating Live Load (Design)</i>	HS-20 Standard Truck	MBE 6B.6.2 SSHB 3.7.6								
<i>Lane Load</i>	Not used	MBE 6B.6.2								
<i>Multiple Presence Factors</i>	Not used	Not specified in MBE 6B								
<i>Impact Factor/ Dynamic Load Allowance</i>	<table border="0"> <tr> <td>0 < D < 1'</td> <td>IM = 30%</td> </tr> <tr> <td>1' < D < 2'</td> <td>IM = 20%</td> </tr> <tr> <td>2' < D < 3'</td> <td>IM = 10%</td> </tr> <tr> <td>3' < D</td> <td>IM = 0%</td> </tr> </table>	0 < D < 1'	IM = 30%	1' < D < 2'	IM = 20%	2' < D < 3'	IM = 10%	3' < D	IM = 0%	MBE 6B.6.4 SSHB 3.8.2.3
0 < D < 1'	IM = 30%									
1' < D < 2'	IM = 20%									
2' < D < 3'	IM = 10%									
3' < D	IM = 0%									
<i>Reduction in Load Intensity</i>	<table border="0"> <tr> <td>1 or 2 lanes</td> <td>100% of LL</td> </tr> <tr> <td>3 lanes</td> <td>90% of LL</td> </tr> <tr> <td>4 lanes</td> <td>75% of LL</td> </tr> </table>	1 or 2 lanes	100% of LL	3 lanes	90% of LL	4 lanes	75% of LL	SSHB 3.12.1		
1 or 2 lanes	100% of LL									
3 lanes	90% of LL									
4 lanes	75% of LL									

TABLE 2. Culvert Load Rating Variables for Level 1 Load Rating as per AASHTO Policy, continued

<i>Description</i>	<i>Value</i>	<i>Policy Section</i>
<i>Near-Structure Lateral Live Load for Traffic</i>	Additional 2 feet of surcharge to lateral load	<i>SSHB 3.20.3</i>
<i>Vertical Earth Pressure</i>	Calculate based on total unit weight for soil of 120 pcf	<i>SSHB 6.2.1.B</i>
<i>Lateral Earth Pressure – Corner Moment</i>	Calculate based on equivalent fluid weight for soil of 60 pcf	<i>SSHB 6.2.1.B, 3.20.2</i>
<i>Lateral Earth Pressure – Positive Moment</i>	Calculate based on equivalent fluid weight for soil of 30 pcf	<i>SSHB 6.2.1.B, 3.20.2</i>
<i>Live Load Distribution to the Top Slab (fill depth, D < 2')</i>	Wheel load (point load)	<i>SSHB 6.4, 3.24</i>
<i>Live Load Distribution to the Top Slab (fill depth, D > 2')</i>	Wheel load (point load) distributed over a square area 1.75D × 1.75D; overlapping areas are averaged	<i>SSHB 6.4</i>
<i>Live Load Distribution to the Bottom Slab</i>	Wheel load (point load) distributed over a rectangle area 1.75D × 1.75D + 2H	<i>SSHB 16.6.4.3</i>
Capacity Variables		
<i>Shear Strength Reduction Factor</i>	$\phi = .85$	<i>MBE 6B.5.3 SSHB 16.6.4.6</i>
<i>Combined Flexure and Thrust Strength Reduction Factor</i>	$\phi = .9$	<i>MBE 6B.5.3 SSHB 16.6.4.6</i>
<i>Assumed Concrete Strength, f'_c</i>	Unknown, prior to 1959... 2,500 psi Unknown, 1959 and after 3,000 psi	<i>MBE 6B.5.2.4-1 SSHB 8.16</i>
<i>Assumed Reinforcing Steel Strength, F_y</i>	Unknown prior to 1954 33 ksi Structural Grade 36 ksi Billet Grade (Gr.40) 40 ksi Unknown 1954 and after 40 ksi Rail Grade (Gr. 50) 50 ksi Grade 60 60 ksi	<i>MBE 6B.5.3.2 SSHB 8.16</i>

Where:

- D is the depth of fill
- IM is the impact factor
- LL is the live load.

The *SSHB*, Article 3.20.2, requires that two demand analyses must be made to determine the worst case loading condition for the culvert structure. These are the “total” load case and the “reduced lateral” load case. The total load case is designed to generate the maximum shear and axial demands in the whole culvert and the maximum moment demands in all but the top and bottom mid-spans. The reduced lateral load case is intended to generate the maximum moment demands in the top and bottom mid-spans. The load rater defines these load cases by combining basic dead and live loads differently. Chapter 9, Section D.7, provides detailed guidance about these load cases.

The *MBE*, Article C6B.7.1 notes that this simplified modeling approach (*i.e.*, Level 1) tends to produce conservative force demands, so “it is not uncommon to observe satisfactory performance of in-service culverts even when analytical ratings may show insufficient capacity for normal traffic.”

H. POLICY RATING VARIABLES – LEVEL 3 (2D SOIL-STRUCTURE INTERACTION)

The Level 3 load rating method described in this *Guide* is based on a 2D soil-structure interaction model for which AASHTO policy is silent on many of the rating parameters. Table 2 summarizes the basic rating variables specified for the Level 3 method. These variables provide guidance for both the demand and the capacity calculations.

TABLE 2. Culvert Load Rating Variables for Level 3 Load Rating as per AASHTO Policy

<i>Description</i>	<i>Value</i>	<i>Policy Section</i>
Demand Variables		
<i>Rating Equation</i>	See Equation 1, <i>Culvert Rating Guide</i>	MBE 6B.4.1-1
<i>Rating Live Load (Design)</i>	HS-20 Standard Truck	MBE 6B.6.2 SSHB 3.7.6
<i>Lane Load</i>	Not used	MBE 6B.6.2
<i>Multiple Presence Factors</i>	Not used	Not specified in MBE 6B
<i>Dynamic Load Allowance/ Impact Factor</i>	$IM = 33 (1.0 - 0.125 D_E) \geq 0\%$ where D_E is minimum depth of earth cover above the structure	MBE 6A.2.3.3 LRFD7 3.6.2.2, 12
<i>Reduction in Load Intensity</i>	Not used	SSHB 3.12.1
<i>Vertical Earth Pressure</i>	Calculate based on total unit weight for soil of 120 pcf	SSHB 6.2.1.B
<i>Live Load Distribution- In Plane Traffic Parallel to the Culvert Span</i>	Wheel load distributed on tire patch 10in long \times 20 in wide applied at ground surface (top of pavement); stress distributed through finite element mesh (numerical approximation of elastic solution)	LRFD7 3.6.1.2.6b
<i>Live Load Distribution- Out of Plane</i>	Wheel load distributed on tire patch 10in long \times 20 in wide; stress distributed with depth over a rectangular prism, 1.15D \times 1.15D	LRFD7 3.6.1.2.6a
Capacity Variables		
<i>Shear Strength Reduction Factor</i>	$\phi = .85$	MBE 6B.5.3 SSHB 16.6.4.6
<i>Combined Flexure and Thrust Strength Reduction Factor</i>	$\phi = .9$	MBE 6B.5.3 SSHB 16.6.4.6
<i>Assumed Concrete Strength, f'_c</i>	Unknown, prior to 1959 2,500 psi Unknown, 1959 and after 3,000 psi	MBE 6B.5.2.4-1 SSHB 8.16
<i>Assumed Reinforcing Steel Strength, F_y</i>	Unknown prior to 1954 33 ksi Structural Grade 36 ksi Billet Grade (Gr.40) 40 ksi Unknown 1954 and after 40 ksi Rail Grade (Gr. 50) 50 ksi Grade 60 60 ksi	MBE 6B.5.3.2 SSHB 8.16

Where:

- D is the depth of fill
- IM is the impact factor
- LL is the live load.

As has been noted, the Level 3 load rating approach is offered in an effort to overcome excess conservatism inherent in the simpler and quicker Level 1 approach. Authority for Level 3 may be found in the *MBE*, Article 6A.5.12.3 which states that demand analysis of box culverts may be based on “any rational method acceptable to the Owner.” The commentary on this article further notes that “where needed to verify higher load capacity, analytical models of increasing complexity and sophistication may be used, including finite element models that consider soil-structure interaction.”

I. QUALIFICATIONS OF LOAD RATING PERSONNEL

The *MBE*, Article 1.3, recognizes that the National Bridge Inventory System establishes minimum requirements for bridge inspection programs and personnel. *MBE* Article 4.2.2 identifies the qualifications of various personnel who perform bridge inspections.

The *MBE*, Article 6.1.8, outlines the qualifications and responsibilities of persons who are charged with overall responsibility for bridge-capacity evaluation. Such a person must be a licensed professional engineer having the expertise necessary for the project. Some load rating applications may be of sufficient complexity that the effort will require a multi-disciplinary team of engineers who have the specialized knowledge and skills for the job.

The *TxDOT Bridge Inspection Manual*, Chapter 3, discusses the qualifications and responsibilities of the personnel who are involved in bridge inspection activities. Section 1 identifies that the “individual charged with the overall responsibility for load rating bridges must be a licensed professional engineer.”

B. VISUAL INSPECTION OF THE CULVERT

The culvert load rating process is a component of the inspection process and consists of determining the safe load carrying capacity of the culvert structure, determining whether specific legal or overweight vehicles can safely cross the culvert, and determining if the culvert needs to be restricted and what level of posting is required.

Chapter 5 of the TxDOT *Bridge Inspection Manual*, Article 4.3.5.9 and Article 4.8.8 of the *MBE*, and Section 9.0 of the FHWA *Culvert Inspection Manual* (FHWA 1986) provide specific guidance for performing condition evaluations of cast-in-place concrete box culverts. The typical types of distress to check for include vertical and horizontal misalignment of the culvert barrel, joint defects, cracks and spalls, concrete durability, and footing instability.

Article 6.1.2 of the *MBE* specifically addresses the relationship between field inspection and the load rating and notes that “the condition and extent of deterioration of structural components of the bridge [culvert] should be considered in the computation of... capacity when force or moment is chosen for use in the basic rating equation.” Any discrepancies from plan, or excessive distress such as thin sections, spalling, cracking, deflection, exposed reinforcing steel, and other items which may affect structural capacity, should be noted and considered when establishing actual section capacities.

C. THE CULVERT LOAD-RATING PROCESS

This section presents the process, or *procedure* currently used to load rate bridge-class culverts in Texas – all of which are cast-in-place, reinforced concrete, box culvert structures. The practical observations, knowledge, insights, and lessons learned which formed the basis for this procedure were mostly obtained from a series of culvert load rating research studies TxDOT sponsored over the past ten years and which involved performing thousands of culvert load ratings.

Here it is important to differentiate between the culvert load rating procedure (the subject of this chapter of the *Culvert Rating Guide*) and analytical load rating models (e.g., Level 1, Level 3) which are used to calculate load demands, compute section capacities, and solve the rating factor equation. The load rating procedure provides the big picture of the culvert load rating problem and is presented from the *system-level* perspective, that is, not the rating of one culvert, or ten, but an entire system of such structures.

Figure 10 presents the procedure used to load rate TxDOT bridge-class culverts. A “road map” of the culvert rating process helps avoid confusion, so by way of overview, the procedure consists of seven *tasks*.

Task 1. Document Capture & Classification (by *culvert*).

Task 2. Structure History & Segment Interpretation (by *culvert*).

Task 3. Parameter Interpretation & Data Capture (by *segment*).

Task 4. Design Selection (by *segment*).

Task 5. Level 1 (simple/structural frame) Load Rating Calculation (by *segment*).

Task 6. Level 3 (refined/production-simplified) Load Rating Calculations (by *segment*).

Task 7. Reporting (by *culvert*).

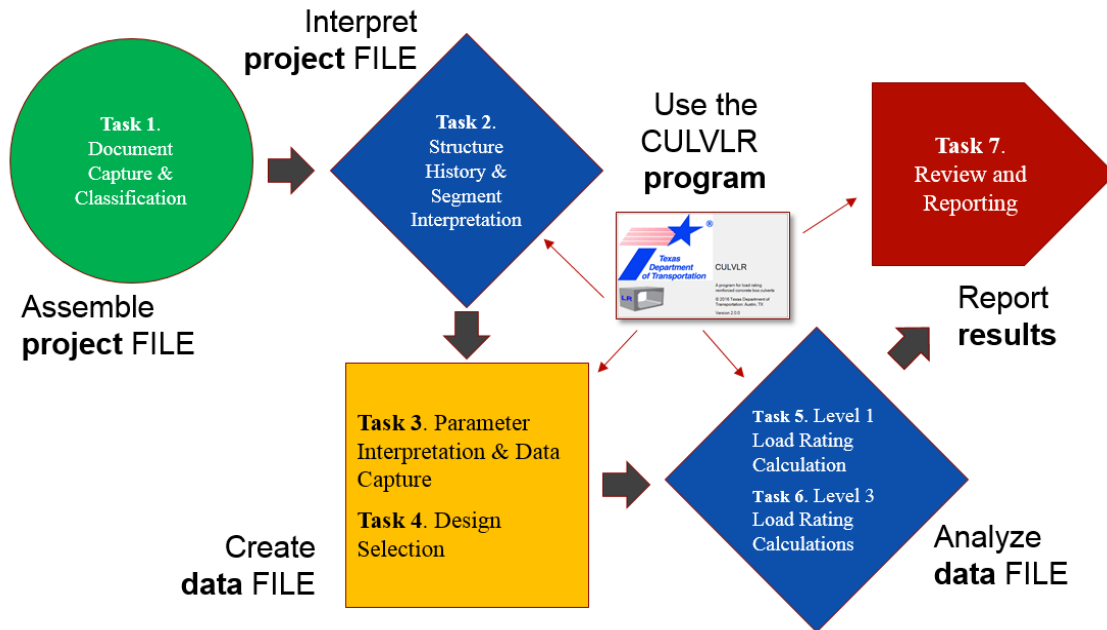

FIG 10. TxDOT Culvert Load Rating Procedure.

These seven tasks comprise the engineer's effort associated with managing a culvert project file relative to load rating. The first step is to assemble the project file, which is Task 1. Because culverts are identified as structures in the National Bridge Inventory, the culvert file is compiled at the structure level.

Task 1. Document Capture & Classification (by culvert).

The place to start is with the culvert document file. TxDOT typically provides digital documents, sometimes from their bridge database and sometimes from their construction drawing archive. If the document file is incomplete, the load rater should always ask for what is missing. In any event, the load rater should open, review, and classify all available documents.

The next step is to interpret the project file, which is Task 2 of the process, also performed at the culvert structure level.

Task 2. Structure History & Segment Interpretation (by culvert).

Available documents should provide a cogent account of the structure history, in particular, the construction date and nature of all culvert segments. The procedure includes a highly-detailed segment classification and identification system. Usually the structure history is clear and segment identification is non-controversial. Sometimes key data are missing or conflicting. Either way, the load rater must make the best interpretation possible. This is a key decision, so the interpretation is documented by means of a 5-point quality rating.

Next the load rating engineer must create a data file for culvert load rating, which involves both Task 3 and Task 4 of the process. The individual design segments which comprise the culvert will have been identified at this point, and data files must be created for all culvert segments.

Task 3. Parameter Interpretation & Data Capture (by segment).

This step is where the load rater obtains and identifies all culvert parameters (except design details) necessary to load-rate a culvert segment. Often data are missing. Frequently data exist in multiple files and are not fully consistent. The load rater must do the work necessary to achieve a complete and un-conflicted dataset. This is the second key decision in the load rating process, so the load rater also documents this interpretation by means of a 5-point quality rating.

Task 4. Design Selection (by segment).

As has been noted, TxDOT uses engineered design standards for their culvert designs. For efficiency, consistency and quality reasons, TxDOT's complete set of older design standard sheets have been digitized and placed in a digital design collective. Further, every design has been catalogued in such a way that the design can be associated with basic parameters such as design year, number of spans, span length, box height, etc. as identified in the previous task. If the culvert documents contain the actual design, the load rater will select it (from the collective, as it is already digitized there). If the culvert documents do not specify the design, the load rater may use known information about the culvert segment, *i.e.*, its unique set of parameters, to identify plausible designs that "match." This represents the third key decision in the load rating process, and the load rater documents this interpretation by means of a 5-point quality rating.

The data files having been identified, it is possible to analyze the data files for culvert load rating purposes, which consists of Task 5 and Task 6 of the process. Again this is done for each culvert segment.

Task 5. Level 1 (simple/structural frame) Load Rating Calculation (by segment).

The load rating engineer is ready to load-rate the culvert segment, and it is common to load-rate each culvert segment multiple times. The first level of load-rating (Level 1) relies on a simple structural frame model, and TxDOT has coded software to fully automate this rating process. The load rating may be iterated over a full range of cover soil depth in order to identify the critical cover soil depth for the structure, *i.e.*, the thickness of cover soil within the range of actual cover soil depths that yields the lowest rating factor. This is defined as the controlling cover soil depth and this parameter is used to define subsequent load rating analyses.

Task 6. Level 3 (refined/production-simplified) Load Rating Calculations (by segment).

This second, more refined load rating analysis (Level 3) is usually the version of the load rating that goes in the culvert file for record purposes. Here, the load rater uses the production-simplified, 2D, finite element model that accounts for soil-structure interaction. The current model accounts for different types of soil, pavement, and a host of other variables.

The final step is to report the culvert load rating results. Here it is appropriate to note that TxDOT's culvert load rating software program, CULVLR 2.0, may be used for much of this work, from Task 2 (interpreting the file) through Task 7 (reporting the results).

Task 7. Reporting (by culvert).

TxDOT's culvert rating program, CULVLR 2.0, offers various reporting options. The load rating engineer typically will include a summary page, culvert segment sketch, individual rating summaries (direct stiffness model) for all segments, individual rating summaries (finite element model) for all segments, and a project documentation sheet that identifies all files from which data were obtained to support the rating factor calculations. Detailed reports of program input, capacity, demand, and rating factor calculations can be provided if necessary.

D. SELECTION OF THE PROPER LEVEL OF ANALYSIS

The load rating process presented in this *Guide* recognizes a hierarchy of analysis for the demand calculations. The level of analysis chosen is a trade-off between sophistication of analysis and required work effort. The simpler method (Level 1) is frequently selected as a first choice due to the need to analyze many structures with limited resources. When the Level 1 analysis yields satisfactory results, there may be no need to use a more sophisticated model. Satisfactory results would be the establishment of safe load carrying capacity that does not require posting the structure and does not unduly restrict the flow of permitted overweight trucks.

A more sophisticated analysis (e.g., Level 3) is justified to avoid posting the structure or to ease restrictions on the flow of permitted overweight trucks. Of course, the goal of the load rating process is not to force any particular culvert to "rate", but instead to establish a valid load rating for the culvert. The fact that more sophisticated models tend to more accurately model the moment, shear and thrust demands, and thus yield higher rating factors, cannot be pressed indefinitely. Load rating should reliably depict actual or expected culvert performance. Culverts which cannot safely support design traffic loads should be rated accordingly, and culverts which are not performing in a manner that indicates they can carry design traffic loads should not be rated as if they can.

E. REVIEWING AND CHECKING CALCULATIONS

The load rating process recognizes a balance between safety and economics. Standard quality control procedures require that both in-house and consultants' load rating results should be checked for accuracy.

Consistent with *MBE* Article 6.1.8 and Chapter 3 of TxDOT's *Bridge Inspection Manual*, load rating analyses must be performed under the direct supervision of a Licensed Professional Engineer who is knowledgeable about the load rating process. Whenever possible, the load rater should perform long hand checks of a portion of the computer analysis to satisfy the load rater that the computer output is valid. It is of utmost importance that the load rater understands when computer results are reasonable. Blind faith in any computer program should be avoided.

An independent check of the analysis should be performed. The checker should verify all input data for computer programs, verify that the summary of load capacity information accurately reflects the analysis, and be satisfied with the accuracy and suitability of the computer output.

4. CULVERT DOCUMENT CAPTURE AND CLASSIFICATION

A. THE “IDEAL” CULVERT DOCUMENT FILE

The data required to perform production-simplified load rating calculations using the LFR approach for a reinforced concrete box culvert are summarized as follows. Parameters are identified specific to each segment in the culvert structure:

- Structure history – segment identification, build year, overall layout
- Culvert geometry parameters – span number, span length, box height, haunches, skew
- Culvert design parameters – design sheet/design standard name, design year, steel grade, concrete class, condition rating/localized defects
- Load parameters – highway load, lane load, live load distribution out-of-plane
- Environmental parameters – cover soil depth, soil type, soil stiffness, pavement type, pavement layer thicknesses, and pavement layer stiffnesses

Ideally, the load rating engineer would be provided (or obtain) a complete, accurate, and non-conflicting set of *as-built* data for each and every parameter, for each culvert segment. This definitive case rarely exists in practice, but it is important to mark where one starts making interpretations and assumptions. In load rating, this starts when the load rating engineer chooses to interpret parameters from available data, namely, the culvert document file. This practice is reasonable and widely-accepted (*MBE* Article 6A.5.12.1), and while most data obtained from documents are usually reliable, the information in the document files are sometimes a surrogate for actual, as-built, measured parameters and properties (*MBE* Article 6A.5.12.9).

In contrast to the ideal case, in practice a “reasonably-complete” document file will consist of an Inventory Record (the culvert is identified in the NBI database), one or more structural Inspection Reports (which usually include some photos and coded assessments of the various structure components), and the original construction drawings or at least the design standard or design standard name for the culvert. Many (but not all) load rating parameters can be obtained from these culvert documents or they are specified by policy.

However, even when the culvert documents are reasonably-complete, it is exceedingly rare that the file contains *any* geotechnical borings, soil test data, or pavement data. Further, information is not typically collected or provided at the segment level, even though load rating calculations (*i.e.*, a full set of parameters) must be performed for each culvert segment. Only occasionally does the file include multiple sets of construction drawings which depict most of the major reconstruction events over the culvert service life.

The construction drawings and in particular the culvert design sheet deserves specific mention since the drawings/design are the most significant source of data needed for specification of the culvert model. Review of a statistically-representative sample (1,000 culverts) of TxDOT’s population of pre-1980, on-system bridge-class culverts showed that the design sheet was provided for 38% of culvert segments, and the design was specified by name for an additional 11% of segments. This means that for

about half of the culvert segments in the TxDOT inventory, designs were not available in the culvert document file.

B. COMPILING A REASONABLY-COMPLETE CULVERT DOCUMENT FILE

The reality of culvert load rating is that the ideal case of complete, culvert-specific, as-built data will likely never happen. The typical case of a complete document file – which still does not fully identify all parameters necessary for a culvert load rating model – will only occur part of the time. Faced with the situation of incomplete or conflicting data, responsible load rating engineers will either obtain more data or they will start making documented interpretations and assumptions. For this reason, the challenge to individual load-raters is to consistently, uniformly and systematically accomplish reliable data which will lead to accurate and precise culvert rating results.

Investigative effort helps. For example, it is common for load rating engineers to work with the *digital* document file as this is often deemed “all that is available.” But perhaps old, tattered, hard-copy original construction documents might exist in archive storage somewhere in the midst of thousands of other files plus dust, spiders, and back-breaking labor (Figure 11). The effort and expense in searching for documents must be considered and weighed against the benefit.



FIG 11. A Complete Set of Original Construction Documents May Be Difficult to Locate and Obtain

A good way to think about culvert load rating is that an accurate and precise load rating factor sources to and requires both valid *data* and a valid load rating *model*. While the model is of course important, obtaining the data is where the bulk of work is performed in culvert load rating. This is where hours are spent, issues are identified, and questions are asked. This is where key assumptions and interpretations are made. And this is also the likely source of inconsistency and error. When viewed from the *system* level, unquestionably the challenges are greater for the rating *process* than for the rating *model*.

An apt analogy is the painting of an old house. If the project takes a week, the paint crew will spend three days prepping, one day painting, and one day cleaning up. This is not to say that the quality of the paint will not affect the final outcome. But the prep has to be right, and in fact, the finish coat can rarely overcome sloppy prep work. As in paint contracting, so in load rating, the prep (process) must be solid and thorough. Further, only from the perspective of good prep can the quality of different finishes be fully appreciated.

The lesson learned is that approved load rating begins with a sound process that enables the load rating engineer to systematically achieve a quality set of reliable load rating parameters, *by culvert segment*. Only then can the important – even *critical* – questions of rating model selection, calibration and application be approached with insight and confidence. If the rating factors obtained from such a process are still questionable – *i.e.*, they do not match observed structure performance, a sound place exists from which to diagnose potential causes of the disconnect. At a minimum, the load rater will know “the problem’s not with the data.”

C. READILY AVAILABLE DOCUMENTATION

Much culvert load rating work is accomplished using data obtained from reviewing *available* culvert documentation in *digital* format. It is rare – at least for initial load rating efforts – to travel into the field to measure or obtain culvert-specific data (Figure 12). Further, it may not be practicable to obtain or review any printed (hard copy) culvert documents. While the load rating engineer should request all documents of every type for the culvert being rated, the load rating effort may be limited to the body of digital documents available from the culvert document file, some from the Bridge Division database, and some from TxDOT’s construction drawing archive.



FIG 12. For Initial Load Rating Efforts, it is Rare to Obtain Project-Specific Data from the Field

The process of document capture involves searching for documents directly associated with the structure, and also by cross-referencing control and section numbers to identify additional documents associated with the structure which were filed under other construction jobs. Documents available from these sources often include but are not limited to:

- PonTex database (NBIS data)
- Bridge Inventory Record (Figure 13)
- Structural Inspection Report(s)
- Inspection Photo(s)
- Construction Documents (partial or complete set)
- Culvert Design Standard(s)
- Load Rating Statement(s)
- Sketch(es)

Bridge Inventory Record

District: 23 County: 068 Cont-Sec: 0007-04 Structure: 159 Route: IH 20 ML & FR
 Feature Crossed: Draw Inspector's Signature: [Signature], P.E. Date: 3/30/2012
 Company Name: [Company Name] (F-)
 Location: 0.50 Mi NE of FM 570 Maintenance Section: 04
 Latitude: N 32° 24' 16.23" Longitude: W 98° 46' 58.63" Milepoint: 20.221
 General Description: 2 barrel 8' x 8' concrete box culvert. Non-standard guardfence at the outlet. No guardfence at the inlet. Bridge is on a high-speed, paved road with very high ADT (~ 15,000 vpd).

Bridge Length: 24 ft. Deck Width: 281 ft. Lanes On: 8 Lanes Under: 0
 Skew Angle: 45 Deg. Lf. Fwd. Rt. Fwd. Bridge Rail: N/A MBGF (SOUTH ROAD ONLY)
 Clear Width Between: 134 ft. Curbs, Rails, Pvmt Edges Approach Rdway Wid: 134* ft.
 Deck Type: Concrete

Surfacing: Asphaltic pavement on 2' to 4' of fill Vertical Over-Clearance: ft. Unimpaired

Stringers: Spans: N/A
 Type: Size: Number:
 Spacing: Controlling Span Length (C-C bearings): ft.

Stringers: Spans:
 Type: Size: Number:
 Spacing: Controlling Span Length (C-C bearings): ft.

FIG 13. The Document File for all Bridge-Class Culverts Typically Contains a *Bridge Inventory Record*

In addition to documents from the file, other culvert documents/ data needed for load rating may be obtained from both TxDOT and non-TxDOT sources. These include geotechnical data, pavement data, culvert structure properties, and culvert condition rating data.

D. GEOTECHNICAL DOCUMENTATION

Geotechnical documents are typically not available for TxDOT culvert structures. Occasionally when the project file includes a full set of construction drawings, in such cases the plan/profile sheets might show a geotechnical boring in the vicinity of a structure, but this is quite rare. Even rarer is a post-construction geotechnical study that specifically identifies and characterizes the subsurface materials

and conditions above the culvert top slab, adjacent to the culvert exterior walls, and below the bottom slab of the as-built culvert structure. To address this void in the documentation, this *Guide* has adopted an “approximate” procedure for characterizing the subsurface materials surrounding and supporting in-service culverts, consistent with the production-simplified load rating approach. This data applies to the Level 3 (soil-structure interaction) modeling approach.

This procedure is based on two underlying assumptions: (1) the excavations associated with original culvert construction were typically backfilled with *native soil* obtained from the site where the culvert was built, and (2) such native soils therefore uniformly surround the base, sides and surface of the culvert structure. In effect, the “soil” surrounding the culvert is simplified as a homogenous, isotropic geomaterial having properties typical for the native soils at the culvert construction site.

The following steps operationalize this procedure:

- 1) The culvert location must be carefully identified in terms of longitude and latitude, as per available NBIS data.
- 2) The culvert is geo-located relative to the soil association maps in the USDA/NRCS Web Soil Survey (Soil Survey Staff 2016) to identify the soil map unit(s) for the area of interest.
- 3) With the predominant soil map unit(s) identified, the Web Soil Survey database is used to identify engineering properties of the typical soil profile(s) by layer, in particular, the soil classification (Unified Soil Classification group symbol).
- 4) The “average” soil classification for the profile(s) is established using a simple calculation, and normally the outcome is a straightforward interpretation. A set of pre-determined decision rules may be used to resolve non-typical cases.
- 5) Finally, the average soil classification representative of the culvert site is correlated to nominal dead load and live load soil stiffness values as described in Chapter 6 of this *Guide*.

This procedure is arguably simple. In addition to concerns imposed by its basic underlying assumptions, this approach is also subject to limitations associated with the reliability of the Web Soil Survey data. Ideally, project-specific geotechnical data would be available for every culvert site, and reliable material properties specific to culvert load rating would also be available. But when site-specific data are not available or are prohibitively expensive to obtain, the procedure described herein provides a rational approach to identify approximate soil properties that facilitate production-simplified soil-structure demand modeling.

E. PAVEMENT DOCUMENTATION

Detailed, project-specific pavement data are typically not available for TxDOT culvert structures. However, unlike the case for geotechnical information, the project file always includes a Bridge Inventory Record and site photos, and usually these documents provide a statement or some indication about the pavement type. But seldom if ever does the culvert project file include records identifying the pavement system, pavement layers, pavement thickness, material properties, etc.

To address the void, this *Guide* has adopted a rational “approximate” procedure for more definitively characterizing the pavement structure overlying the culvert, consistent with the production-

simplified load rating approach. This data applies to the Level 3 (soil-structure interaction) modeling approach. The process includes the following steps.

- 1) The location of each culvert is carefully identified in terms of its Texas reference marker and displacement data, as per available TxDOT/NBIS records.
- 2) TxDOT pavement engineers use the culvert location to cross-link to TxDOT's Pavement Management Information System (PMIS) database (TxDOT 2014).
- 3) The PMIS database (Figure 14) characterizes TxDOT's entire on-system roadway network in terms of 0.5-mile data collection sections. Thus, the pavement type overlying each culvert structure can be identified to this degree of resolution.
- 4) The PMIS database does not provide pavement core records, layer thickness, or material property data. For the purposes of this load rating study, the best PMIS data available are the "detailed pavement type" of which there are ten.

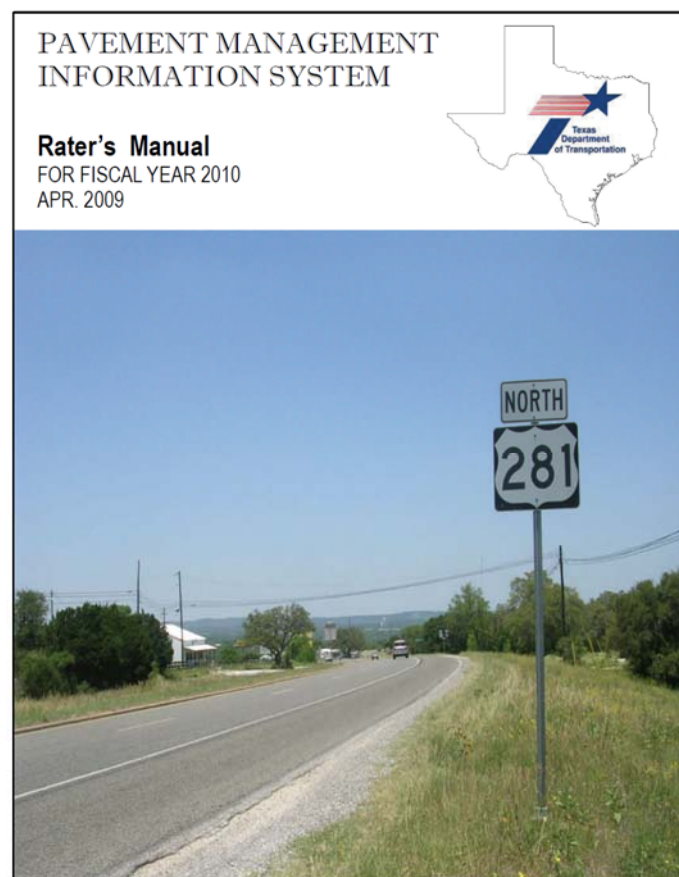

FIG 14. TxDOT's Pavement Management Information System contains the "Pavement Type" for Roads Overlying Culvert Structures

- 5) The detailed pavement type is established from the PMIS data, and normally the outcome is a straightforward interpretation. Results are checked against the Bridge Inventory Record and photos. A set of pre-determined decision rules is used to resolve non-typical cases.
- 6) The nominal pavement type can be associated with equivalent pavement structure properties necessary for culvert load rating purposes. See Chapter 6 of this *Guide*.

As with the geotechnical data, questions can be voiced about the reliability of pavement data obtained using approximate methods. But when project-specific data are not available or are prohibitively expensive to obtain, the procedure described herein provides a rational approach to facilitate the inclusion of the beneficial aspects of the pavement structure in the production-simplified soil-structure demand model.

F. CULVERT STRUCTURAL PROPERTIES

Detailed, project-specific, as-built or contemporaneous structural properties are rarely available for TxDOT culvert structures. Therefore, nominal concrete compressive strengths, reinforcing steel yield strengths, and related structural information must be obtained from construction documents in the project file.

Rather than accept material property information that might appear in the design standards (where available), this *Guide* has adopted the practice that material properties are correlated by build year for each segment of the culvert structure. The structural properties are then obtained from the appropriate edition of TxDOT's historical archive of *Standard Construction Specifications*.

G. STRUCTURE CONDITION RATING DATA

The quadrennial NBIS Bridge Inspection Records contain numerical ratings that may be used to categorize the condition (performance) for each component of a culvert structure. Report item 62 provides fields where structural engineers rate the "top slabs", "bottom slabs or footings", "abutments & intermediate supports", "headwalls & wingwalls", and "other." The lowest value from these individual ratings is the overall "component" rating for the structure.

It is often desirable to capture these structural condition ratings as an independent measure of the performance of the structure in order to facilitate comparison with calculated load ratings. Further, these condition ratings may help alert the load rating engineer to possible damage to one or more elements of the culvert. For these data, the load rating engineer must rely on the condition ratings identified in the most recent Bridge Inspection Record available in the culvert project file.

H. THE "PRODUCTION-SIMPLIFIED" DATASET

Collectively, the document capture and review process presented herein should result in a body of information from which nominal data for most parameters necessary for culvert load rating can be identified or at least approximated.

This is not to say that more definitive, project-specific, as-built data would not refine or "tighten up" the dataset, and the load rating engineer should generally use the best data available. The decision to

invest in the effort and expense to obtain project-specific information must be addressed within the context of project-specific considerations.

For cases where nominal properties must be assigned and project-specific information is not available, the systematic procedures for document collection and review described in this *Guide* will help ensure a defined and well-specified dataset, consistent with production-simplified load rating work.

I. CULVLR 2.0 SOFTWARE – CULVERT DOCUMENT CAPTURE

Culvert document capture and classification, which is the first step of the culvert load rating process, is essentially about getting all available culvert information compiled and organized before commencing the more technical aspects of load rating. This work must be performed prior to any of the load rating tasks which CULVLR 2.0 is intended to support. Therefore, CULVLR 2.0 is not used for this step.

J. EXAMPLE PROBLEM – CULVERT DOCUMENT CAPTURE

Appendix A of this *Guide* presents a worked example for culvert document capture and classification.

5. STRUCTURE HISTORY AND SEGMENT INTERPRETATION

A. THE NEED FOR SEGMENT IDENTIFICATION

During their service lives, culverts sometimes require upgrading to improve traffic capacity, hydraulic capacity, or both. Thus it is not unusual for culvert structures to be widened (normal to the centerline) or lengthened (spans added) years or decades after the original culvert is built. This is true in Texas where detailed culvert documentation shows that 49 percent of Texas culverts have multiple design segments, and it is also true nationally where NBIS data suggest that 10 to 15 percent of culverts have experienced a significant reconstruction event. These major culvert modifications are usually done under designs and specifications which differ from the original structure. This means that an approved load rating process must identify, define, and account for all unique segments of the culvert structure, and the principle of superposition requires that load rating calculations be performed for each and every culvert segment. Thus, it is necessary for available documents to provide a cogent account of the structure history, in particular, the construction date and nature of all culvert segments.

B. THE CULVERT SEGMENT CONCEPT

One of the myths of culvert load rating is that the process is about load-rating culverts. But this is misleading, because the load-rating engineer actually analyzes and load-rates individual design *segments* of culverts, and it is from the collective segment ratings that the overall load rating for the culvert structure is determined.

Figure 15 illustrates the distinction. The top image (Figure 15a) is a culvert structure which was built entirely at one time using a single design, and not subsequently modified. This culvert structure is comprised of one culvert segment, and about half of TxDOT's inventory of pre-1980, on-system, bridge-class culverts fall in this category. The other half of TxDOT's culverts contain *more than one* segment, illustrated by the structure in Figure 15b which is comprised of three segments. Each culvert segment has a different design, so each segment must be analyzed and load-rated independently. The segment with the lowest rating controls and sets the load rating for the culvert structure.

(a)



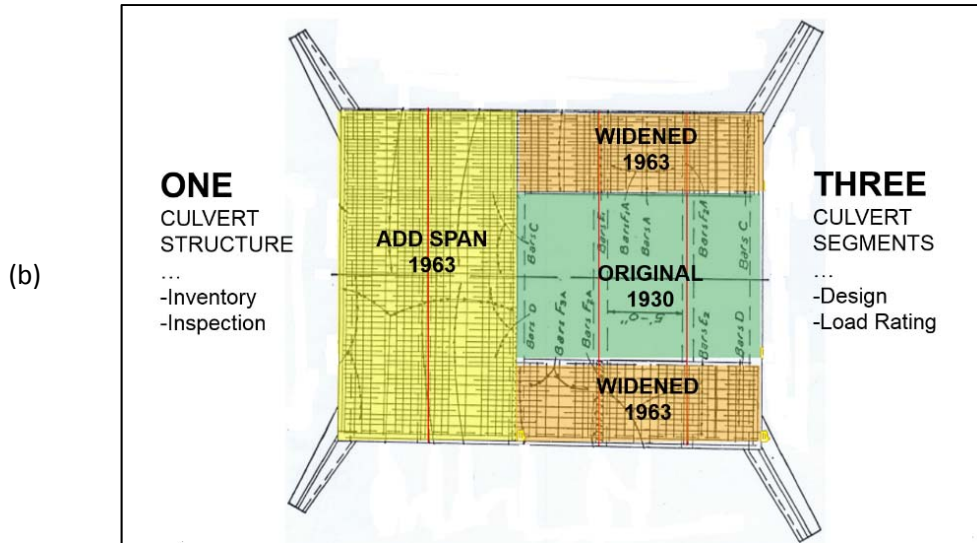

FIG 15. The concept of culvert segments: (a) one-segment culvert and (b) three-segment culvert.

When data for culvert segments are not identified or captured, this limits the fidelity of the dataset. The source of this oversight is partially based in the vernacular of the NBI. In NBI terms, the inventory is for bridge-class culvert *structures*, and inspections are made for bridge-class culvert *structures*. Direct provision is not made for capturing data on individual segments of a structure other than Item 75 which records the type of work proposed to improve a structure, or Item 106, which records the year of most recent reconstruction of the structure (FHWA 1995). This is in contrast to data for bridges proper where separate fields exist to capture information about components such as the bridge deck, etc. The cost of not identifying segments is the missed opportunity to sensitize bridge inspection personnel to potential areas of different structure performance.

C. CULVERT SEGMENTS IN TxDOT’S PRE-1980 CULVERT STRUCTURES

Review of documents for a statistically-representative sample of 1,000 TxDOT culverts identified the number of segments for these structures (Lawson et al. 2016). Figure 16 presents the findings.

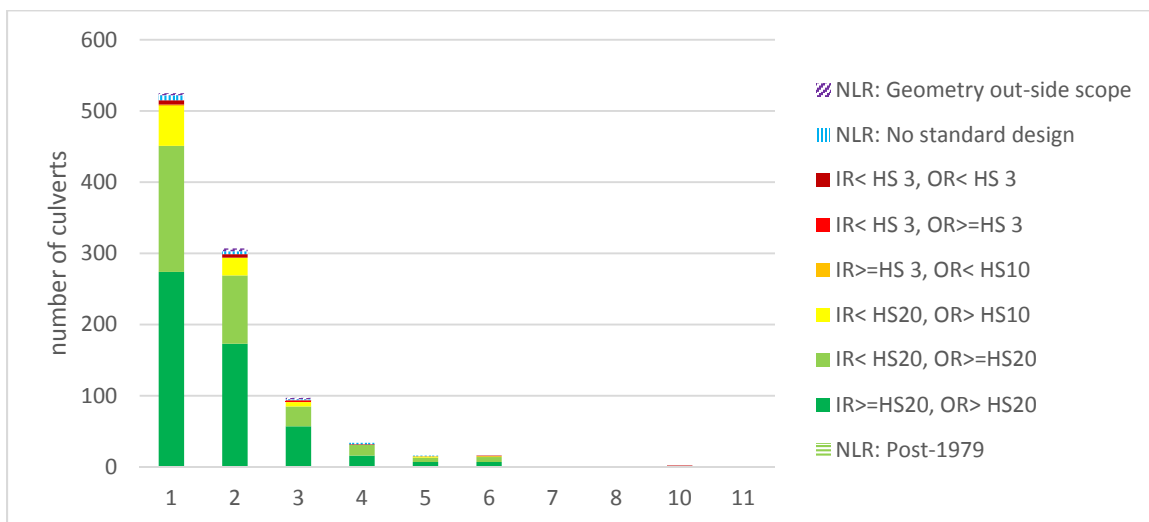

FIG 16. Culvert Load Rating Performance by Number of Segments

The median number of segments for TxDOT culvert structures is one (52.5% ±2.9%), and the 90th percentile is three segments (92.9% ±1.5%), with the total number of segments per culvert ranging from 1 to 11. Overall, the Texas inventory comprises an average of about 1.8 segments per culvert, all of which have to be load-rated.

D. SEGMENT IDENTIFICATION PROCESS

Segment identification and structure history interpretation begins with a highly-detailed segment classification system as shown in Figure 17. The segment key shows five identifying features. First is the segment number, which is assigned chronologically, with the oldest segment being 1, the next segment being 2, etc. In this way, the load rater can quickly identify how many segments exist for a culvert structure.

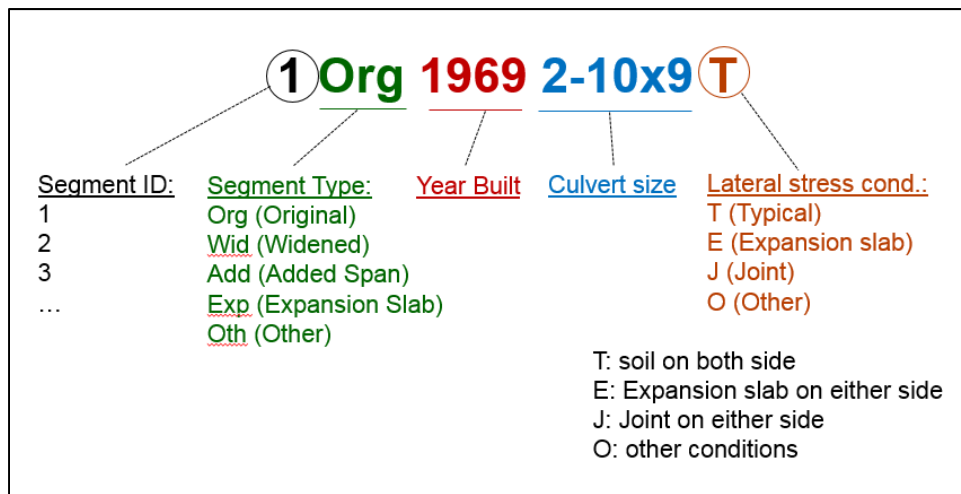

FIG 17. Syntax and Interpretive Key for Segment Identification

The next identifier is segment type, which defines five specific cases typical for TxDOT’s population of cast-in-place, reinforced concrete boxes. Every culvert will have an original segment which sometimes is the *only* segment. Some culverts were initially constructed with multiple segments using multiple designs, so it is also possible for a culvert to contain multiple original segments. Reconstruction events after original construction typically involve culvert widening, and in some cases lengthening, so these are also identified. Another type of segment is the expansion slab. This segment type is not a reinforced concrete box but rather a heavy slab supported by bracket bearing surfaces and used to join adjacent culvert segments. “Other” is used to describe all other non-box culvert segment types that may be part of the structure including pipes, three-sided shapes, etc. While these other types are rare in TxDOT’s bridge-class culvert inventory, they do exist.

The ‘year built’ refers to the year the culvert segment was constructed. NBIS data identify the ‘year built’ for only the original culvert structure, but it should be apparent that segments can and often are constructed in different years, and this field captures that information.

The ‘culvert size’ is a short-hand way to define the reinforced concrete box geometry for the segment. The typical syntax is: number of spans, span length, and box height. Thus the segment identified in Figure 15a is comprised of two identical spans (also termed boxes or barrels) with dimensions of 10ft wide by 10ft high.

The final identifier refers to the lateral stress condition for the exterior culvert walls. Typically a reinforced concrete box culvert is buried with soil not only above and below the structure, but also with soil bearing against the outside of both exterior culvert walls. That is the *typical* case, and the analytical models used to calculate load demands on a box culvert assume this typical case for load rating (*i.e.*, soil all around). But when the culvert consists of multiple segments, the typical case does not always exist. For example, sometimes the exterior wall of a culvert segment will *not* bear against soil but instead will support an expansion slab. Or, when two segments are constructed side by side (as when culverts are lengthened), only a joint exists between the segments. The culvert modeling software does not identify or analyze these differential lateral stress conditions, but it is appropriate to note the deviation.

Having established the segment identification key, interpretation of the structure history and segment identification becomes an *inductive* process of characterizing the culvert based upon review of all available data. The following steps apply:

- 1) Review captured documents.
- 2) Create a rational interpretation of segments.
- 3) Draw sketch of interpreted segments.
- 4) Name each segment.
- 5) Annotate source documents.
- 6) Cycle through this process and adjust interpretation to achieve best fit.

The typical case is that the assembled documents from the culvert file “tell” a straightforward, non-conflicted story, and the structure history and segment identification are clearly apparent. However, sometimes – especially for older and complex structures – multiple alternative interpretations are possible. Either way, established practice in this *Guide* is to identify the best possible interpretation using the available data, to document that decision, and to move on to load rating from there. Concurrent with this goal, resolution of missing or conflicting data sometimes results in uncertainty associated with the interpretation. This is a key decision, so it is appropriate to document the interpretation by means of a 5-point quality rating.

E. QUALITY SCORE FOR STRUCTURE HISTORY AND SEGMENT INTERPRETATION

Table 3 presents the quality score rubric for interpretation of the structure history and segment identification. Usually the structure history for a culvert is clear and segment identification is non-controversial as has been noted. But sometimes key documents for a culvert are missing or data from multiple sources are in conflict.

The first column (Column a) of Table 3 identifies the numerical quality score. As would be expected, high scores (4 to 5) represent high quality culvert data characterized by high reliability and few to no conflicts in the document record. The interpretation of such data is essentially clear and unambiguous. On the other end of the spectrum, low quality scores (1 to 2) represent culvert data characterized by questionable reliability and a document record fraught with holes or conflicts. Interpretation of such data is questionable.

Because the interpretation of structure history and segment identification is established inductively relative to the available culvert documents, the assessment primarily focuses around the existence (or absence) of conflicts, irregularities, and missing data in the culvert file. These are captured by a “concern score” and this appears in Column (b) of Table 3. Conflicts in the document record are assessed as either “minor” or “major” concerns, with minor concerns assigned a score of 1 and major concerns assigned a score of 3, and the sum of the concern scores associated with interpretation quality.

Table 3. Quality Score Rubric for Structure History and Segment Identification

Quality Score	Concern Score	Descriptive Assessment
(a)	(b)	(c)
5	0	Very high reliability: clear and unambiguous data
4	1 - 2	High reliability: reasonably complete and unconflicted data
3	3 - 4	Average reliability: minor/ limited conflicts or missing data
2	5 - 6	Low reliability: significant missing or conflicted data
1	≥ 7	Very low reliability: incomplete or heavily conflicted data

Minor concerns, for example, include conflicts in the file without a clear resolution but which would have little effect on the segment interpretation or load rating, or questionable duplications such as a drawing which was likely misfiled or added in error. By contrast, major concerns include but are not limited to culvert records with a sizeable gap in the documentation where the nature of any segment(s) during that gap is not clear, or cases where documents do not indicate widening or added spans but the inspection photos do indicate such modification, or cases where odd features exist in the culvert structure but are not explained or were undocumented.

Three peculiar cases are deemed neither minor nor major. These cases include (1) scenarios where the only sources of information are primary documents – namely, the inventory record, inspection photos and the PonTex database, (2) scenarios where the data conflict but the conflict is clearly resolved based on indisputable evidence in source documents, and (3) scenarios where information about a structure is ambiguous but this has no effect on load rating. These peculiar cases are regarded as non-consequential to load rating and result in no discount to the quality score for interpretation of structure history and segment identification.

This basic interpretive approach is rational in that *more* concerns and *more severe* concerns about the culvert documentation rightly imply questions about the quality of the assessment, and the relative quality score captures this effect. Figure 18 summarizes the quality score for interpretation of structure history and segment identification for 1,000 TxDOT culverts.

This figure reveals generally high confidence in the interpretation of structure history and segment identification, with 95.6 percent of the 1,000 culverts having a score of 4 or better. Only 0.6 percent had quality scores less than or equal to 2.

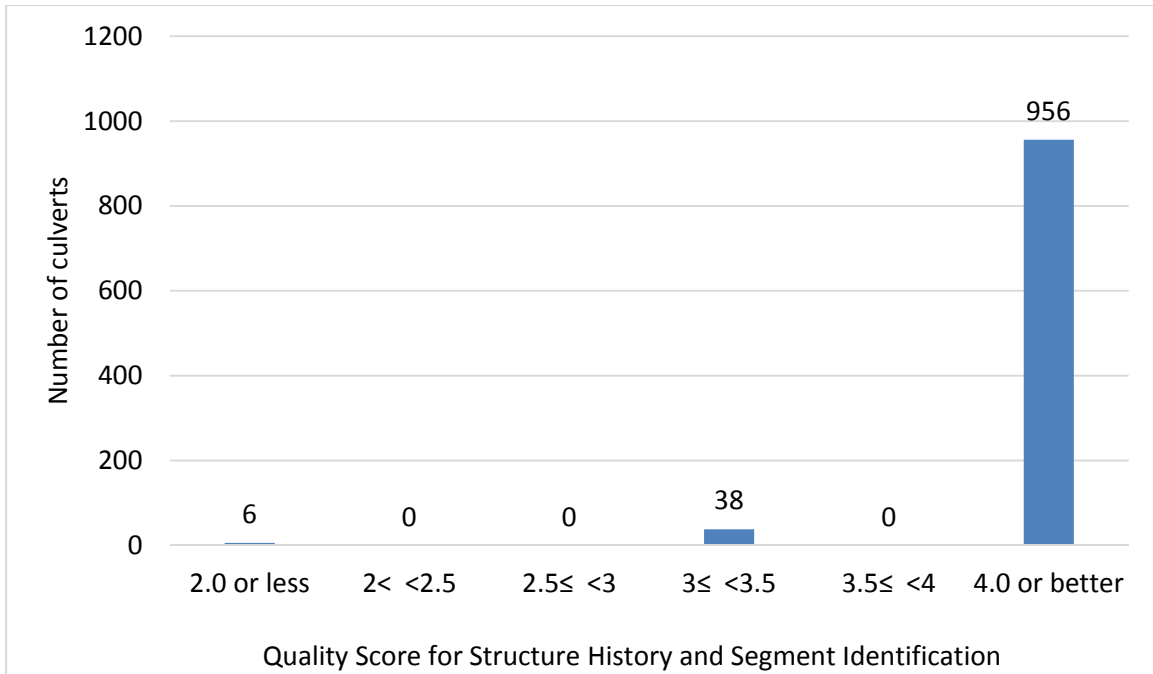

FIG 18. Interpretation Quality Score for Structure History and Segment Identification

As a practical matter, this *Guide* recommends that the load rater always identify the best possible interpretation using the available data, realizing that lower quality data might be of questionable benefit. The quality score documents this, and the decision of whether and how to use such results should be addressed based on case-specific considerations.

F. CULVLR 2.0 SOFTWARE – STRUCTURE HISTORY AND SEGMENT INTERPRETATION

Structure history and segment interpretation, which is the second task of the culvert load rating process, is where the load rating engineer identifies his/her best interpretation about the number and nature of segments for a given culvert structure. This sets the stage for the load rater to proceed with the more technical aspects of load rating, *by culvert segment*. Given the critical importance of identifying culvert segments, data input for CULVLR 2.0 begins with this step. Information is largely descriptive, allowing the load rater to document with clarity all data for the particular culvert segment being load-rated.

G. EXAMPLE PROBLEM – STRUCTURE HISTORY AND SEGMENT INTERPRETATION

Appendix B of this *Guide* presents a worked example for structure history and segment interpretation. This example includes a detailed guidance document for establishing the quality of segment interpretation.

6. PARAMETER INTERPRETATION AND DATA CAPTURE

A. PARAMETERS FOR CULVERT LOAD RATING

This load rating task, Task 3, is where the load rating engineer reviews the project file and identifies all parameters (*except* design details – see next chapter) necessary to load-rate a culvert. Solution of the rating factor equation (Equation 1) is based on primary structural analyses associated with the calculation of culvert capacity, dead load demands, and live load demands, and this is done for every critical section in the culvert structure. This means the rating factor solution is obtained for each *segment* of a culvert as interpreted from the culvert document file. In turn, the structural analyses are achieved through production-simplified computational models, and it is these models which dictate the parameters needed to specify each and every segment.

Figure 19 conceptually depicts the classes of data needed for load rating. These include culvert geometry, design information, site information, other information that may be available, and recognition that data are sometimes missing.

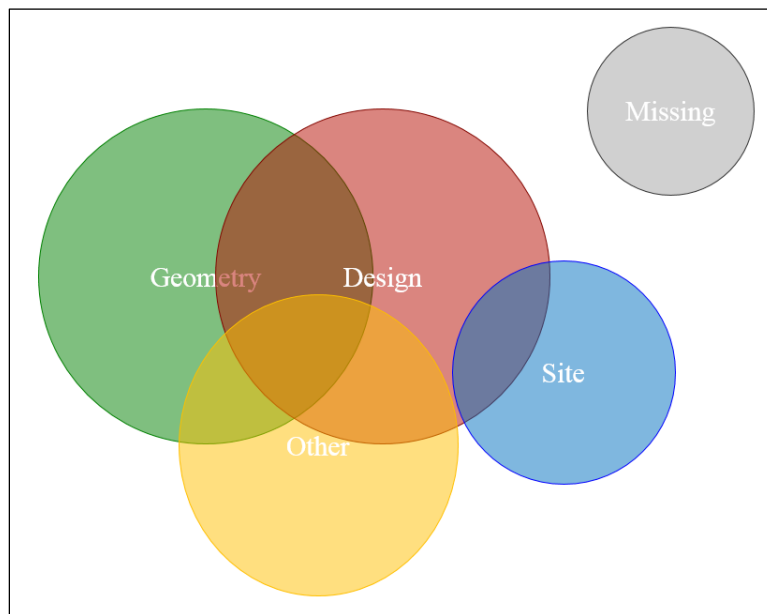

FIG 19. Data Needed to Load Rate a Culvert Segment

As used in this *Guide*, ten parameters are identified to adequately specify a culvert segment. Most of these parameters are specific to the segment and include number of spans, span length, box height, skew, haunches, year built, and the design standard.

- Culvert geometry parameters are the number of spans, span length, box height, skew, and the presence or absence of structural haunches. The significance of these parameters to structural analysis is obvious, and the ideal case is where the project file contains rectified as-built construction drawings explicitly identifying such information. Better yet, sometimes the file contains both as-built construction drawings *and* recent inspection photographs that confirm these parameters.

- The year built is classified with the design parameters and refers to the construction year. The most definitive statement of the build year is when the project file contains rectified as-built construction drawings explicitly identifying the year of construction. The build year is important because it strongly associates with construction material specifications such as steel grade and concrete class, and these important details are often not directly available otherwise.
- The structure design refers to the *actual drawing* (design standard) used to construct the culvert segment. Sometimes the file contains this drawing, and this is in contrast to other cases where the file only references a design (sheet) *name*, this name being a shorthand reference to the design standard. Sometimes the project file contains both the design and appropriate references to it. Either way, owing to the importance of the design relative to load rating, it is always important to look for the most complete and definitive design information available.

In contrast to segment-specific parameters, other parameters necessary for load rating are typically identified at the culvert level (i.e., are common to all segments) and these include cover soil depth range, soil type (stiffness), and pavement type.

- The minimum and maximum cover soil depth, that is, the thickness range of cover soil above the top surface of the top slab of the culvert, is an important parameter. The relationship between cover soil depth and load rating is highly non-linear and highly significant (Lawson *et al.* 2016), and culvert designs are typically classified by this variable, *i.e.*, direct traffic (0 to 2 ft of cover soil), low fill (2 ft to 6 ft of cover soil), or deep fill (greater than 6 ft of cover soil). Cover soil thickness data are sometimes available from the construction drawings or from notes in the inventory record, or sometimes the cover soil depth can be reasonably estimated from inspection photographs.
- Soil data are necessary to model the “soil-structure” interaction aspects of culvert behavior. As noted in Chapter 4 of this *Guide*, project-specific geotechnical information is rarely available for load rating purposes, so the production-simplified approach used in this *Guide* allows for the culvert soil to be approximately identified from Web Soil Survey data.
- Pavement data are important by virtue of the fact that the presence or absence of pavement above the culvert influences the attenuation of live load to the structure. For the production-simplified approach used in this *Guide*, the pavement type is identified in terms of established types of pavement per TxDOT’s Pavement Management Information System.

Other culvert parameters exist of course, such as document dates, number of traffic lanes, etc. – but these ten are the most significant parameters for load rating.

B. OVERVIEW OF THE PARAMETER IDENTIFICATION PROCESS

All available files for a culvert structure are identified by the structure history and segment identification interpretation process (Task 2). From these documents, capture of the required parameters/ data (Task 3) amounts to carefully reviewing each file and accurately documenting the values present from each file. Because multiple data sources exist for the identified rating parameters, this sometimes results in over-specified data or conflicting data. Conversely, a less than complete project file results in unclear data or missing data.

However, load rating necessitates a unique, complete and unconflicted dataset. The parameter interpretation performed in Task 3 must resolve all data issues for the segment. Achieving such data represents a second key decision in the culvert load rating process. Therefore the load rating engineer documents his/her interpretation of the key parameters for each culvert segment by means of a 5-point quality rating.

C. UNITS AND DIMENSIONS

1. UNITS

It is appropriate to comment on units, both for measurement and analysis. Consistent with TxDOT practice, this *Guide* presents U.S. Customary Units throughout. Gross culvert dimensions including the clear span, clear height, and depth of cover soil should be measured in feet. Culvert structural dimensions, wall thicknesses, etc. should be measured in inches. The units of measurement will be the units of analysis.

With respect to material properties, concrete strengths should be presented and analyzed in terms of pounds per square inch (psi). Reinforcing steel strength should be presented and analyzed in terms of kips per square inch (ksi).

With respect to loads, soil unit weight is identified in terms of pounds per cubic foot (pcf) but analyzed in kips per cubic foot (kcf). Vehicle live loads are presented in kips, converted to stress in terms of kips per square foot (ksf), and analyzed in kips per square foot (ksf). Spacing between wheel loads should be presented and analyzed in feet.

Output data from the analytical programs (shear, moment, thrust) are presented in terms of kips and feet. Load ratings which are determined based on the HS-20 standard rating vehicle are expressed in terms of the HS tractor tonnage. Load ratings determined from alternative vehicles are presented in terms of the rating factor (dimensionless).

2. DIMENSIONS

The culvert dimensions must be collected from the construction documents or established based on field measurements. The required dimensional information is summarized in Table 4 and Figure 20. These values define the gross section properties for all levels of analytical modeling.

TABLE 4. Culvert Dimensions Required For Load Rating Calculations

<i>Dimension</i>	<i>Abbreviation</i>	<i>Units</i>
<i>Number of spans</i>	<i>N</i>	-
<i>Cover soil depth</i>	<i>D</i>	ft
<i>Clear span</i>	<i>S</i>	ft
<i>Clear height</i>	<i>H</i>	ft
<i>Exterior wall thickness</i>	<i>T_{EW}</i>	in.
<i>Interior wall thickness</i>	<i>T_{IW}</i>	in.
<i>Top slab thickness</i>	<i>T_T</i>	in.
<i>Bottom slab thickness</i>	<i>T_B</i>	in.
<i>Top haunch dimension</i>	<i>F_T</i>	in.
<i>Bottom haunch dimension</i>	<i>F_B</i>	in.

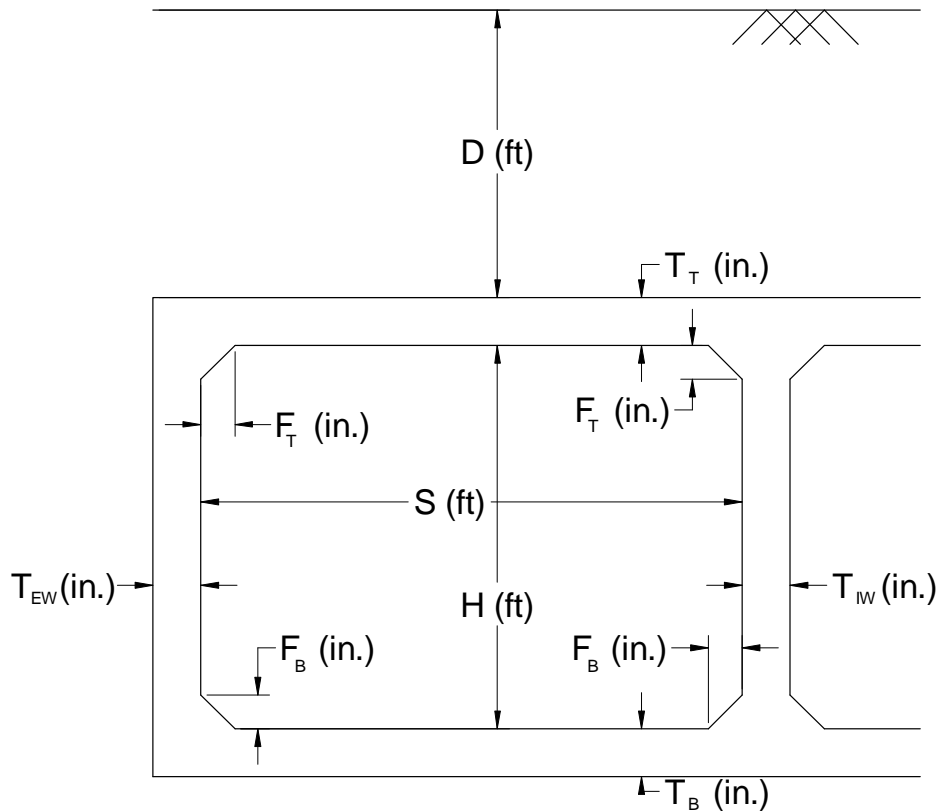

FIG 20. Culvert Dimensions.

D. DATA TYPICAL TO THE PROJECT FILE

Load rating parameters are typically captured from four classes of documents contained within the project file. These document classes are:

- NBI Coded Data (e.g., PonTex)
- Bridge Inventory Record and Revisions
- Construction Drawings (especially the design standard)
- Photos (typically from a Bridge Inspection Report)

Table 5 illustrates the data each class of documents will often provide. Further, this table illustrates how, in the case of a reasonably-complete project file where all four classes of documents exist, several parameters will likely be over-specified (identified in more than one document). Further, this table illustrates that some parameters exist only on certain documents, most notably the construction drawings.

It is appropriate to specifically comment about five of these parameters. The first is the design sheet (including the name). Given the importance of the design information to culvert load rating, and inasmuch as TxDOT project documents contain the design sheet only about half the time, Chapter 7 of this *Guide* provides details about how to address this parameter.

TABLE 5. Load Rating Parameters Required For Load Rating Calculations

NBI Coded Data (e.g., Pontex)	Bridge Inventory Record	Construction Drawings (incl. Design Standard)	Photos (typ. Bridge Inspection Report)
Document Dates	Document Dates	Document Dates	Document Dates
Span Number	Span Number	Span Number	Span Number
Span Length (ft)	Span Length (ft)	Span Length (ft)	Span Length (ft)
Box Height (ft)	Box Height (ft)	Box Height (ft)	Box Height (ft)
Cover Soil Depth (ft)	Cover Soil Depth (ft)	Cover Soil Depth (ft)	Cover Soil Depth (ft)
Year Built	Year Built	Year Built	Year Built
Haunches	Haunches	Haunches	Haunches
Skew	Skew	Skew	Skew
Design Sheet (incl. Name)	Design Sheet (incl. Name)	Design Sheet (incl. Name)	Design Sheet (incl. Name)
Lateral Stress Conditions	Lateral Stress Conditions	Lateral Stress Conditions	Lateral Stress Conditions
Design Year	Design Year	Design Year	Design Year
TxDOT Spec Year	TxDOT Spec Year	TxDOT Spec Year	TxDOT Spec Year
Pavement Type	Pavement Type	Pavement Type	Pavement Type
Soil Stiffness	Soil Stiffness	Soil Stiffness	Soil Stiffness
Reinforcing Steel Grade	Reinforcing Steel Grade	Reinforcing Steel Grade	Reinforcing Steel Grade
Concrete Class	Concrete Class	Concrete Class	Concrete Class
Condition Rating	Condition Rating	Condition Rating	Condition Rating
Comments	Comments	Comments	Comments

Soil stiffness and pavement type have already been identified as requiring special attention. Subsequent sections of this chapter, the accompanying example problems, and information in the CULVLR 2.0 software Help file provide details.

Finally, concrete class and reinforcing steel grade warrant special mention. The concrete class, which directly relates to the ultimate compressive strength and modulus of elasticity, is required for analysis. Likewise, the reinforcing steel grade, which directly relates to yield strength, is necessary. The load rater should use the best (i.e., most accurate) material property information available for the constructed culvert.

As-built construction documents (if available) will identify the build year for the culvert segment and often identify the concrete class. It is customary to rely on this information. In some cases, project-specific construction records including quality control data for concrete or mill certificates for reinforcing steel will be available. The load-rater should use the best available information.

The most common situation is that the build year for the structure is known, but the concrete class, steel grade and associated material properties are not directly available. In such cases, this *Guide* recommends that material properties be established from TxDOT specifications associated with the build year (not the design year). The Help file for CULVLR 2.0 contains a detailed technical memorandum which specifies the algorithm by which concrete and reinforcing steel properties are assigned. This approach is generally consistent with policy guidance from the *MBE* (see Table 1 and Table 2, Chapter 2 of this *Guide*).

In certain cases, it may be appropriate or helpful to obtain samples of the actual culvert materials and determine material properties based on laboratory tests. TxDOT test procedures published in the current Departmental Material Specifications specify how samples should be taken and how these types of tests should be performed.

E. QUALITY SCORE FOR PARAMETER IDENTIFICATION

Table 6 presents the rubric and calculation algorithm used to establish the quality score for interpretation of the key segment parameters. The table features six columns. The first column, Column (a), identifies the nine key parameters available from conventional data sources. Column (b) is a presence factor. Values are assigned 1.0 when a parameter is identified in the file but is assigned a value of 0.0 when missing. This emphasizes that each of these parameters is necessary for load rating. Column (c) assigns weighting factors to the parameters. While all parameters are important, two parameters – the design standard sheet and the presence or absence of haunches – are especially significant for load rating. Column (d) addresses the case where multiple documents identify a parameter but the values are in conflict. Usually the file is clear and parameter identification is non-controversial, but sometimes the parameter values from multiple documents conflict in such a way that resolution is not possible. Column (e) is a scaling factor applied so that the overall quality rating will be in the range of 0 to 5. The final column is the quality rating for each parameter calculated as the product of columns (b) through (e). The sum of the parameter scores is the interpreted parameter quality rating for the segment.

Table 6. Quality Score Rubric and Calculation Algorithm for Interpreted Parameters

Parameter	Presence Factor ^a	Weighting Factor	Conflict Resolution Factor ^b	Scaling Factor	Quality Rating
(a)	(b)	(c)	(d)	(e)	=b*c*d*e
Structure design	note a	1.5	note b	0.5	
Design sheet name	note a	1.0	note b	0.5	
Build year	note a	1.0	note b	0.5	
Number of spans	note a	1.0	note b	0.5	
Span length	note a	1.0	note b	0.5	
Box height	note a	1.0	note b	0.5	
Skew	note a	1.0	note b	0.5	
Haunches	note a	1.5	note b	0.5	
Cover soil depth	note a	1.0	note b	0.5	
Interpreted Parameter Quality Score (segment)					Σ ABOVE
^a Note: The presence factor is assigned based on the presence the parameter in the document file, as follows: = 1.0... present = 0.0... not present ^b Note: The conflict resolution factor is assigned based on the degree of confidence in the resolution, as follows: = 1.0... no conflict or high confidence in resolution = 0.5... moderate confidence in resolution = 0.0... little to no confidence in resolution					

The basic interpretive approach is rational in that *complete* and *unconflicted* parameter data corresponds to increased confidence in the quality of the assessment, and the relative quality score captures this effect. High scores (4 to 5) represent high quality data characterized by a generally complete set of segment parameters and few to no conflicts in the document record. The interpretation of such data was essentially clear and unambiguous. On the other end of the spectrum, low quality scores (0 to 2) represent segment data obtained from a document record fraught with holes or conflicts. Interpretation of such data was questionable.

Figure 21 summarizes the quality score for the interpreted parameter for all segments from the 1,000 Batch 1 culverts. Note that while Batch 1 culverts contained 1,788 segments, only 1,385 were ratable, and the percentages shown are based on ratable segments.

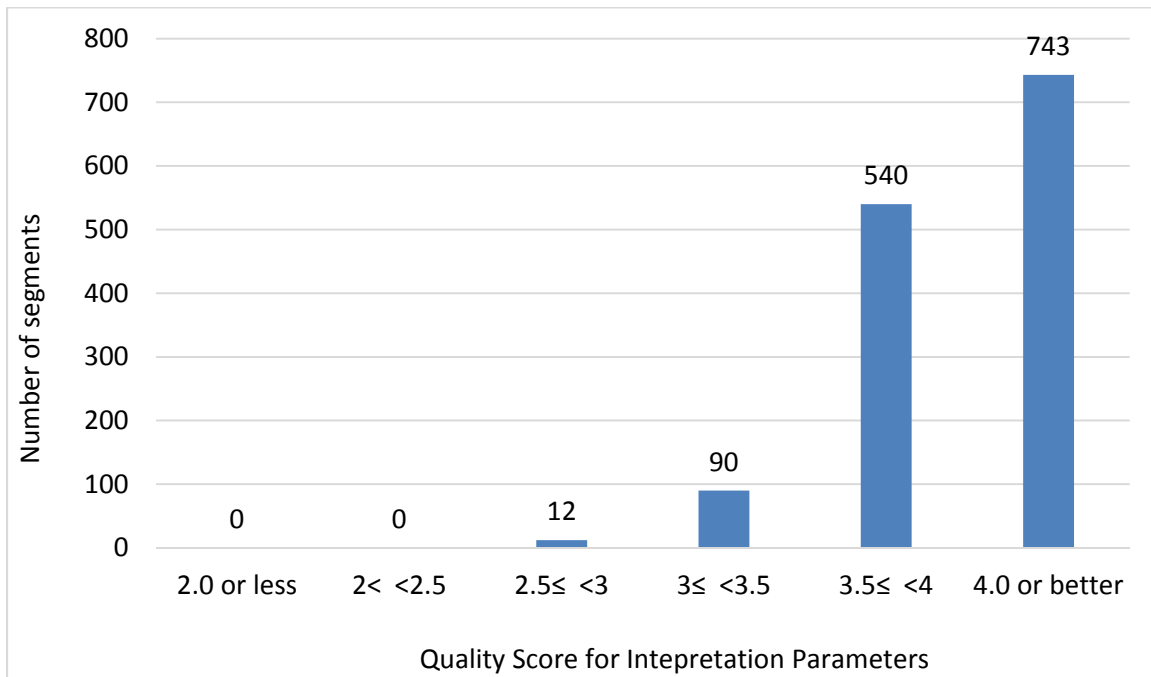

FIG 21. Quality Score for Interpretation Parameters, all Ratable Segments for Batch 1 Culverts

This figure reveals generally high confidence in the segment interpreted parameters, with 53.6 percent of Batch 1 ratable culvert segments having a score of 4.0 or better and 92.6 percent of Batch 1 ratable culvert segments having a score of 3.5 or better. No ratable segment had quality scores less than or equal to 2.0. Standard practice is to identify the best possible interpretation using the available data, realizing that lower quality data might be of questionable benefit. The interpreted parameter quality score documents this, but the decision of whether and how to use such results should be decided on case-specific considerations.

F. SOIL DATA

Soil parameters affecting culvert load rating primarily consist of the weight of soil around the culvert and the stiffness of soil used to provide bearing and lateral support to the culvert structure. The examples in this *Guide* (Appendix C) and the CULVLR 2.0 software illustrate how the load rating engineer may obtain soil information from the Web Soil Survey when soil data are otherwise not available. This section of the *Guide* provides technical details about the soil parameters for culvert load rating.

1. SOIL UNIT WEIGHT

Regardless of level of analysis, soil weight is one of the applied loads for the culvert loading model. In the case of a Level 1 analysis, it is the *only* required soil parameter. The unit weight of soil for culvert load-rating analyses is defined per AASHTO policy and presented in Table 1 and Table 2 (Chapter 2 of this *Guide*). Although it is possible to conduct a geotechnical exploration and directly measure the unit

weight of the soils which are over, around and beneath the culvert, this is rarely done for culvert load rating. Recommended practice is to use the AASHTO values for soil unit weight.

2. SOIL POISSON'S RATIO AND MODULUS

The Level 3 culvert load rating analysis accounts for soil-structure interaction effects by modeling soil using linear elastic finite elements. The soil parameters used to define these finite elements are Poisson's ratio and the modulus (i.e., Young's modulus) for both dead load and live load response.

As a general statement, the soil conditions above the culvert (vertical), beside the culvert (lateral), and below the culvert (bearing) are three zones which load rating engineers evaluate. It is possible to model different soil zones for each of these areas, to distinguish between native soil and backfill soil, and to introduce other refinements when delineating the soil model. In the absence of a project-specific subsurface soil profile establishing the soil zones, the load-rater may assume homogenous soil conditions around the culvert structure.

Given the stiffness of concrete box culverts, it is reasonable to assume that structure deflections will be very small and soil displacement will be correspondingly limited, thus the appropriateness of the linear-elastic approach. Of course, more sophisticated linear and non-linear soil constitutive models are available and can be used for specialized applications. These are discussed in Chapter 11 relative to Level 4 analyses. But for a Level 3 culvert rating calculation, the Poisson's ratio and elastic modulus parameters are sufficient.

a. POISSON'S RATIO

The Poisson's ratio, ν , for soil ranges from 0.10 to 0.50. An acceptable, recommended value is 0.30. Parametric analyses on a sample of TxDOT's culvert designs (Lawson *et al.* 2016) support the use of 0.3 for Poisson's ratio, with one exception. Inventory ratings for deep fill culverts (fill heights greater than 6 feet) with large wall heights (greater than 8 feet) are sensitive to Poisson's ratio. For these conditions, it would be appropriate to determine Poisson's ratio based on knowledge of the actual soil backfill type. Published data (Bowles, 1996) suggest that clayey backfill soils for deep fill/large wall height culverts should be modeled using a Poisson's ratio of 0.50, and sandy backfill soils for such culverts should be modeled using a Poisson's ratio of 0.30.

b. SOIL STATIC MODULUS (DEAD LOAD)

The static soil modulus, E_{soil} , is used represent the soil behavior suitable for dead load soil-structure response. To identify this value, the research upon which this *Guide* is based considered the culvert design family, the cover soil condition, and the typical range of soil modulus values observed in literature.

Relative to culvert design, the medium and large-sized culverts are more representative of TxDOT's population and were given priority. Relative to cover soil depth, direct traffic culverts (0 to 2 ft of fill) comprise about 77% of TxDOT's rated culvert segments. Low-fill culvert segments (2 ft to 6 ft) comprise 18%, and culvert segments with greater than 6 ft of fill (*i.e.* deep fill) comprise 5% of rated segments. Thus, the low-fill and direct traffic conditions also warranted priority in the analysis. Relative to published values for soil modulus, lower values were prominent, nominally in the range of 2 to 12 ksi with actual values influenced by soil type, consistency/relative density, overburden depth, and other factors.

From the calibration study (Lawson *et al.* 2016), static soil modulus values corresponding to the lowest coefficients of variation range from 5 ksi to 15 ksi, average 10 ksi, and these values are specific to the medium and large culverts for direct traffic and low-fill conditions. All things considered, a calibrated elastic modulus of 10 ksi was selected as a reasonable choice for dead load calculations per the linear elastic soil-structure interaction model. The data did not support differentiation, so this dead load soil stiffness value is recommended without regard to soil type, overburden depth, or other factors.

c. SOIL RESILIENT MODULUS (LIVE LOAD)

The resilient modulus, M_R is the elastic modulus based on the recoverable strain under repeated loads. Repeated loading causes progressive plastic strain accumulation, which results in increasing deformation. Repeated loading also compacts the soils, which is beneficial, except when it results in pore water pressure increase. Resilient modulus is calculated as the ratio of repeated deviator stress to elastic strain. Due to similarities between loading frequency and soil strains associated with pavement response and culvert response, resilient modulus was selected as an appropriate choice for analyzing live loads on reinforced concrete box culverts under traffic.

Table 7 provides representative resilient modulus (M_R) values for low, medium, and high-strength soil, based mostly on synthesis of published values from technical literature. It is emphasized that modulus values vary widely for a given soil type and actual values depend on factors such as moisture content, unit weight, compressibility, stress level, etc. Use of this table requires at least a basic idea about the type of soil, expressed in terms of soil classification by ASTM, AASHTO, or TxDOT methods.

TABLE 7. Resilient Modulus of Soil for Level 3 Live Load Model.

Culvert Backfill Soil Description	Resilient Modulus M_R	Unified Soil Classification (ASTM D2487)	AASHTO Group Classification (AASHTO M 145)	Texas Triaxial Classification (TEX-117-E)
Low: Fine-grained soils in which highly-plastic silt and clay-sized particles predominate	<i>Range: 5 - 25.5 ksi</i> <i>Typical: 12 ksi</i>	CH, OH, MH, OL	A5, A6, A7, A8	> 5.0
Medium: Sands and sand-gravel mixtures with moderate amounts of silts and clay	<i>Range: 13.5 -37.5 ksi</i> <i>Typical: 24 ksi</i>	CL, ML, SC, SP, SM	A3, A4	3.5 to 5.0
High: Gravels and sand-gravel mixtures relatively free of plastic fines	<i>Range: 24 -42 ksi</i> <i>Typical: 36 ksi</i>	GW, GP, GM, GC, SW	A1, A2	< 3.5
Lawson et al. 2009, AASHTO 2008				

In the absence of culvert-specific data, the M_R values in Table 7 may be correlated from the USCS or AASHTO soil classifications. The practical necessity of categorizing culvert soils into low, medium, and high stiffness materials is a major simplification. Further, the modulus values in Table 7 are reasonable choices for live load demand predictions for culvert load rating and are not inconsistent with the production-simplified soil-structure interaction model.

Of course, site-specific determination of the soil modulus is desirable for culvert load rating applications. Modulus values for soils may be estimated from empirical correlations, laboratory test results on undisturbed specimens, and from results of field tests. Laboratory tests that may be used to estimate the soil modulus are the California Bearing Ratio test, unconsolidated-undrained triaxial compression test, or the consolidated-undrained triaxial compression tests. Field tests include the static cone penetration test (CPT), standard penetration test (SPT), Texas cone penetrometer (TCP), dynamic cone penetrometer (DCP) test, falling weight deflectometer (FWD) test, and the pressuremeter test (PMT).

Parametric analyses on a sample of TxDOT's culvert designs show that the culvert inventory rating is sensitive to the soil modulus value used for demand calculations, especially for deep-fill culverts (fill heights greater than 6 feet). Data from a limited culvert instrumentation and field test program (three culverts having different types of drained soil backfill) suggest that TxDOT's culverts are typically backfilled with on-site soil excavated during the culvert construction process. Superior backfill material should not be assumed without verification. Among the approaches identified above to determine modulus, data suggest that the falling weight deflectometer (FWD) provides the most reliable and repeatable soil modulus values.

G. PAVEMENT DATA

Pavement affects culvert load rating primarily by the manner in which the pavement structure – which is generally stiffer than soil – attenuates live load stresses that ultimately produce the culvert structural response. The examples in this *Guide* (Appendix C) and the CULVLR 2.0 software illustrate how the load rating engineer may identify the pavement type from the TxDOT Pavement Management Information System (PMIS) when pavement data are otherwise not available. This section of the *Guide* provides technical details about the pavement parameters used for culvert load rating.

The research supporting this *Guide* identified, calibrated, and applied a simplified pavement model for production load rating of culverts that includes and accounts for the influence of the pavement structure on load rating analyses. Table 8 shows the simplified pavement model for each of the three categories of soil stiffness described in the previous section.

This model uses TxDOT's PMIS pavement types as the basis for the equivalent beam model. To achieve this transformation, nominal thicknesses and moduli of pavement structures of each category were determined based on the extensive literature on typical design modulus values and thicknesses of pavement layers in Texas. Detailed procedures were then used to calibrate the equivalent pavement model suitable for production-simplified load rating.

The modulus values in Table 8 are reasonable choices for live load demand predictions for culvert load rating and are not inconsistent with the production-simplified soil-structure interaction model. Of course, actual values will vary from culvert to culvert, even for the same pavement type.

TABLE 8. Equivalent Modulus for Simplified Beam Model for Pavement

Type	Description	Equivalent beam modulus, $E_{eq,beam}$ (ksi)		
		$E_{soil} =$ 12 ksi	$E_{soil} =$ 24 ksi	$E_{soil} =$ 36 ksi
1	Continuously Reinforced Concrete Pavement (CRCP)	34,000	32,000	29,500
2	Jointed Reinforced Concrete Pavement (JRCP)			
3	Jointed Plain Concrete Pavement (JPCP)			
4	Thick Asphaltic Concrete Pavement (greater than 5-1/2")	890	630	520
5	Intermediate Thickness Asphaltic Concrete Pavement (2-1/2" to 5-1/2")	720	460	340
6	Thin Surfaced Flexible Base Pavement (less than 2-1/2")	255	130	75
7	Asphalt Surfacing with Heavily Stabilized Base	580	390	310
8	Overlaid and/or Widened Old Concrete Pavement	58,000	55,000	53,000
9	Overlaid and/or Widened Old Flexible Pavement	1250	660	430
10	Thin Surfaced Flexible Base Pavement (Surface Treatment-Seal Coat)	50	21	11

Site-specific determination of the pavement thicknesses and modulus values may be desirable for certain culvert load rating applications. Thickness is typically established by destructive testing (coring) the as-built pavement structure and directly measuring the layers. Modulus values may be estimated from laboratory test results on undisturbed specimens or from results of field tests. Such an approach will require direct modeling of the pavement structure rather than use of the equivalent beam model identified herein.

H. CULVLR 2.0 SOFTWARE – PARAMETER INTERPRETATION AND DATA CAPTURE

Parameter interpretation and data capture, which is the third task of the culvert load rating process, is where the load rating engineer identifies his/her best interpretation for each parameter necessary to specify each segment of a given culvert structure for load rating purposes. Data input for CULVLR 2.0 directly engages this step. Inputs are largely descriptive, allowing the load rater to document with clarity all parameters for the particular culvert segment being load-rated.

I. EXAMPLE PROBLEM – PARAMETER INTERPRETATION AND DATA CAPTURE

Appendix C of this *Guide* presents a worked example for parameter interpretation and data capture.

7. DESIGN SELECTION

A. DESIGN SELECTION FOR CULVERT LOAD RATING

Culvert load rating requires an analytical model to calculate both capacities and load demands, and the interpreted parameters task (discussed in Chapter 6) emphasizes the priority and importance of having the actual design drawing available when specifying the analytical model for a culvert segment. From the perspective of the load rating engineer, the project file will contain the design used to construct a particular culvert segment, or it will not. When the design is available it can be digitized for load rating purposes, and this must be done for each critical section of the culvert structure – which is highly-detailed, painstaking work. If the design is *not* available, the load rating engineer must either obtain the design information by some other means, or s/he must terminate the project due to lack of information.

However, one of the idiosyncrasies of TxDOT’s historical practice associated with culverts is the agency’s strong reliance on engineered design standards (Figure 22). That is, rather than uniquely create each culvert design for every project, over the years TxDOT engineers created sets, or families, of engineered standards to address several of the most common applications.

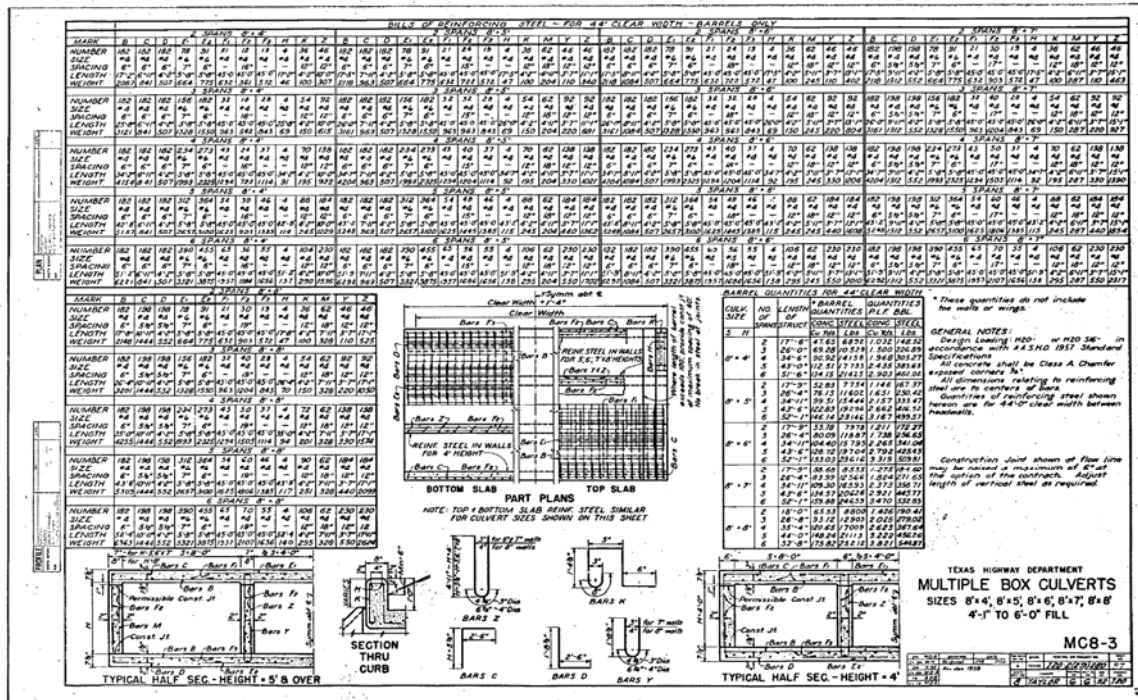

FIG 22. TxDOT Culvert Design Standard: Original Design ('MC8-3')

Owing to internal design repeatability within each family of culvert standards, it is therefore possible to associate (or correlate) a particular design with basic culvert parameters such as design year, number of spans, span length, box height, cover soil depth, etc. This means that today, when the culvert document file does not contain the design, the load rating engineer can use known information about the culvert segment; *i.e.*, its unique set of parameters, to identify particular standard designs that “match.”

Further, as will be discussed herein, one of the beneficial features of the CULVLR 2.0 software accompanying this *Guide* is that the software contains a “digital design collective” of TxDOT’s pre-1980 culvert standards. That is, all the available pre-1980 design standards have been digitized for load rating and parameterized for identification. This chapter describes TxDOT’s population of culvert standard designs, briefly outlines the process by which these standard designs were pre-digitized to form the “digital design collective,” and provides guidance about how to accomplish load rating Task 4, which is design selection.

B. TxDOT’S USE OF DESIGN STANDARDS

Since the earliest days of the Texas Highway Department (chartered 1916), TxDOT created and has relied on standard designs for their multi-span, bridge-class culvert structures. TxDOT’s archive files revealed design standards dating to the 1920s, and multiple generations of these design standards exist. Implementation of the standard designs allowed TxDOT bridge engineers to rapidly specify repeated culvert designs rather than invest the intensive effort and expense needed to create custom designs for each specific structure and application, one culvert at a time. These culvert design standards are an elegant expression of engineering efficiency, repeatability and utility.

TxDOT’s population of culvert designs focus on multiple-span culvert structures, sometimes referred to as multiple box culverts (MBCs), all of which are cast-in-place reinforced concrete. An individual design standard sheet defines the configuration for various geometries of culverts under different cover soil depths, along with details of reinforcing steel and concrete strength. As such, the design standard fully prescribes the structural capacity of the culvert.

C. CULVERT DESIGN ERAS

Individual design standard sheets are typically associated with a specific era, design philosophy, material specification, allowable cover soil depth range, design load, and culvert span length. Within this context, the design standard will present a representative cross section identifying culvert member dimensions (Figure 23a) and the reinforcing steel layout, along with multiple tables (20 to 30, typical) defining specific design options for a range of culvert wall heights and number of spans (Figure 23b). As project needs and policy requirements developed, the standard designs changed, evolved, and were replaced. The result was several eras of culvert standard designs.

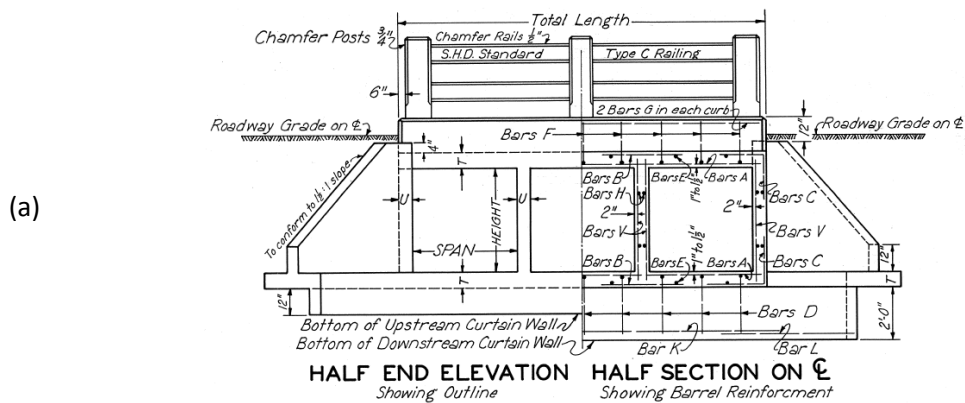

(b)

BILL OF STEEL FOR MULTIPLE 5'x5' BOX CULVERTS																							
4 SPANS																							
Bars	A	B	C	D	E	F	G	H	H1	H2	H3	J	K	L	M	N1	N2	V	V1	V2	V3	V4	V5
No.	104	288	192	12	16	12	4	28	4	4	8	2	4	12	26	26	155	24	12	12	8	8	
Size	1/2"	1/2"	1/2"	1/2"	1/2"	1/2"	1/2"	1/2"	1/2"	1/2"	1/2"	1/2"	1/2"	1/2"	1/2"	1/2"	1/2"	1/2"	1/2"	1/2"	1/2"	1/2"	1/2"
Spacing	5 1/2"	5 1/2"	5 1/2"	18"	~	18"	12"	18"	18"	18"	18"	3 1/2"	~	~	~	9 1/2"	9 1/2"	9"	6"	6"	6"	12"	12"
Length	22'5"	3'10"	4'5"	25'8"	22'6"	24'0"	22'5"	22'6"	6'0"	8'9"	11'3"	12'6"	23'0"	13'0"	13'0"	3'4"	4'4"	5'10"	7'6"	6'3"	5'8"	4'6"	3'3"
Weight	2004	951	729	204	237	191	60	416	16	23	30	66	30	34	103	57	75	596	119	50	45	24	17

FIG 23. Detailed Specification, 4-span, 5' x 5' box culvert, TxDOT Culvert Design Standard 'MBC-3'

TxDOT culvert standards developed over six fairly distinct eras: 1) early standards, 2) pre-WWII standards, 3) Interstate Highway standards, 4) modernized Interstate Highway standards, 5) 2003 design standards, and 6) 2014 LRFD standards. Table 9 shows a summary of TxDOT design standards identified in this study.

Table 9. Classification of TxDOT design standards by era

Design Era	TxDOT Culvert Design Standards	No. of design sheets
1. Early standards	MBC-## (oldest... 1920s-30s)	30
2.a pre-WWII standards (direct traffic)	MBC-##-## (haunched 1930s-40s)	41
2.b pre-WWII standards (fill)	MBC-##-##-F (haunched 1930s-40s)	85
2.c Single box designs	BC-## (haunched... 1930s)	7
3. Interstate Highway standards	MC##-# (newest... 1949-1977)	68
4. Updated Interstate Highway	MC##-# (reissued... 1977 onward)	68
5. 2003 Release	Redesigned standards	25
6. 2014 Release	Updated for LRFD	n.p.

The early standards (c.1900-1920s) tended to be unhaunched, and some few culverts built this era are still in service. The pre-WWII standards (c.1920s-1940s) were smaller (typical spans less than 8ft) and employed haunched corners. The Interstate Highway standards (c.1949-1977) were unhaunched with thinner slabs and longer spans (9-10ft). These design features were intended to reduce construction material and labor cost. The Interstate Highway designs were “modernized” and reissued in 1977 by increasing the design steel strength from Grade 40 ($F_y = 40\text{ksi}$) to Grade 60 ($F_y = 60\text{ksi}$). These modernized Interstate Highway standards (1977-2002) were the first to be evaluated using current load factor design procedures requiring HS-20 loading conditions. In 2003, TxDOT redesigned, expanded, and issued a complete set of culvert construction drawings. The 2003 set includes new designs for deep fill culverts with fill heights up to 23 feet. TxDOT again updated their culvert design standards for LRFD, resulting in a sixth era (c. 2014), but information was not provided about this set of designs.

In addition to era, TxDOT culvert design standards can be categorized depending on degree of deviation of their design details from the original standard designs. These categories are: 1) original design standards, 2) modified design standards, and 3) structure-specific designs.

Because the emphasis of this *Guide* is pre-1980 culverts not specifically designed for HS-20 loading, most of the discussions which follow focus on the first three eras of TxDOT’s culvert standards. Also, Table 9 includes a category for single-span culverts. These single-span designs are part of the second era

of TxDOT’s design standards and are of interest for this research since single-span designs, while not bridge-class culverts by themselves, were sometimes lengthened or used to lengthen in-service multi-span culverts.

D. TxDOT’S FAMILIES OF STANDARD CULVERT DESIGNS

The different TxDOT design eras resulted in design standards having similar characteristics including a specific design philosophy and unique design distinctions. For this reason, it is natural to think of the designs for a specific era as a “family” of standard designs. Table 10 presents a summary of the identifying characteristics of the original design standards families for TxDOT culverts. In addition to the family name, the typical span length, box height, number of spans, and cover soil depth are identified. These data provide a comprehensive picture of the diversity of TxDOT’s population of available culvert designs.

The degree to which these culvert design standards are currently in use is of interest. Based on analysis of the sample of 1,000 (Batch 1) culverts, approximately 58 percent of TxDOT’s pre-1980 in-service culvert segments use MC designs (Interstate Highway era). The next closest group is MBC-#, at 16 percent. As would be expected, the pre-WWII standards, while still in use, are represented less prominently among the in-service culvert segments, at 26 percent of the population.

Table 10. Summary of TxDOT original design standards families

Design Family	Span Length (ft.)	Box Height (ft.)	No. of Spans	Cover soil depth	Characteristics
MBC-#	3 – 10	3 – 10	2 - 7	0 – 8 ft.	<ul style="list-style-type: none"> • Unhaunched • Expansion slab • Design year ranging from 1924 to 1928
MBC-##	5 - 10	2 – 12	2 - 9	0-2 ft. (Direct traffic)	<ul style="list-style-type: none"> • Haunched • Expansion slab • Design year ranging from 1935 to 1940
MBC-##-F	5 – 10	2 – 12	2 - 9	2-6 ft. (Low fill type)	<ul style="list-style-type: none"> • Haunched • No expansion slab • Design year ranging from 1935 to 1940
BC-#	2 - 10	1.5 – 10	1	4 – 30 ft.	<ul style="list-style-type: none"> • Haunched • Single barrel • Design year ranging from 1934 to 1936
MC#-#	5 – 10	5 – 10	2 - 6	<ul style="list-style-type: none"> • MC5/6-1: 0-4 ft. • MC5/6-2: 4-6 ft. • MC7/8/9/10-1: 0-2ft • MC7/8/9/10-2: 2-4ft • MC7/8/9/10-3: 4-6ft 	<ul style="list-style-type: none"> • Unhaunched • Design year ranging from 1949 to 1977

E. DIGITIZATION OF DESIGN STANDARDS – “DIGITAL DESIGN COLLECTIVE”

Collectively, TxDOT’s pre-1980 culverts represented a total of 416 design sheets, representing 9,362 individual culvert designs. Among the 416 design standard sheets, 231 sheets were original design

standards and 36 were modified design standards. The remaining 149 design sheets were structure-specific designs.

Parameter take-offs for all culvert design standards were performed, and data entry of the reinforcing steel schedule, mapping reinforcing steel bar marks, and concrete cover thicknesses followed. Because of the digitization efforts, these culvert designs can be associated with basic culvert index parameters such as design year, number of spans, span length, box height, etc. This allows the systematic identification of an “associated” culvert design when the original design is not available from source documents. Further, the digitized design data directly facilitated computations of the capacity and load rating at each critical section of the culvert.

F. THE “DESIGN SELECTION” TASK

In recognition that engineers who use this *Guide* will also likely use the CULVLR 2.0 software – including the *digital design collective* – the task of design selection for culvert load rating can be viewed somewhat like an ordered algorithm.

The first (ideal) scenario is when all culvert segment information exists and the design is pre-digitized. Based on data from 1,000 culverts, this scenario occurs about 40% of the time, with another 14% of cases where the design is not in the file but is fully identified. The first step of design selection is *always* for the load rater to determine whether the culvert document file contains the design. If yes, the load rater must digitize the design. However, for pre-1980 culverts it is likely (90 to 95% of the time) the design already exists within the digital design collective of CULVLR 2.0. Thus the load rater should check, and if the design is pre-digitized the load rater may simply select the design. Design selection is complete. The load rater may proceed to the next step in the load rating process, which is Level 1 (or perhaps Level 3) load rating.

What if the culvert document file contains the design standard used to construct the culvert, but the design does not appear in the digital design collective of CULVLR 2.0? Based on data from 1,000 culverts, this scenario occurs less than 10% of the time. Here the load rater may use CULVLR 2.0 to help digitize the specific design of interest. This work involves careful reading and interpretation of the design standard, followed by inputting detailed culvert geometry, bar marks, the bar map (a cross section of culvert reinforcing steel), and material property information. Once these subtasks are performed, CULVLR 2.0 will auto-specify all culvert design data for each critical section of the structure. Design selection is complete. The load rater may proceed to the next step in the load rating process, which is Level 1 (or perhaps Level 3) load rating.

A third scenario (fairly common) is when the culvert document file does not contain the design. Based on data from 1,000 culverts, this scenario occurs about 36% of the time. That is, the load rater identifies all the basic parameters for the culvert segment (load rating Task 3) but no design is available. In this case, the load rater may use the identified parameters to search for a design match among the pre-digitized designs within the digital design collective of CULVLR 2.0. If a reasonable match exists, the load rater may simply select the design and this is termed “design association.” Design selection (via association) is complete. The load rater may proceed to the next step in the load rating process, which is Level 1 (or perhaps Level 3) load rating.

A fourth scenario is when the culvert document file does not contain the design and the load rater’s search using the digital design collective does not yield a reasonable match. Situations where this tends

to occur are (a) deep fill culverts, (b) unusual culvert geometry and (c) very old culverts. Also, it is important to remember that CULVLR 2.0 was specifically created to handle cast-in-place reinforced concrete box culvert structures. The program does not process any “non-box” cross sections such as circular pipes, ellipses, three-sided arches, expansion slabs, etc. Further, the capacity and demand calculation algorithms in CULVLR 2.0 only allow cast-in-place reinforced concrete and do not process pre-cast concrete, wood, metal, thermo-plastic, masonry, etc. These types of situations occur about 12% of the time. In such cases, the load rating engineer is left to explore alternative methods for load rating. Likely this will involve more fundamental effort, starting with *MBE* guidance and including unique, project-specific structural models.

As a general statement, design selection represents a key decision in the culvert load rating process. Thus it is appropriate to document the interpretation of segment design selection by means of a 5-point quality rating. This is particularly true when the design is identified by “association,” and the next section of this *Guide* discusses the quality of such selections.

G. SEGMENT DESIGN IDENTIFICATION - QUALITY RATING PROCESS

A design is necessary for each and every culvert segment to be load rated. As would be expected, when the culvert file provides the actual design sheet with no conflicting information, this “provided” sheet is simply identified for the segment. However, sometimes the culvert file does not contain the design sheet and when this occurs, the design sheet must be “associated” based on a parameter matching process. The “associated” design can then be identified to facilitate load rating the segment, but some associations are stronger than others. It is this associative process that gives rise to the need for a quality rating for the design selection.

The segment design identification quality rating provides a way to assess the reliability of the design assigned to each segment of a culvert structure. The quality rating is based on the completeness of the key segment parameters, employs weighting factors, and systematically quantifies and scales the design match. Possible matches of design sheets for a segment are assessed and awarded a score, and the scores are weighted and summed for an aggregated quality score. Table 11 presents the rubric and calculation algorithm used to establish the quality score which is performed in three stages. The first stage is a quantity assessment. The second stage is a scaling assessment. The third stage is design match assessment.

Table 11. Quality Score Rubric and Calculation Algorithm for Segment Design Selection

Quality Rating	Completeness of the design match (50%)	Importance of any non-matching data (25%)	Number of possible design matches (25%)
(a)	(b)	(c)	(d)
5	Design <OR> 8/11	Design <OR> No Missing Data	Design <OR> 1
4	6 – 7/11	Skew, Cover Soil Depth	2 - 3
3	5 /11	Name, Design Year, Revision Year	4 – 6
2	4/11	Build Year	7 – 10
1	≤ 3/11	Number, Height and Length of Span, Haunch	≥11

The first stage of the design selection quality assessment (Column b) assesses the completeness of the available segment data. This stage uses eleven segment parameters as follows: (1) the presence of a design document for the segment, (2) the name of the design used for the segment, (3) the original year of the design, (4) the revised year of the design, (5) the build year for the segment, (6) the number of spans of the segment, (7) span length of the segment, (8) box height of the segment, (9) the skew of the segment, (10) haunches for the segment- if present, and (11) the cover soil depth selected to analyze the segment. Each parameter is given a score of 1 and the sum of the scores is weighted at 50% of the total quality score for segment level design selection.

The second stage scales the information derived from the design selected. The scale quantifies the importance of non-matching design and segment interpreted parameter data. When there are no non-matching data, a score of 5 is assigned. When the skew or cover soil depth of the segment do not match the design selected, a score of 4 is assigned. When the name or design year of the design selected do not match the information provided by the segment source documents, a score of 3 is assigned. When the design year precedes the year the segment was constructed, a score of 2 is assigned. When the number of spans, span length, box height, or presence or absence of haunches are not indicated, a score of 1 is assigned. This assigned score is weighted at 25%.

The third stage assesses the possible number of designs matching the segment. The larger the number of possible designs, the lower the quality score. If there is only one possible design match, a score of 5 is assigned. Possible matches are sorted using information provided, specified or interpreted for the segment source documents. For 2 – 3 possible matches, a score of 4 is assigned. For 4 – 6 possible matches, a score of 3 is assigned. If 7 – 10 possible matches exist, a score of 2 is assigned. If there are 11 or more possible matches, a score of 1 is assigned. This assigned score is weighted at 25% percent.

The weighted scores from all three assessment stages are combined to calculate the overall quality score for segment level design selection. The basic interpretive approach is rational in that a *complete* and *unique* parameter set corresponds to increased confidence in the quality of the design selection, and the relative quality score captures this effect. High scores (4 to 5) – especially the case where the actual design is provided – represent high confidence in the design selection process. The interpretation of such data is essentially clear and unambiguous. On the other end of the spectrum, low quality scores (1 to 2) represent design selections obtained from a document record with significant missing data and thus many potentially-viable design options. The segment design selection in this case is questionable.

Figure 24 summarizes the quality score for design selection for all segments from the 1,000 Batch 1 culverts. Recall that while Batch 1 culverts contained 1,788 segments, only 1,385 were ratable, and the percentages shown are based on ratable segments.

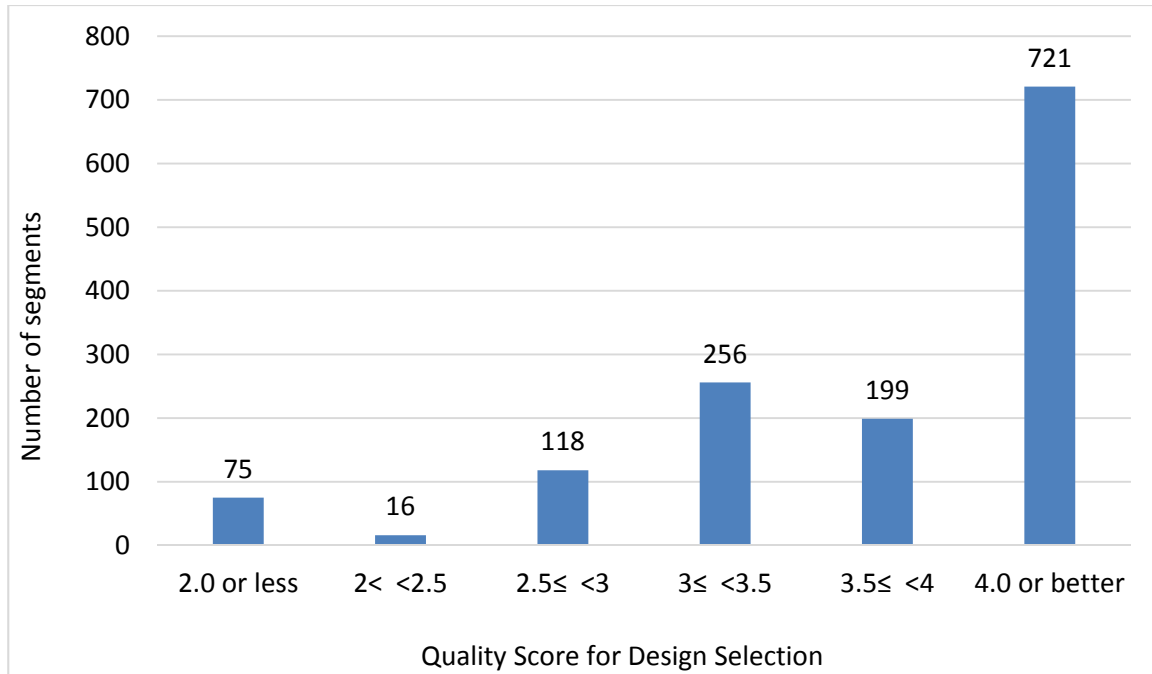

FIG 24. Quality Score for Design Selection, all Ratable Segments for Batch 1 Culverts

This figure reveals generally high confidence in the segment design selection, with 52 percent of Batch 1 ratable culvert segments having a score of 4.0 or better and 85 percent of Batch 1 ratable culvert segments having a score of 3.0 or better. Only 5 percent had quality scores less than or equal to 2.0. The load rater should always identify the best possible interpretation using the available data, realizing that lower quality data might be of questionable benefit. The interpreted parameter quality score documents this, but the decision of whether and how to use such results is addressed on a case-by-case basis.

H. CULVLR 2.0 SOFTWARE – DESIGN SELECTION

Design selection, which is the fourth task of the culvert load rating process, is where the load rating engineer selects the design in order to completely specify the analytical model for a given culvert segment for load rating purposes. Data input for CULVLR 2.0 directly engages this step and includes the benefits of the digital design collective. Inputs focus on the presence or absence of the design, and in cases where the project file does not include the design, the load rater focuses on associating the design based on matching parameters for the particular culvert segment being load-rated.

I. EXAMPLE PROBLEM – DESIGN SELECTION

Appendix D of this *Guide* presents a worked example for design selection.

8. CULVERT CAPACITY CALCULATIONS

A. POLICY FOR CAPACITY CALCULATIONS

The AASHTO *Manual for Bridge Evaluation, 2nd Edition (MBE)*, Section 6B, provides technical guidance on load rating of existing bridges per the load factor rating (LFR) method. Further, *MBE* article 6B.5.3 directs the load rater to the AASHTO *Standard Specifications for Highway Bridges (SSHB)*, *Seventeenth Edition* for details of the capacity calculations. Thus, most sections of this chapter of the *Culvert Rating Guide* cite the *SSHB*.

The *SSHB* provides equations to determine section capacities for each potential failure mode; that is, bending moment, shear, and axial thrust. These section capacities, C , are used in Equation 1 when calculating the culvert rating factors. *SSHB* Section 8.16.3 discusses flexural capacity calculations considering maximum reinforcing limits in the terms of the balanced reinforcement ratio. The capacity discussion is split between singly and doubly reinforced beams. *SSHB* Section 8.16.4 provides guidelines for determining the thrust capacity. *SSHB* Section 8.16.4.3 in particular provides an equation for checking that the thrust load is small enough to not control over moment. *SSHB* Section 8.16.6.7 provides a complex equation for determining the shear capacity based on both the shear and moment demands. This equation has very simple upper and lower limits that may be used when shear does not control.

This section of the *Guide* discusses how to apply AASHTO policy to calculate section capacities as part of the culvert load rating process. The section capacity must be calculated for each failure mode (bending moment, shear, axial thrust) at each critical section of the culvert defined in Figure 6. The gross section properties are used to calculate the capacity of the culvert structure.

B. SIGN CONVENTION FOR LOAD RATING CALCULATIONS

The sign convention that will be used throughout this document is that the layer of the steel on the inside of the culvert is placed in tension during positive bending, while the outside layer of steel is placed in the tension during negative bending. Stated another way, when the tension face is *inside* the culvert, bending is positive. When the tension face is *outside* the culvert, bending is negative.

C. BENDING MOMENT CAPACITY

Bending moment capacity must be calculated in each bending direction; that is, both positive and negative. Bending moment capacity may be determined using the following steps which have been derived to follow the AASHTO provisions in the *SSHB*. For reference, the *SSHB* equation number is shown in parenthesis in the equation identifier.

Capacity Step 1. Determine the centroid of the section at ultimate capacity using Equation 3.

EQ 3. CENTROID OF THE SECTION AT ULTIMATE CAPACITY (DERIVED FOR *SSHB* 8.16.3.4).

$$c = 0.5 \left\{ -\frac{(87,000 - 0.85f'_c)A'_s - F_y A_s}{0.85f'_c \beta_1 b} + \sqrt{\left[\frac{(87,000 - 0.85f'_c)A'_s - F_y A_s}{0.85f'_c \beta_1 b} \right]^2 + 4 \left[\frac{87,000 A'_s d'}{0.85f'_c \beta_1 b} \right]} \right\}$$

where:

c	=	the centroid of the section (in.)
F_y	=	yield strength of the reinforcement (psi)
f'_c	=	the compressive strength of concrete (psi)
A_s	=	area of the tension reinforcement (in. ²)
A'_s	=	area of the compression reinforcement (in. ²)
d'	=	distance from the extreme compression fiber to the centroid of the compression reinforcement (in.)
b	=	width of the compression face member (typically 12 inches)
β_1	=	0.85 when $f'_c \leq 4,000$ psi
	=	$1.05 - f'_c * (.0005)$ when $4,000$ psi $\leq f'_c \leq 8,000$ psi
	=	0.65 when $f'_c \geq 8,000$ psi from <i>SSHB</i> 8.16.2.7

Capacity Step 2. Calculate the stress in the compression steel using Equation 4.

EQ 4. STRESS IN THE COMPRESSION STEEL (PSI) (DERIVED FOR SSHB 8.16.3.4).

$$0 \leq F'_s = 87,000 \frac{c - d'}{c} \leq F_y$$

where:

F'_s	=	the stress in the compression steel (psi)
F_y	=	yield strength of the reinforcement (psi)
c	=	the centroid of the section (in.)
d'	=	distance from the extreme compression fiber to the centroid of the compression reinforcement (in.)

Capacity Step 3. Calculate the balanced stress in the compression steel using Equation 5. However, if F'_s equals zero (established from Capacity Step 2) then F'_b equals zero and the load rater may proceed to Capacity Step 4.

EQ 5. STRESS IN COMPRESSION STEEL AT BALANCED STEEL (SSH B 8.16.3.4.3 EQ.8-28).

$$F'_b = 87,000 \left[1 - \frac{d'}{d} \left(\frac{87,000 + F_y}{87,000} \right) \right] \leq F_y$$

where:

F'_b	=	the stress in the compression steel (psi)
F_y	=	yield strength of the reinforcement (psi)
c	=	the centroid of the section (in.)
d	=	distance from the extreme compression fiber to the centroid of the tension reinforcement (in.)
d'	=	distance from the extreme compression fiber to the centroid of the compression reinforcement (in.)

If $F'_s = 0$ then $F'_b = 0$

Capacity Step 4. Calculate the balanced steel ratio using Equation 6.

EQ 6. RHO BALANCED FOR DOUBLY REINFORCED SLABS (SSHB 8.16.3.4.3 EQ8-27).

$$\rho_b = \frac{0.85\beta_1 f'_c}{F_y} \left(\frac{87,000}{87,000 + F_y} \right) + \frac{A'_s F'_b}{bdF_y}$$

where:

ρ_b	=	the balanced ratio of tensile reinforcement
f'_c	=	the compressive strength of concrete (psi)
F_y	=	yield strength of the reinforcement (psi)
F'_b	=	the stress in the compression steel (psi)
A'_s	=	area of the compression reinforcement (in. ²)
d	=	distance from the extreme compression fiber to the centroid of the tension reinforcement (in.)
b	=	width of the compression face member (typically 12 inches)
β_1	=	0.85 when $f'_c \leq 4,000$ psi
	=	$1.05 - f'_c * (.0005)$ when $4,000$ psi $\leq f'_c \leq 8,000$ psi
	=	0.65 when $f'_c \geq 8,000$ psi from SSHB 8.16.2.7

Capacity Step 5. Check the balanced steel ratio using Equation 7.

EQ 7. MAXIMUM REINFORCING CHECK (DERIVED FROM SSHB 8.16.3.1.1).

$$\rho = \frac{A_s}{bd} \leq 0.75\rho_b$$

where:

ρ	=	the ratio of tensile reinforcement
A_s	=	area of the tension reinforcement (in. ²)
b	=	width of the compression face member (typically 12 inches)
d	=	distance from the extreme compression fiber to the centroid of the tension reinforcement (in.)
ρ_b	=	the balanced ratio of tensile reinforcement per Equation 6

Capacity Step 6. Calculate the moment capacity using Equation 8 or Equation 9.

EQ 8. GENERALIZED MOMENT CAPACITY (DERIVED FROM *SSHB* 8.16).

$$\phi M_n = \phi \left\{ (A_s F_y - A'_s F'_s) \left[d - \frac{A_s F_y - A'_s F'_s}{2(0.85) f'_c b} \right] + A'_s F'_s (d - d') \right\} \left(\frac{'}{12''} \right) \left(\frac{\text{kip}}{1000\text{lb}} \right)$$

where:	ϕM_n	=	the bending moment capacity of the section (kip-ft/ft)
	ϕ	=	0.9 = the strength reduction factor from <i>SSHB</i> 16.6.4.6
	f'_c	=	the compressive strength of concrete (psi)
	F_y	=	yield strength of the reinforcement (psi)
	F'_s	=	the stress in the compression steel (psi)
	A_s	=	area of the tension reinforcement (in. ²)
	A'_s	=	area of the compression reinforcement (in. ²)
	d	=	distance from the extreme compression fiber to the centroid of the tension reinforcement (in.)
	d'	=	distance from the extreme compression fiber to the centroid of the compression reinforcement (in.)
	b	=	width of the compression face member (typically 12 inches)

If no tensile steel reinforcing is provided, the moment capacity may be taken as the cracking moment such that any incidental moment in the unreinforced direction does not result in an over-conservative controlling load rating. This should be calculated using Equation V-7.

EQ 9. MINIMUM CRACKING MOMENT CAPACITY.

$$\phi M_n = \phi h^2 \sqrt{f'_c} \left(\frac{\text{kip}}{1000\text{lb}} \right)$$

where:	ϕM_n	=	the bending moment capacity of the section (kip-ft/ft)
	ϕ	=	0.9 = the strength reduction factor from <i>SSHB</i> 16.6.4.6
	f'_c	=	the compressive strength of concrete (psi)
	h	=	the thickness of the total section (in.)

D. SHEAR CAPACITY

Shear capacity must be calculated at each critical section as defined in Figure 8. Technically these are the moment critical sections, and this is a conservative assumption if moment controls the load rating. In cases where shear appears to control the load rating, Chapter 9, Section C of this *Guide* provides additional information.

Capacity Step 7. Calculate the shear capacity using Equation 10 or if needed Equation 11.

Because shear usually does not control the load rating, AASHTO allows a simple, conservative calculation for the shear capacity using the minimum shear capacity shown in Equation 10. If the culvert load rating is not controlled by shear, the simpler calculation is adequate.

EQ 10. MINIMUM SHEAR CAPACITY (DERIVED FROM *SSHB* 8.16.6.7).

$\phi V_n = \phi 3bd\sqrt{f'_c}$ for single-span slabs cast monolithic with the culvert walls (typical for TxDOT designs).

$\phi V_n = \phi 2.5bd\sqrt{f'_c}$ for single-span slabs simply supported.

where:

ϕV_n	=	the shear capacity of the section (lb)
ϕ	=	0.85 from <i>SSHB</i> 16.6.4.6
f'_c	=	the compressive strength of concrete (psi)
d	=	the depth from compression face to tensile reinforcement in the direction of M_u (in.)
b	=	width of the compression face member (typically 12 inches)

If it turns out that the culvert load rating is controlled by shear, Equation 11 can be used to determine shear capacity in the critical section. Equation 11 will yield a more accurate, less conservative value for shear capacity but requires knowledge of the shear and moment demands at each section and is therefore tedious and time-consuming to apply.

EQ 11. SHEAR CAPACITY EQUATION (SSHB 8.16.6.7.1 EQ.8-59).

$$\phi V_n = \phi \left(2.14\sqrt{f'_c} + 4,600\rho \frac{V_u d}{M_u} \right) bd \leq 4bd\sqrt{f'_c}$$

where:	ϕV_n	=	the shear capacity of the section (lb)
		\geq	$3bd\sqrt{f'_c}$ for single-span slabs cast monolithic with the culvert walls
		\geq	$2.5bd\sqrt{f'_c}$ for single-span slabs simply supported
	ϕ	=	0.85 from SSHB 16.6.4.6
	f'_c	=	the compressive strength of concrete (psi)
	ρ	=	the tensile steel ratio in the direction of M_u
	d	=	the depth from compression face to tensile reinforcement in the direction of M_u (in.)
	b	=	width of the compression face member (typically 12 inches)
	V_u	=	the shear demand or load (kip)
	M_u	=	the moment demand or load (kli)
	$\frac{V_u d}{M_u}$	<	1.0

E. THRUST CAPACITY

Axial thrust capacity must be calculated at each critical section as defined in Figure 8. Technically these are the *moment* critical sections, but it is standard practice to also calculate axial thrust at these locations.

Capacity Step 8. Calculate the maximum thrust capacity using Equation 12. There is only one thrust capacity per critical section. This is a compressive (-) capacity.

EQ 12. THRUST CAPACITY (SSHB 8.16.4.2.1 EQ.8-31).

$$\phi P_n = -\phi [0.85f'_c(A_g - A_s - A'_s) + (A_s + A'_s)F_y]$$

where:	ϕP_n	=	the thrust capacity of the section (lb)
	f'_c	=	the compressive strength of concrete (psi)
	F_y	=	yield strength of the reinforcement (psi)
	A_g	=	the gross area of the section (in. ²)
	A_s	=	area of the tension reinforcement (in. ²)
	A'_s	=	area of the compression reinforcement (in. ²)

Usually the thrust demand is much smaller than the thrust capacity. In fact, the thrust demand is typically less than the incidental axial load assumed in the AASHTO *SSHB* for beam calculations. The capacity specifications in this Guide assume this to be the case.

A “thrust check” for each critical section is provided in the AASHTO *SSHB* and is described in Chapter 9, Section B of this *Guide* (next chapter). If the thrust check is satisfied then the thrust demand is less than the assumed incidental axial load and the culvert slab slices may be accurately modeled for both capacity and demand as beam elements. This is the normal situation.

However, if the thrust check is not satisfied, the slab slices are no longer considered beams for analysis purposes, but instead must be modeled as beam-columns. If this is the situation, combined bending equations must be used from AASHTO *SSHB* Section 8.16.4.3.

F. CULVLR 2.0 SOFTWARE – CULVERT CAPACITY CALCULATIONS

Culvert capacity, largely driven by policy, is a “behind the scenes” structural engineering task of the culvert load rating process. Here the load rating engineer uses the analytical model for a given culvert segment to systematically calculate capacities for each failure mode, at each critical section. CULVLR 2.0 performs this subtask as part of the Level 1 and Level 3 load rating task. The load rater is directed to the Help File accompanying the CULVLR 2.0 software for further information.

G. EXAMPLE PROBLEM – CULVERT CAPACITY CALCULATIONS

The appendixes to this *Guide* do not include direct worked examples for the capacity calculations. These calculations are performed incidental to Level 1 and Level 3 load rating.

9. LEVEL 1 (STRUCTURAL FRAME) ANALYTICAL MODEL

A. OVERVIEW

The *Culvert Rating Guide* presents a hierarchical approach to calculate the demand loads using different analytical models. The first level, Level 1, uses a two-dimensional, structural frame model. The next level, Level 3, uses a two-dimensional, finite element analysis model of the soil-structure system to determine demands. This *Guide* also discusses the general case for culvert modeling, which is a Level 4 analysis. Level 4 is the most sophisticated of the modeling approaches and uses a two or three-dimensional finite element model of the soil-structure system.

This chapter presents the Level 1 analysis, which is Task 5 of the culvert load rating process. Level 1 uses AASHTO loadings, balancing bottom slab loads, and simply-supported boundary conditions

B. GENERALIZED STEP-BY-STEP PROCEDURE FOR DETERMINING DEMAND LOADS

This chapter focuses on calculation of demand loads using analytical (computer) modeling for the Level 1 analysis approach. For this level of analysis, the following step-by-step procedure applies:

- Demand Step 1.** Obtain load rating parameters necessary to define each aspect of the computer model: dimensional data, strength properties for steel and concrete, soil properties, and loads (these are load rating tasks 1 through 4, previously described).
- Demand Step 2.** Create the analytical model by laying out the nodes and members and identifying the critical sections for the culvert.
- Demand Step 3.** Apply appropriate boundary conditions.
- Demand Step 4.** Calculate the magnitude of dead and live loads for both vertical and lateral stress distributions.
- Demand Step 5.** Apply the dead and live load stress distributions to the culvert model.
- Demand Step 6.** Define load cases for the model. Briefly stated, this consists of one set of load cases designed to induce maximum moment at the culvert haunches, and a second set of load cases designed to induce maximum moment at culvert mid-spans.
- Demand Step 7.** Perform demand calculations for each load case. That is, perform separate computer runs as necessary to define demand moments, shears and axial thrusts at each critical section as defined for each load case. Four computer runs, minimum, are typically required.
- Demand Step 8.** After determining the demands, use Equation 13 to check that actual thrust demand is lower than the incidental axial load assumed in the moment capacity equations.

EQ 13. THRUST CONTROL LIMIT (SSHB 8.16.4.3 EQ.8-37).

$$P_u \geq 0.1f'_c A_g$$

where: P_u = the thrust demand (lb)

f'_c = the compressive strength of concrete (psi)

A_g = the gross area of the section (in.²)

It is assumed throughout this *Guide* that Equation 13 will always be satisfied. However, if this check is not met, the capacities must be recalculated using beam-column theory as described in AASHTO *SSHB* section 8.16.4.3.

Demand Step 9. This step moves beyond calculation of the demand loads. Once the demand moments, shears and thrusts are established for each critical section in the culvert, for each load case, these must be combined with the corresponding capacity values to determine the rating factor for both inventory and operating conditions per Equation 1.

Demand Step 10. The controlling rating factor for each critical section is determined by selecting the minimum rating factor, for both inventory and operating conditions, based on the maximum and minimum values for each type of load (moment, shear and thrust) for each load case.

Demand Step 11. If shear controls the inventory and operating ratings, the load rater should perform a less-conservative analysis of the shear failure mode based on shear critical sections as per the provisions in Section C of this chapter.

Demand Step 12. The controlling rating factors for the culvert are the minimum rating factors for both inventory and operating conditions.

The following sections of this chapter provide details of this step-by-step procedure, as it applies to each level of analysis.

C. SHEAR FAILURE MODE ANALYSIS

Discussions about culvert load rating commonly acknowledge that in most cases, the mode of failure that controls the load rating is moment. The one exception is deep fill culverts which tend to fail in shear. Results from a parametric analysis of a representative sample of TxDOT's reinforced concrete box culvert designs support these points.

Because culvert load ratings are usually controlled by moment, it makes sense to perform initial load rating analyses for all failure modes (moment, axial thrust and shear) based on moment critical sections. These analyses will be technically accurate both for moment and axial demands, and conservative for shear.

The reason for this conservatism is that the shear critical section for culvert corners is actually located at a distance d away from the wall face consistent with AASHTO *SSHB* 8.8.2 and 8.16.6.1.2 (see Figure 25a), rather than located at the wall face as is done for moment (see Figure 8a). This distinction only applies to culverts without haunches, which is the most common case for TxDOT. For culverts with haunches, the corner critical sections for shear are a distance d from the middle of the haunch (Figure 25b). Mid-span critical section locations for moment and shear are the same.

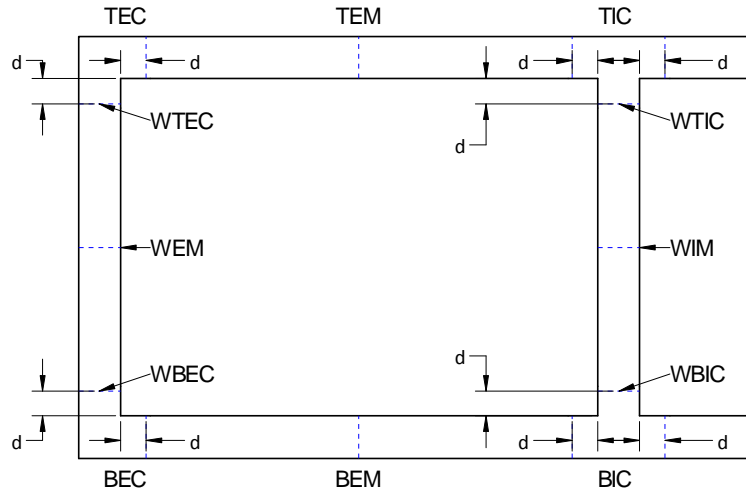

FIG 25a. Shear Critical Sections For Culverts without Haunches.

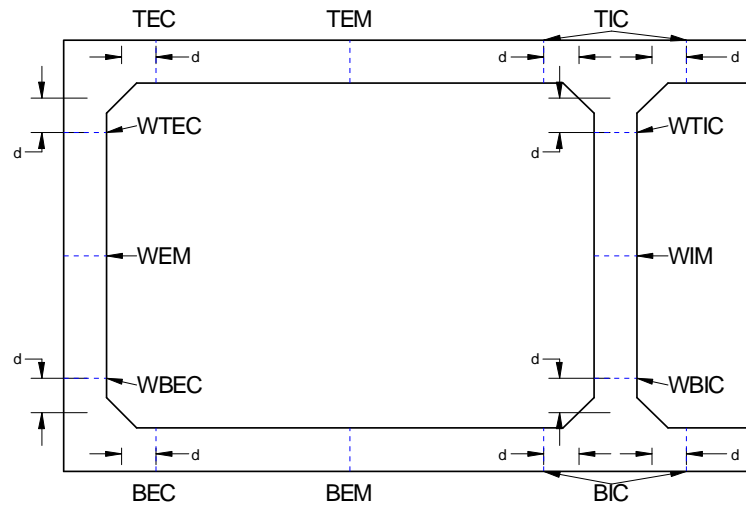

FIG 25b. Shear Critical Sections for Culverts with Haunches.

Only in cases where shear ends up controlling the load rating would it be necessary to reanalyze shear demands based on the *shear* critical sections of Figure 25. The following steps capture this procedure.

- Shear Provision 1.** Assume that the controlling failure mode for the load rating is *moment*. Use the moment critical sections (see Figure 8) as discussed in this *Guide*. Perform load rating analyses and check all failure modes (moment, axial thrust and shear).
- Shear Provision 2.** If *moment* controls the load rating, there is no need to further refine the shear demand or capacity analyses.
- Shear Provision 3.** If *shear* controls the load rating, and the inventory rating is greater than or equal to HS-20 (inventory rating factor (IRF) ≥ 1), the culvert will not require load posting and there is no need to further refine the shear demand or capacity analyses.

Shear Provision 4. If *shear* controls the load rating, and the inventory rating is less than HS-20 ($IRF < 1$), redo the shear analyses based on the shear critical sections as defined in AASHTO *SSHB* 8.8.2 and 8.16.6.1.2, with the critical section located at a distance d away from the point of support (see Figure 25). Moment and axial demands are unchanged. Select the new lowest rating factors from all failure modes.

Shear Provision 5. If, based on the revised shear analysis, *shear* continues to control the load rating and the inventory rating is still less than HS-20 ($IRF < 1$), use the demand-dependent shear capacity equation (Equation 11) to generate capacity values used to calculate rating factors. This approach does not include any of the conservative shear assumptions. Select the new lowest rating factors from all failure modes.

D. LEVEL 1 ANALYSIS: TWO-DIMENSIONAL, SIMPLY-SUPPORTED STRUCTURAL FRAME MODEL

This level of analysis uses a relatively simple two-dimensional frame analysis model and AASHTO loading parameters. It is designed to provide a quick, conservative, repeatable load rating.

1. ASSUMPTIONS

The following assumptions are made in the two-dimensional structural frame analysis stage:

- AASHTO loads are applied.
- Gross section properties control structure behavior at ultimate strength.
- Culvert corners are considered rigid.
- Supporting soil pressures are uniform over the length of the bottom slab.
- All assumptions inherently involved in two-dimensional, frame analysis.
 - Reinforced concrete behaves elastically with stress related linearly to strain.
 - Reinforced concrete behaves identically regardless of direction of the applied load.
 - All deformations are small.
 - Beams are long relative to their depth.
 - Plane sections remain plane.
- A one foot ($b = 12$ in.) section of the culvert may be analyzed as a frame.
- No hydrostatic pressure (water) exists inside the culvert.
- Supporting soils are fully drained, i.e. no hydrostatic pressure outside the culvert.
- Moments resulting in tension on the inside face of the culvert are positive.
- Moments resulting in tension on the outside face of the culvert are negative.

Though reinforced concrete does not generally satisfy the first two, two-dimensional, frame analysis assumptions – namely, elasticity and homogeneity – this model will predict approximate and conservative moment, shear and thrust demands.

2. MODEL DIMENSIONS

The Level 1 model should be developed so that beam nodes are at the centerline of the slab sections they are modeling. Each section should use the gross area properties of a one-foot wide strip of culvert.

A node should be placed at each critical section so that the resultant forces and moments will be calculated automatically at those points. The location of the corner critical sections can be determined directly as illustrated in Figure 26. As noted earlier, AASHTO specifies that the mid-span critical sections must be determined by locating the maximum combined (dead and live load) moment in the mid-span region. However, for the purposes of this *Guide*, the mid-span critical section is always assumed to be located at mid-span.

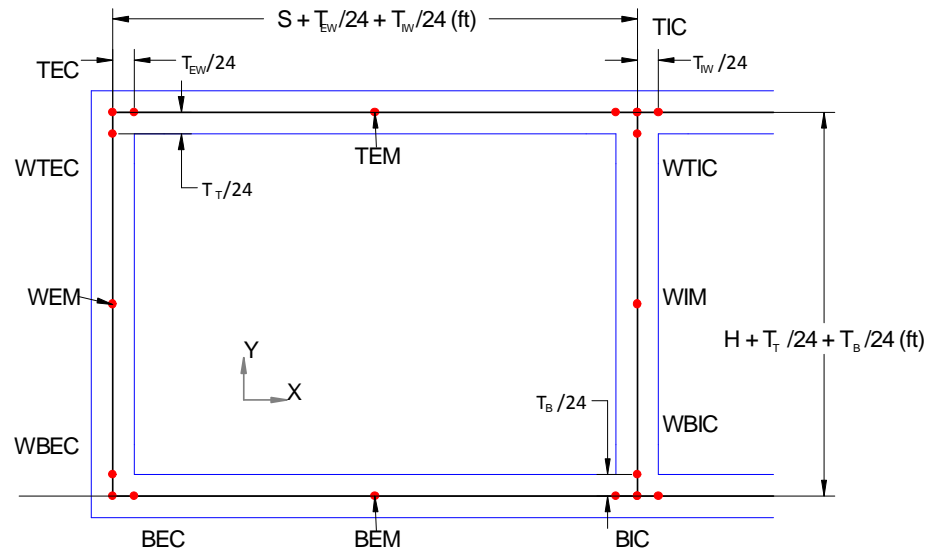

FIG 26a. Model Dimensions for a Level 1 Analysis for Culverts without Haunches.

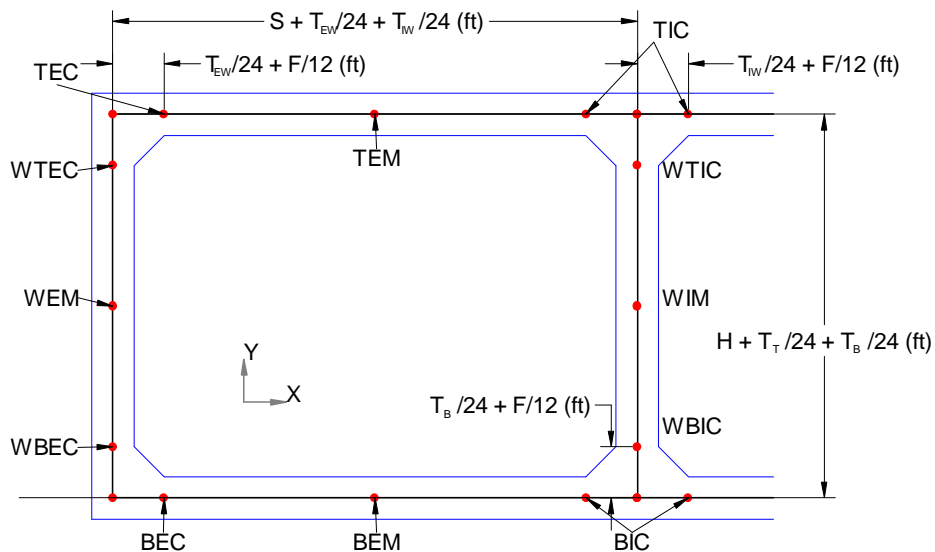

FIG 26B. Model Dimensions for a Level 1 Analysis for Culverts with Haunches.

3. BOUNDARY CONDITIONS

In the Level 1 model, the primary function of the boundary conditions is to maintain global stability. Reactions are of no concern. The model should be simply supported, with a pin at the bottom left corner (restrain in global X and Y directions) and rollers at other bottom wall centerlines (restrain in global Y direction only). See Figure 27.

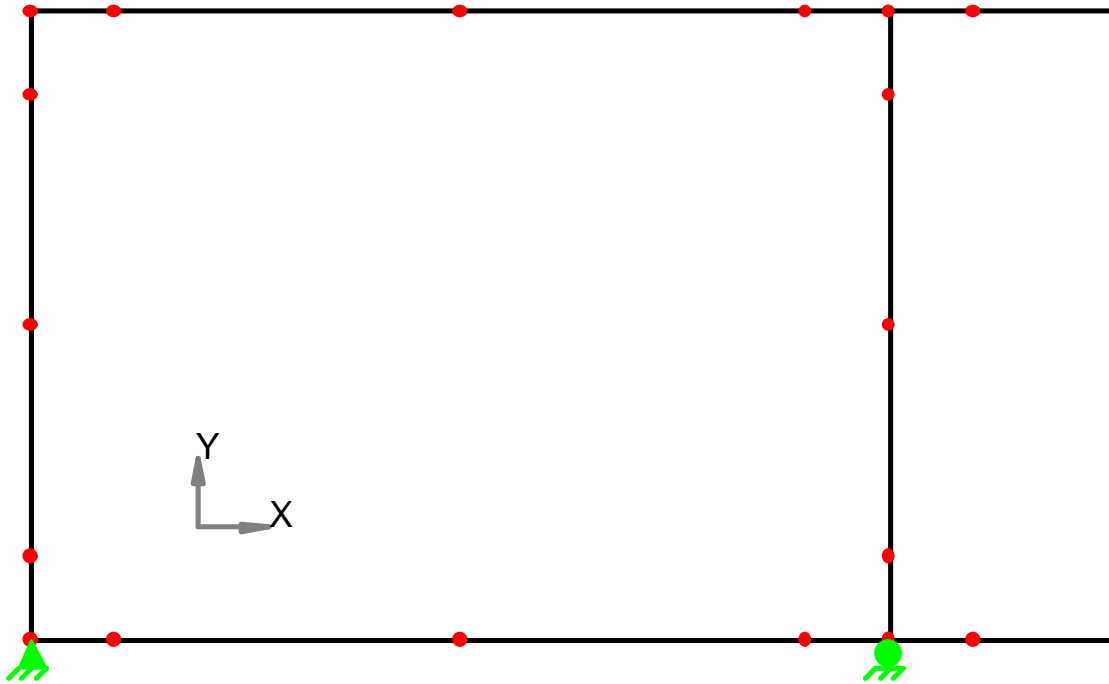

FIG 27. Boundary Conditions for Two Dimensional, Simply-Supported Structural Frame Model.

4. LOADS

The loads placed on the structure for Level 1 modeling correspond directly to the provisions of the AASHTO policy. Figure 28 shows the load location and direction conventions. The loads are as follows:

- DL_V ... Vertical Dead Load
- DL_{hT} ... Horizontal Dead Load, top of culvert
- DL_{hB} ... Horizontal Dead Load, bottom of culvert
- LL_{VT} ... Vertical Live Load, top slab
- LL_{VB} ... Vertical Live Load, bottom slab
- LL_h ... Horizontal Live Load
- SW ... Self Weight of the culvert

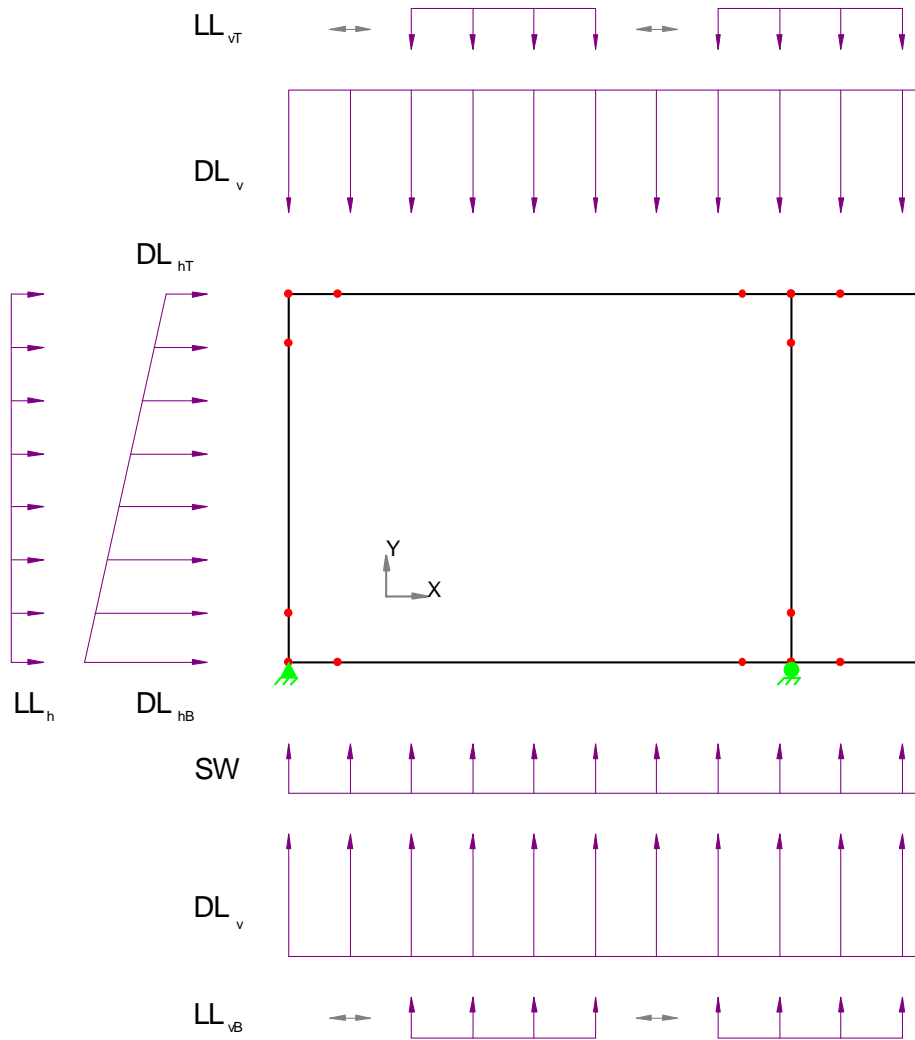

FIG 28. Load Conventions for Two Dimensional, Simply-Supported Structural Frame Model.

A unique aspect of the Level 1 model is that in order to account for upward soil pressure support, whatever load is placed downward on the structure should also be placed upward on the bottom slab, uniformly. The result is balanced vertical loading and no reactions in the supports. The boundary conditions only keep the model stable. They should not contribute significantly to the support of the structure.

d. DEAD LOAD

Per Equation 14, the first load represents the weight of the soil on top of the structure. According to AASHTO *SSHB* 6.2.1.B, the unit weight of soil is 120 pcf. This load must be placed downward on the top slab, and balanced by placing it upward on the bottom slab.

EQ 14. VERTICAL DEAD LOAD, DL_v (KSF)

$$DL_v = \text{cover soil} = (0.120 \text{ kcf}) D$$

where: DL_v = the vertical dead load (ksf)

D = cover soil depth (ft)

Per Equation 15, the second load represents the self-weight of the structure. If the chosen analysis tool has a gravity feature, this should be used to accurately distribute the self-weight across the structure. Otherwise, the weight of the slabs and walls should be applied manually in the downward direction, expressed in terms of a uniformly distributed load. Whether the self-weight is applied automatically or manually, the total self-weight of the culvert should also be applied upward across the bottom slab, expressed in terms of a uniformly distributed load.

EQ 15. SELF-WEIGHT OF THE CULVERT, SW (KSF)

$$SW = \left\{ (T_T + T_B) * \left[S + \frac{2 * T_{EW}}{12} + (N - 1) \frac{T_{IW}}{12} \right] + 2 * T_{EW} * H + (N - 1) * T_{IW} * H \right\} \frac{0.150 \text{ kcf}}{S * 12}$$

where: SW = the vertical dead load (ksf)

T_T = top slab thickness (in.)

T_B = bottom slab thickness (in.)

T_{IW} = interior wall thickness (in.)

T_{EW} = exterior wall thickness (in.)

S = the clear span of a single box (ft)

H = the clear height of a single box (ft)

N = the number of box spans

The third load is the horizontal dead load. This dead load is a trapezoidal load placed on the outside walls of the culvert facing inward. The load is determined using the equivalent fluid weight of soil listed in AASHTO *SSHB* 6.2.1.B and 3.20.2. Equation 16 and Equation 17 define the horizontal load at the top and bottom of the slab. In these equations, the D and H values are in feet, and the T values are in inches. Intermediate points may be determined by linear interpolation as necessary.

EQ 16. HORIZONTAL DEAD LOAD AT THE TOP APPLIED TO THE EXTERIOR WALLS OF THE CULVERT, DL_{hT} (KSF)

$$DL_{hT} = \text{full lateral pressure} = (0.060 \text{ kcf}) \left(D + \frac{T_T}{24} \right)$$

where: DL_{hT} = the horizontal dead load at the top of the exterior walls (ksf)

T_T = top slab thickness (in.)

D = cover soil depth (ft)

EQ 17. HORIZONTAL DEAD LOAD AT THE BOTTOM APPLIED TO THE EXTERIOR WALLS OF THE CULVERT, DL_{hB} (KSF)

$$DL_{hB} = \text{full lateral pressure} = (0.060 \text{ kcf}) \left(D + H + \frac{T_T}{12} + \frac{T_B}{24} \right)$$

where: DL_{hB} = the horizontal dead load at the bottom of the exterior walls (ksf)

T_T = top slab thickness (in.)

T_B = bottom slab thickness (in.)

H = the clear height of a single box (ft)

D = cover soil depth (ft)

e. LIVE LOAD

The live load on the structure as required by AASHTO *SSHB* 3.7.6 is an HS-20 truck. There are three live loads due to the HS-20 truck: (1) the horizontal live load, LL_h ; (2) the vertical live load applied to the top slab, LL_{vT} ; and (3) the vertical live load applied to the bottom slab, LL_{vB} . The impact factor, IM , and all other variables used in the live load equations are defined in Table 1.

Per Equation 18, the first live load is the horizontal live load, LL_h (ksf). This load is constant regardless of the number of trucks passing over the culvert. AASHTO *SSHB* 3.20.3 provides a 2 ft surcharge allowance for trucks which are approaching, but not directly above, the culvert.

EQ 18. HORIZONTAL LIVE LOAD APPLIED TO THE EXTERIOR WALLS, LL_H (KSF)

$$LL_h = 2' * (.060 \text{ kcf}) = .120 \text{ ksf}$$

where: LL_h = the horizontal live load on the exterior walls (ksf)

The vertical live load applied to the top of the culvert, LL_{vT} (ksf), is the second type of live load. The magnitude of the vertical live load depends on the depth of fill, the wheel load, the culvert span, the impact factor, the number of lanes, and the number of trucks. For this *Guide*, the vertical live load has been expressed in terms of 15 distinct equations derived from AASHTO *SSHB* 3.7.6, 3.12.1, 3.24.3.2 and 6.4, including the lane reduction factor described in AASHTO *SSHB* 3.12.1. These 15 equations are collectively designated as Equation 19.

For a given culvert, the load rater must select one of the 15 equations to determine the magnitude of the vertical live load. Two variables govern selection of the appropriate live load equation. The first is the number of lanes passing over the culvert. Section 3.6 of the *SSHB* provides guidance for determining traffic lanes. Generally, the number of lanes is determined by the number of whole, 12-

foot-wide lanes that will fit across the roadway. Roadways between 20' and 24' will have two lanes. The second variable is the depth of fill, D . This fill depth will yield the proper load configuration as per the AASHTO stress distribution. Taken together, the number of lanes and the fill depth establish the controlling number of trucks and identify the proper equation to use for LL_{VT} .

Once the magnitude of the live load has been established, it is necessary to define the area over which the live load acts. The vertical live load should be applied as a moving load across the top of the culvert structure. This will have the effect of creating a moment envelope, with both maximum and minimum values. The length over which the pressure should be applied, the center-to-center spacing for the distributed loads, and the wheel load, P , used to calculate each load are illustrated in Figure 29, Figure 30 and Figure 31 for different cover depths.

The final live load is the vertical live load applied upward to the bottom slab, LL_{VB} (ksf). This live load is derived from AASHTO *SSHB* 16.6.4.3. For this *Guide*, the magnitude of the upward live load has been expressed in terms of 15 distinct equations. These 15 equations are collectively designated as Equation 20. The load is placed upward on the bottom slab to balance the vertical live load on the top slab as illustrated in Figure 29, Figure 30 and Figure 31. Again, the load rater must select one of the 15 equations. The selected equation should correspond to the culvert's fill height and number of lanes.

EQ 19. VERTICAL LIVE LOAD APPLIED TO THE TOP SLAB, LL_{vT} (ksf).

No of Traffic Lanes	Depth of Fill, D (ft)	Magnitude, LL_{vT} (ksf)	Controlling No. of Trucks
1	$0 < D < 2'$	$LL_{vT} = \frac{(1 + IM) * P}{4 + 0.06 * S}$	1 truck
1	$2' < D < 3.4'$	$LL_{vT} = \frac{(1 + IM) * P}{(1.75 * D)^2}$	1 truck
1	$3.4' < D < 8'$	$LL_{vT} = \frac{2 * P}{1.75 * D * (1.75 * D + 6')}$	1 truck
1	$8' < D$	$LL_{vT} = \frac{4.5 * P}{(1.75 * D + 28') * (1.75 * D + 6')}$	1 truck
2	$0 < D < 2'$	$LL_{vT} = \frac{(1 + IM) * P}{4 + 0.06 * S}$	1 truck
2	$2' < D < 2.3'$	$LL_{vT} = \frac{(1 + IM) * P}{(1.75 * D)^2}$	1 truck
2	$2.3' < D < 3.4'$	$LL_{vT} = \frac{(1 + IM) * 2 * P}{1.75 * D * (1.75 * D + 4')}$	2 trucks
2	$3.4' < D < 8'$	$LL_{vT} = \frac{4 * P}{1.75 * D * (1.75 * D + 16')}$	2 trucks
2	$8' < D$	$LL_{vT} = \frac{9 * P}{(1.75 * D + 28') * (1.75 * D + 16')}$	2 trucks
3+	$0 < D < 2'$	$LL_{vT} = \frac{(1 + IM) * P}{4 + 0.06 * S}$	1 truck
3+	$2' < D < 2.3'$	$LL_{vT} = \frac{(1 + IM) * P}{(1.75 * D)^2}$	1 truck
3+	$2.3' < D < 3.4'$	$LL_{vT} = \frac{(1 + IM) * 2 * P}{1.75 * D * (1.75 * D + 4')}$	2 trucks
3+	$3.4' < D < 7.2'$	$LL_{vT} = \frac{4 * P}{1.75 * D * (1.75 * D + 16')}$	2 trucks
3+	$7.2' < D < 8'$	$LL_{vT} = \frac{6 * .9 * P}{1.75 * D * (1.75 * D + 26')}$	3 trucks
3+	$8' < D$	$LL_{vT} = \frac{13.5 * .9 * P}{(1.75 * D + 28') * (1.75 * D + 26')}$	3 trucks

where: LL_{vT} = the vertical live load on the top slab (ksf)

IM = the impact factor from Table 1

S = the clear span of a single box (ft)

P = either 4 or 16 kips as indicated in Figure 29 through Figure 31

D = cover soil depth (ft)

EQ 20. VERTICAL LIVE LOAD APPLIED TO THE BOTTOM SLAB, LL_{vB} (ksf)

No. of Traffic Lanes	Depth of Fill, D (ft)	Magnitude, LL_{vB} (ksf)	Controlling No. of Trucks
1	$0 < D < 2'$	$LL_{vB} = \frac{(1 + IM) * P}{2 * H * (4 + 0.06 * S)}$	1 truck
1	$2' < D < 3.4'$	$LL_{vB} = \frac{(1 + IM) * P}{1.75 * D * (1.75 * D + 2 * H)}$	1 truck
1	$3.4' < D < 8'$	$LL_{vB} = \frac{2 * P}{(1.75 * D) * (1.75 * D + 6' + 2 * H)}$	1 truck
1	$8' < D$	$LL_{vB} = \frac{4.5 * P}{(1.75 * D + 28') * (1.75 * D + 6' + 2 * H)}$	1 truck
2	$0 < D < 2'$	$LL_{vB} = \frac{(1 + IM) * P}{2 * H * (4 + 0.06 * S)}$	1 truck
2	$2' < D < 2.3'$	$LL_{vB} = \frac{(1 + IM) * P}{1.75 * D * (1.75 * D + 2 * H)}$	1 truck
2	$2.3' < D < 3.4'$	$LL_{vB} = \frac{(1 + IM) * 2 * P}{(1.75 * D) * (1.75 * D + 4' + 2 * H)}$	2 trucks
2	$3.4' < D < 8'$	$LL_{vB} = \frac{4 * P}{(1.75 * D) * (1.75 * D + 16' + 2 * H)}$	2 trucks
2	$8' < D$	$LL_{vB} = \frac{9 * P}{(1.75 * D + 28') * (1.75 * D + 16' + 2 * H)}$	2 trucks
3+	$0 < D < 2'$	$LL_{vB} = \frac{(1 + IM) * P}{2 * H * (4 + 0.06 * S)}$	1 truck
3+	$2.1' < D < 2.3'$	$LL_{vB} = \frac{(1 + IM) * P}{1.75 * D * (1.75 * D + 2 * H)}$	1 truck
3+	$2.3' < D < 3.4'$	$LL_{vB} = \frac{(1 + IM) * 2 * P}{(1.75 * D) * (1.75 * D + 4' + 2 * H)}$	2 trucks
3+	$3.4' < D < 7.2'$	$LL_{vB} = \frac{4 * P}{(1.75 * D) * (1.75 * D + 16' + 2 * H)}$	2 trucks
3+	$7.2' < D < 8'$	$LL_{vB} = \frac{6 * .9 * P}{(1.75 * D) * (1.75 * D + 26' + 2 * H)}$	3 trucks
3+	$8' < D$	$LL_{vB} = \frac{13.5 * .9 * P}{(1.75 * D + 28') * (1.75 * D + 26' + 2 * H)}$	3 trucks

where: LL_{vB} = the vertical live load on the bottom slab (ksf)

IM = the impact factor from Table 1

S = the clear span of a single box (ft)

H = the clear height of a single box (ft)

P = either 4 or 16 kips as indicated in Figure 29 through Figure 31

D = cover soil depth (ft)

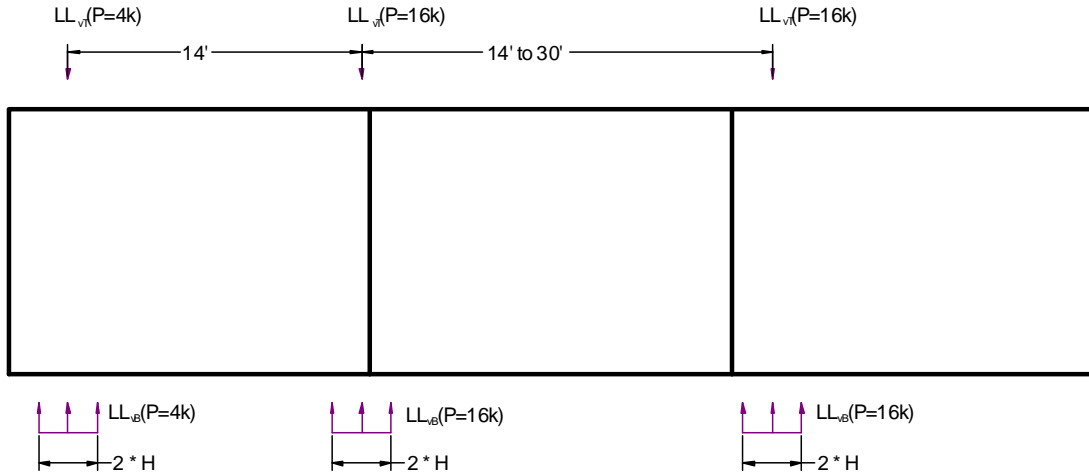

FIG 29. Live Load Distribution for $D < 2'$ for 2D, Simply-Supported Structural Frame Analysis.

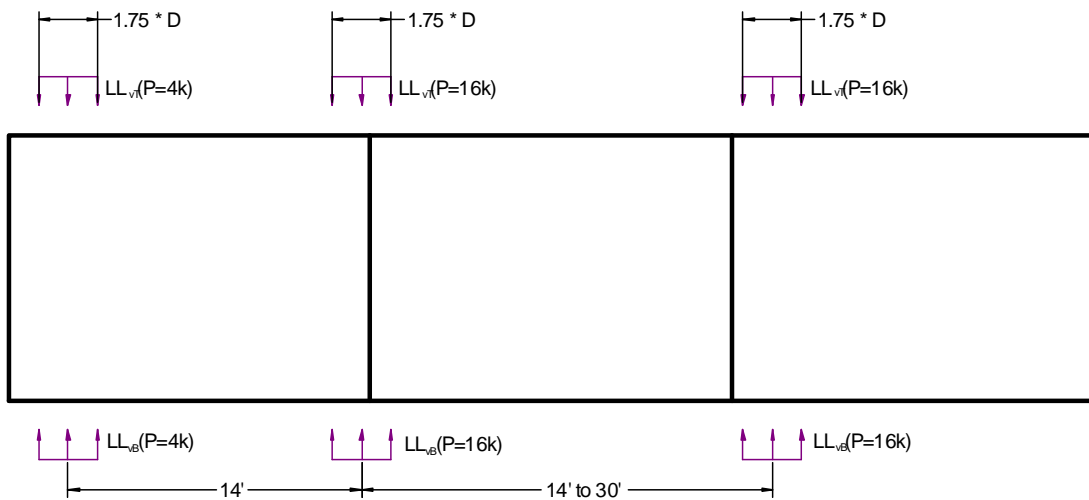

FIG 30. Live Load Distribution for $2' < D < 8'$ for 2D, Simply-Supported Structural Frame Analysis.

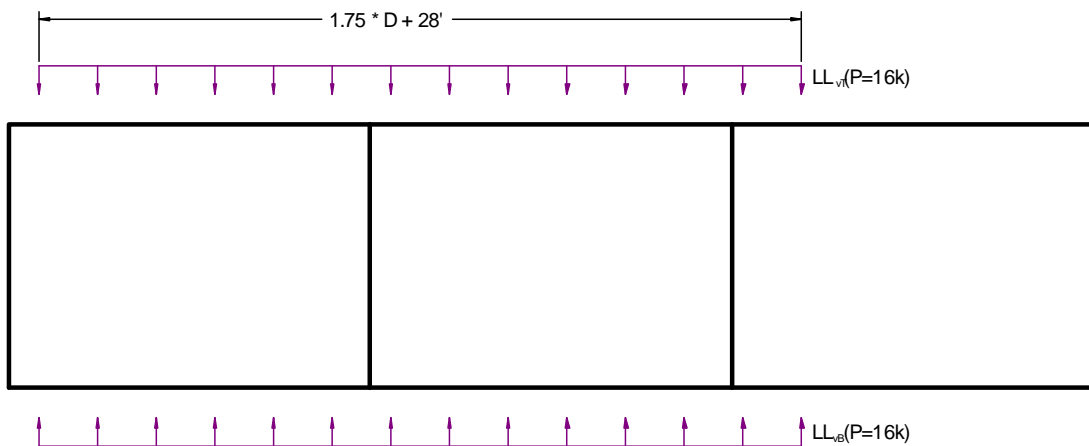

FIG 31. Live Load Distribution for $D > 8'$ for 2D, Simply-Supported Structural Frame Analysis.

5. LOAD CASES

In accordance with AASHTO *SSHB* 3.20.2, two demand analyses must be made to determine the worst case loading conditions on the culvert structure. The two analyses combine the basic loadings differently to produce conservative demand moments, shears and thrusts.

a. TOTAL LOAD CASE

The first analysis is the “total load case.” The total load case is designed to create the maximum demand in most of the culvert structure; that is, critical sections TEC, TIC, BIC, BEC, WIM, WEM, WTIC, WBIC, WBEC, WTEC as per Figure 6. The total load case is designed to yield the maximum shear and axial demands in the whole culvert and the maximum moment demands in all but the top and bottom mid-spans (TEM, TIM, BEM and BIM). This load case applies the above-described loads with a load factor of 1.

b. REDUCED LATERAL LOAD CASE

The second analysis is the “reduced lateral load case” as described in AASHTO *SSHB* 6.2.1.B, 3.20.2. The reduced lateral load case is designed to create the maximum demand moment for the positive moment sections (TEM, TIM, BEM, BIM). See Figure 8. This load case is intended to create a worst case scenario for the slab moments by reducing the amount of reverse curvature created by lateral pressure on the culvert walls. The reduced lateral load case uses the following load factors:

- Vertical dead load applied to top slab is the same as Equation 14. Load factor of 1.
- The self-weight of the culvert is the same as Equation 15. Load factor of 1.
- Horizontal dead load at the top applied to the exterior walls of the culvert is one-half the value calculated by Equation 16. Load factor of 0.5.
- Horizontal dead load at the bottom applied to the exterior walls of the culvert is one-half the value calculated by Equation 17. Load factor of 0.5.
- No horizontal live load is applied to the exterior walls of the culvert per Equation 18. Load factor of 0.
- Vertical live load applied to the top slab is the same as Equation 19. Load factor of 1.
- Vertical live load applied upward to the bottom slab is the same as Equation 20. Load factor of 1.

c. INTERPRETATION OF LOAD CASE DATA

As a general rule, it is necessary to perform multiple computer runs (at least two) to calculate moment, shear and thrust demands for each load case. Once the data are obtained, it is customary practice to interpret the data holistically. That is, the load rater should evaluate the maximum and minimum moments, shears and thrusts for each critical section, treating the two load cases independently.

Stated another way, even though the two load cases are designed with the intent to achieve maximum demands at either the corners or the mid-spans, the load rater should not make an *a priori* decision to only evaluate the data this way. This means that the load rater should look at more than just the corner critical sections for the total load case results, and more than just the mid-span critical sections for the reduced lateral load case results. Instead, the load rater should evaluate moment, shear and thrust demands for all of the critical sections for each load case.

6. DEMAND LOAD CALCULATIONS

Having created the analytical model, defined the boundary conditions, determined the magnitude and extent of loads, and specified the load cases, the next step is to calculate the moment, shear and thrust demands. This requires application of an appropriate structural analysis software package, as discussed in the following section of the *Guide*.

7. ANALYTICAL PROGRAM – CULV-5

a. OVERVIEW

The two-dimensional, simply-supported frame model (Level 1) can be analyzed using several commercially-available structural analysis software programs. Examples include RISA-2D, BRASS, BOXCAR, CULV-5 (TxDOT's program) or older frame analysis programs.

At TxDOT, the program most adept for Level 1 calculations is CULV-5. Therefore, specific guidance will be provided for this tool. If a user is more comfortable with another frame analysis program, the designer is free to use it.

CULV-5 is an MS-DOS program developed and distributed by the Texas Department of Transportation. The heart of the program is a two-dimensional frame analysis. Documentation supporting CULV-5 includes the Version 1.71 Readme file (TxDOT, 2004), Input Guide (TxDOT, 2003), and CULV5 – Concrete Box Analysis Program (TxDOT, 2003). The load rater who intends to use CULV-5 should become familiar with this documentation to better understand the input, analysis approach, and program output.

b. CULV-5 STRENGTHS AND LIMITATIONS

The CULV-5 program has some notable strengths that make it the ideal first choice for a Level 1 culvert load rating program. These are:

- Quick and conservative
- Program inputs are very simple
- Appropriate live and dead loads are automatically calculated and applied
- Influence lines are used to determine maximum moments, shears and thrust
- A more conservative bottom slab live load is used
- The sign convention used is the same as the sign convention outlined in Chapter 8, Section B

Notwithstanding its many strengths, the CULV-5 program also has some notable limitations that must be recognized and addressed:

- Demand at the critical corner sections is not automatically calculated.
- The use of influence lines to calculate live load moments results in an overly conservative live load applied to the bottom of the structure.
- Only culverts with 4 or fewer barrels may be analyzed directly. Culverts with more than 4 barrels may be approximated using a 4 barrel model at the expense of slightly more conservative results.

The limitations may be overcome. Determining the critical section demand requires linear interpolation between the 10th point demands which the program does produce. If the culvert fails to rate, not much time has been spent and the user may move on to the higher-level models.

c. CULV-5 STEP-BY-STEP INSTRUCTIONS

Culvert load rating for Level 1 using the CULV-5 program can be accomplished by following these steps. This sequence assumes the load-rater has already defined the input parameters and is prepared to create the Culv-5 input file.

CULV5 Step 1. Using data obtained for the culvert as discussed in Chapters 6 and 7 of this *Guide*, write the CULV-5 input file in a basic text editor (*e.g.*, Notepad) according to the form in Figure 32. Alternatively, the load rater may use the “Culv5 Input” program developed by TechMRT and hosted on the TxDOT Bridge Division website to create the input file.

CULV5 Step 2. Run the CULV-5 program using the input file created in Step 1. One of the positive features of CULV-5 is that it is heavily preprogrammed. For culvert rating, this means that all calculations can be made based on output from running the CULV-5 program only one time.

CULV5 Step 3. Interpretation of the CULV-5 output requires establishing both corner and mid-span critical sections.

- a. Using Figure 33 select the 10th points to set up the linear interpolation associated with the corner critical sections.



FIG 32. CULV-5 INPUT FORMAT.

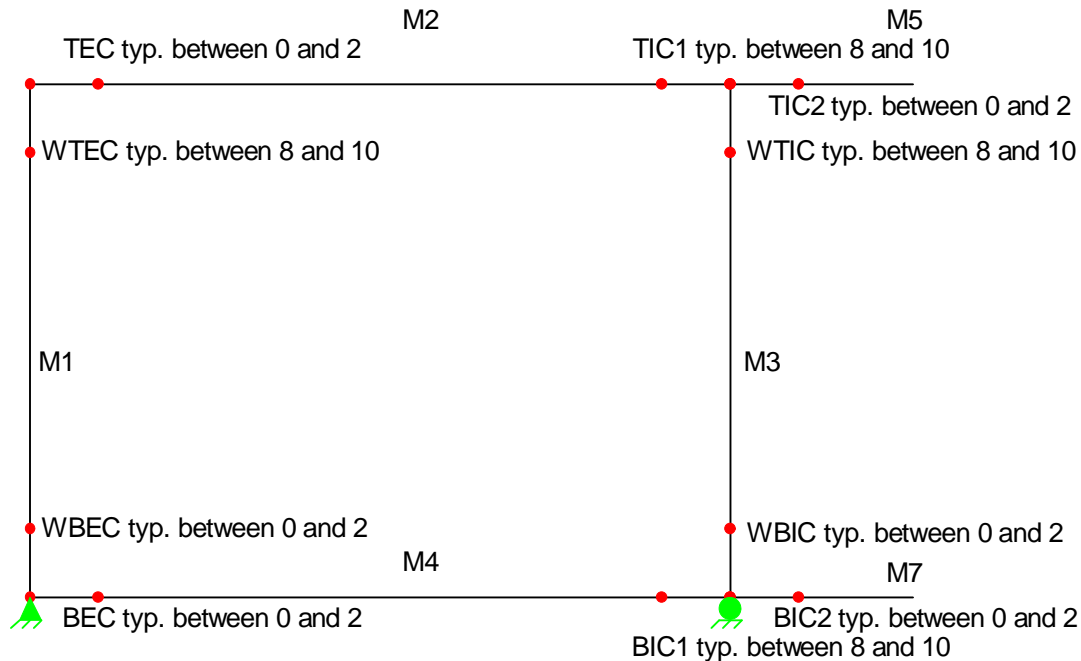

FIG 33. CULV-5 Member and Critical Section Design.

With reference to Figure 33, linear interpolation to establish the corner critical sections must work from the corner to the nearest corner critical section. For example, the upper right corner section, TIC1, for member 2 (M2) might be located between nodes 8 and 9. In this example, the calculation would start with the demands at node 9 and add the fraction between nodes 9 and 8.

- b. Critical sections for mid-span demands (TEM, TIM, BEM, BIM, WEM and WIM) do not require interpolation. These may be selected at mid-span (node 5).

CULV5 Step 4. From the CULV-5 output file, select the **SUMMARY OF INDIVIDUAL UNFACTORED MOMENTS, SHEAR AND AXIAL FORCES** tables. Record the vertical dead load (VDL), lateral dead load (LDL), maximum vertical live load (+VLL), minimum vertical live load (-VLL), and lateral live load (LLL) demands at each critical section.

CULV5 Step 5. Calculate the dead and live load demand for each demand type (moment, shear and axial), for each load case at each critical section using Equation 21 and Equation 22. D is the dead load demand and L is the live load demand required for rating in Equation 1. Note that the live load demands will have a maximum and minimum because these derive from a moving load which produces an “envelope” type solution. To maintain a systematic approach, typical practice is to determine both the maximum and minimum live loads for each type of demand at each critical section and to select the minimum (controlling) value when calculating rating factors.

EQ 21. TOTAL LOAD CASE.

$$D = VDL + LDL$$

$$L = VLL + LLL$$

where: D = the dead load demand
 L = the live load demand
 VDL = the vertical dead load demand from CULV5 output
 LDL = the lateral dead load demand from CULV5 output
 VLL = the vertical live load demand from CULV5 output. (Load rating calculations for this variable must be done twice, for the maximum and minimum values.)
 LLL = the lateral live load demand from CULV5 output

EQ 22. REDUCED LATERAL LOAD CASE.

$$D = VDL + \frac{1}{2}LDL$$

$$L = VLL$$

where: D = the dead load demand
 L = the live load demand
 VDL = the vertical dead load demand from CULV5 output
 LDL = the lateral dead load demand from CULV5 output
 VLL = the vertical live load demand from CULV5 output. (Load rating calculations for this variable must be done twice, for the maximum and minimum values.)

CULV5 Step 6. Use Equation 13 to verify that actual thrust demand is lower than the incidental axial load assumed in the moment capacity equations.

CULV5 Step 7. This step goes beyond calculation of demand loads and has to do with calculating the culvert load rating. Proceed to calculate Inventory and Operating rating factors for each critical section, for each demand type, for each load case per Equation 1.

When calculating the rating factors, exercise extreme care regarding the signs for both demands and capacities.

- Live load and capacity must be in the same sign and direction.
- If the live load and dead load are in opposite directions or the calculated rating factor is negative, a check should be made to insure that the structure has adequate capacity to support the dead load. i.e. $C \geq 1.3D$

CULV5 Step 8. Select the controlling inventory and operating rating factors for each section.

CULV5 Step 9. Select the overall controlling rating factors for the culvert.

CULV5 Step 10. If shear controls the load rating, the load rater should perform a less-conservative analysis of the shear failure mode based on shear critical sections as per the provisions in Chapter 9, Section C.

CULV5 Step 11. Calculate the Inventory and Operating Ratings per Equation 2.

E. CULVLR 2.0 SOFTWARE – LEVEL 1 ANALYTICAL MODEL

Level 1 load rating represents a culminating structural engineering task of the culvert load rating process. Here the load rating engineer uses the analytical model for a culvert segment to systematically calculate capacities, demands, and rating factors at each critical section. CULVLR 2.0 performs this subtask as part of the Level 1 load rating task. The load rater is directed to the Help File accompanying the CULVLR 2.0 software for further information.

F. EXAMPLE PROBLEM – LEVEL 1 ANALYTICAL MODEL

Appendix E of this *Guide* includes a worked examples for the Level 1 load rating calculations using CULV-5 for the demand model.

G. REPORTING LEVEL 1 LOAD RATING RESULTS

Upon completion of the Level 1 analysis, the load rater will want to report the load rating results which is the seventh and final task of the load rating process. The culvert rating program, CULVLR 2.0, allows descriptive input about the culvert structure as a means to provide context for all segment level load rating data.

However, individual culvert load rating reports for Level 1 analysis are reported at the culvert segment level. CULVLR 2.0 offers various reporting options. The load rater may publish a Level 1 summary report, the summary plus input, or a comprehensive report for the segment. The comprehensive report includes not only the input but also the capacities, the moment, shear and thrust demands, and the rating factors for all critical sections of the culvert segment.

Appendix F of this *Guide* includes a worked example for reporting the results of Level 1 load rating calculations.

10. LEVEL 3 (SOIL-STRUCTURE INTERACTION) ANALYTICAL MODEL

A. OVERVIEW

Level 3 load rating is Task 6 of the culvert load rating process. Level 3 relies on a production-simplified, 2D, finite element model that accounts for soil-structure interaction. The updated Level 3 model used in this *Guide* accounts for differentiated soil loads, the influence of pavement, and a host of other variables.

The Level 3 analysis is based on a two-dimensional finite element model of the soil-structure system, and AASHTO vehicle loading parameters. The significant benefit of this model is that it evaluates the *interaction* between the culvert structure and the surrounding soil. Soil is no longer just a load applied to the structural frame (culvert), but instead is an integral aspect of the load resistance portion of the model. Because traffic loads are applied directly to the overlying soil (pavement) and are transmitted through the soil elements to impact the culvert, this finite element approach obviates the need to use AASHTO assumptions for soil pressure distributions or live load distributions in the direction of traffic.

The defining feature of the Level 3 analysis is that it assumes both the soil and the culvert slab elements behave as *isotropic, linear-elastic materials*. That is, the dominant property for expressing the engineering behavior of these materials is their elastic modulus. This is obviously a simplified view for such complex materials, and other, more sophisticated constitutive models for both the culvert structure and the soil exist. However, for basic load rating analyses where actual material properties are usually not known, the uncertainty introduced by using a simplified linear elastic model for the culvert and soil is consistent with other uncertainties in the modeling process.

The basic sequence for Level 3 load rating is as follows:

1. Use the input features of TxDOT's CULVLR 2.0 program to create the two-dimensional model for the culvert segment.
2. From CULVLR, interface with RISA-3D (RISA Technologies 2012) to create the RISA soil-structural model. CULVLR auto-generates the RISA model from input data with the exception of the moving load pattern for live load. This must be added separately.
3. Use RISA to calculate the dead load and live load demands based on the selected depth of cover soil and soil modulus values. This yields two "flat files" of RISA output, one for dead load and one for live load.
4. Use CULVLR to establish culvert capacity, interpret dead load and live load demands, and calculate load rating factors by critical section.

With this information, the load rater determines the Level 3 inventory rating and operating rating values for each culvert segment.

B. GENERALIZED STEP-BY-STEP PROCEDURE FOR DETERMINING DEMAND LOADS

This chapter focuses on calculation of demand loads using analytical (computer) modeling for the Level 3 analysis approach. For this level of analysis, the following step-by-step procedure applies:

- Demand Step 13.** Obtain load rating parameters necessary to define each aspect of the computer model: dimensional data, strength properties for steel and concrete, soil properties, and loads (these are load rating tasks 1 through 4, previously described).
- Demand Step 14.** Create the analytical model by laying out the nodes and members and identifying the critical sections for the culvert.
- Demand Step 15.** Apply appropriate boundary conditions.
- Demand Step 16.** Calculate the magnitude of dead and live loads for all stress distributions.
- Demand Step 17.** Apply the dead and live load stress distributions to the culvert model.
- Demand Step 18.** Perform demand calculations. That is, perform a series of computer runs as necessary to define the envelope of demand moments, shears and axial thrusts at each critical section.
- Demand Step 19.** After determining the demands, use Equation 13 to check that actual thrust demand is lower than the incidental axial load assumed in the moment capacity equations. It is assumed throughout this *Guide* that Equation 13 will always be satisfied. However, if this check is not met, the capacities must be recalculated using beam-column theory as described in AASHTO *SSHB* section 8.16.4.3.
- Demand Step 20.** This step moves beyond calculation of the demand loads. Once the demand moments, shears and thrusts are established for each critical section in the culvert, these must be combined with the corresponding capacity values to determine the rating factor for both inventory and operating conditions per Equation 1.
- Demand Step 21.** The controlling rating factor for each critical section is determined by selecting the minimum rating factor, for both inventory and operating conditions, based on the maximum and minimum values for each type of load (moment, shear and thrust) for each load case.
- Demand Step 22.** If shear controls the inventory and operating ratings, the load rater should perform a less-conservative analysis of the shear failure mode based on shear critical sections as per the provisions in Section C of this chapter.
- Demand Step 23.** The controlling rating factors for the culvert are the minimum rating factors for both inventory and operating conditions.

The following sections of this chapter provide details of this step-by-step procedure, as it applies to each level of analysis.

C. LEVEL 3 SOIL-STRUCTURE INTERACTION MODEL.

1. ASSUMPTIONS

The assumptions associated with a two-dimensional finite element model are similar to the two dimensional frame analysis with extensions and modifications for using finite elements to model soil behavior and loading.

- AASHTO vehicle load distributions are applied in the transverse (in plane) direction.
- Body weight of soil elements accurately model soil dead loads.
- A one foot ($b = 1$ ft) section of the culvert may be analyzed.
- No hydrostatic pressure (water) inside the culvert.
- Supporting soils are fully drained, i.e. no hydrostatic pressure outside the culvert.
- Moments resulting in tension on the inside face of the culvert are positive.
- Moments resulting in tension on the outside face of the culvert are negative.

2. MODEL DIMENSIONS

The culvert model dimensions for Level 3 are exactly the same as those for Level 1. Refer to Chapter 9, Section C and Figure 25 for details. If the load rater has already developed a Level 1 culvert model, this can be directly appropriated into the Level 3 analysis.

In addition to the culvert structure, Level 3 requires modeling the subsurface regime; that is, the soil surrounding the culvert. Figure 34 illustrates the extent of the soil-structure model. The overall limits of the soil model relative to the culvert are D above, $1.5H$ below, and $2S$ on either side of the culvert.

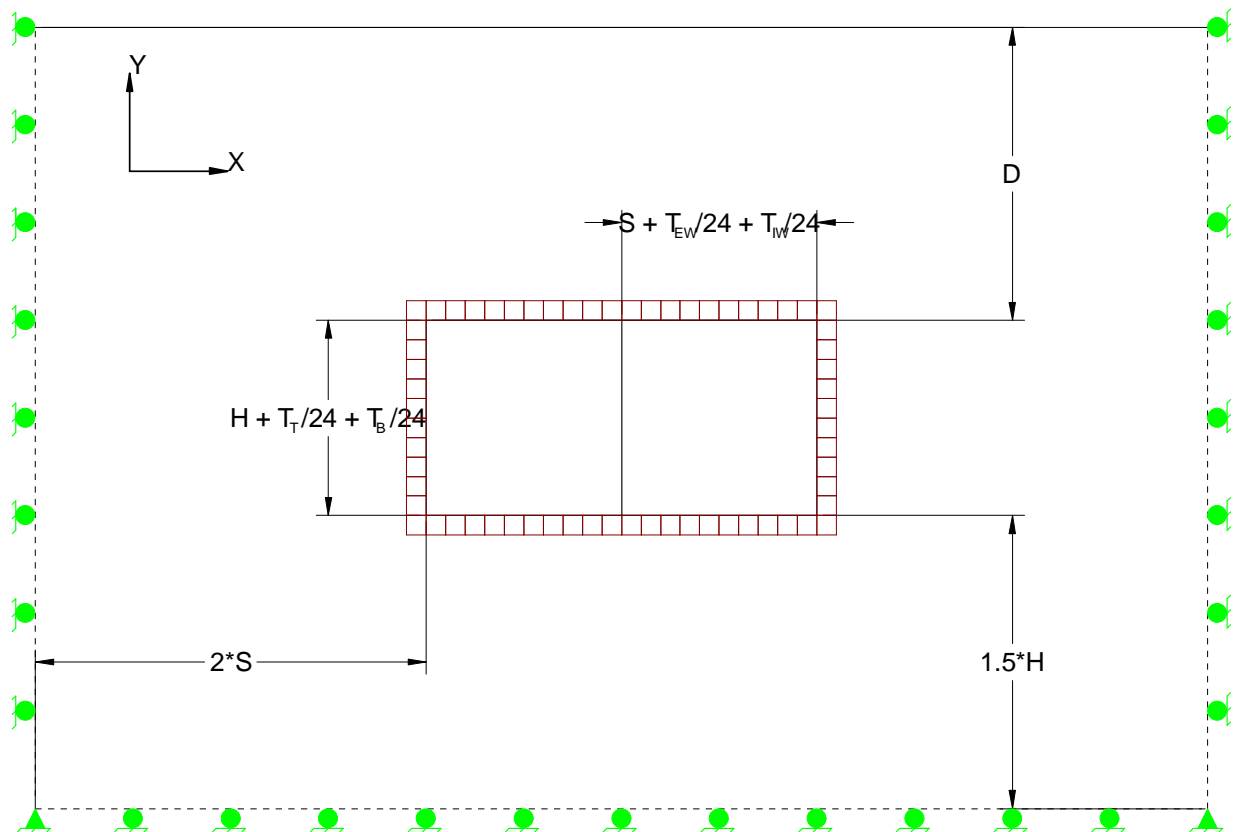

FIG 34. Soil Structure Interaction Model Layout.

When creating a submesh of the soil elements, it is necessary to define at least 10 soil elements along *each span* of the culvert. Any decrease in the number of soil elements adjacent to the culvert structure will result in significant error relative to how soil loads are transmitted to the culvert model. Soil elements should be approximately square.

3. BOUNDARY CONDITIONS

Boundary conditions for the Level 3 model must mimic continuous soil surrounding the culvert. This means that the outside edges of the model space (soil) will be restrained in the global X direction, while the bottom edge of the model space (soil) will be restrained in the global Y direction. The culvert portion of the model is not restrained by boundary conditions for the Level 3 model.

4. LOADS

Loads for the Level 3 model differ from the Level 1 model because the soil is part of the modeled system and is no longer another load applied to the culvert frame.

This means that all dead loads, both for soil and for the culvert, should be modeled by the body force (gravity) on the respective finite elements.

Live loads must still be established using AASHTO traffic loading guidelines. However, for Level 3, the only traffic load is the vertical live load, LL_{VT} . This traffic load must be converted to point loads which are applied to the “soil” (or pavement) surface. This is conceptually different from the LL_{VT} calculations for Level 1.

Previously, LL_{VT} represented a distributed load applied to the *culvert model*. The magnitude of LL_{VT} corresponded to an attenuated traffic pressure calculated based on the depth of fill, the wheel load, the culvert span, the impact factor, the number of lanes, and the number of trucks. In other words, the live load pressure acting on the culvert surface was much reduced (attenuated) from the tire contact pressure due to the distance between the point of application (where the rubber hits the road) and the culvert top slab (located some distance below ground surface). The attenuation calculations account for prismatic spreading of the load with depth, both in-plane (parallel to culvert cross section) and out-of-plane (perpendicular to culvert cross section).

For Level 3, the in-plane traffic pressure (wheel load) is modeled directly, since it can be directly applied to the soil surface. The modeling challenge, therefore, is to define the magnitude of this pressure (LL_{VT}) such that it reasonably accounts for out-of-plane attenuation at the culvert surface. To accomplish this, the traffic load is distributed over a certain distance in the out-of-plane direction to establish the distributed load applied to the culvert top slab. This attenuated load, which is a modified type of LL_{VT} specifically for a Level 3 model, is applied as a point load to the surface soil elements.

For this *Guide*, the vertical live load has been expressed in terms of 10 distinct equations derived from AASHTO (AASHTO 2014). These 10 equations are collectively designated as Equation 23.

As with the Level 1 model, for a given culvert, the load rater must select one of the 10 equations to determine the magnitude of the vertical live load. Two variables govern selection of the appropriate live load equation. The first is the number of lanes passing over the culvert. The second variable is the depth of fill, D . This fill depth will yield the proper load configuration as per the AASHTO stress distribution. Taken together, the number of lanes and the fill depth establish the controlling number of trucks and identify the proper equation to use for LL_{VT} .

EQ 23. VERTICAL LIVE LOAD APPLIED TO THE TOP SOIL MASS FOR LEVEL 3 ANALYSIS, LL_{vT} (klf)

<i>Number of Traffic Lanes</i>	<i>Depth of Fill D (ft)</i>	<i>Magnitude LL_{vT} (klf)</i>	<i>Controlling No. of Trucks</i>
1	$0 < D < 2'$	$LL_{vT} = \frac{(1 + IM) * P}{4 + 0.06 * S}$	1 truck
1	$2' < D < 3.8'$	$LL_{vT} = \frac{(1 + IM) * P}{1.15 * D + 1.67'}$	1 truck
1	$3.8' < D$	$LL_{vT} = \frac{2 * P}{1.15 * D + 7.67'}$	1 truck
2	$0 < D < 2'$	$LL_{vT} = \frac{(1 + IM) * P}{4 + 0.06 * S}$	1 truck
2	$2' < D < 3.8'$	$LL_{vT} = \frac{(1 + IM) * 2 * P}{1.15 * D + 5.67'}$	2 truck
2	$3.8' < D$	$LL_{vT} = \frac{4 * P}{1.15 * D + 17.67'}$	2 trucks
3+	$0 < D < 2'$	$LL_{vT} = \frac{(1 + IM) * P}{4 + 0.06 * S}$	1 truck
3+	$2' < D < 3.8'$	$LL_{vT} = \frac{(1 + IM) * 2 * P}{1.15 * D + 5.67'}$	2 truck
3+	$3.8' < D < 9.4'$	$LL_{vT} = \frac{4 * P}{1.15 * D + 17.67'}$	2 trucks
3+	$9.4' < D$	$LL_{vT} = \frac{.9 * 6 * P}{1.15 * D + 27.67'}$	3 trucks

where: LL_{vT} = the vertical live load on the top slab (ksf)

IM = the impact factor from Table 2

S = the clear span of a single box (ft)

P = either 4 or 16 kips as indicated in Figure 35

D = cover soil depth (ft)

The modified point loads are applied to the top of the soil as *moving loads* as per the HS-20 load pattern moving from right to left and left to right. Here the HS-20 load is shown both because it is commonly used and is illustrative. However, CULVLR 2.0 handles loads other than HS-20.

Figure 35 illustrates the center-to-center spacing for the modified point loads for HS-20. Just to be clear, the modified point loads are applied to the "soil" (or pavement) surface as point loads, not as tire contact pressures.

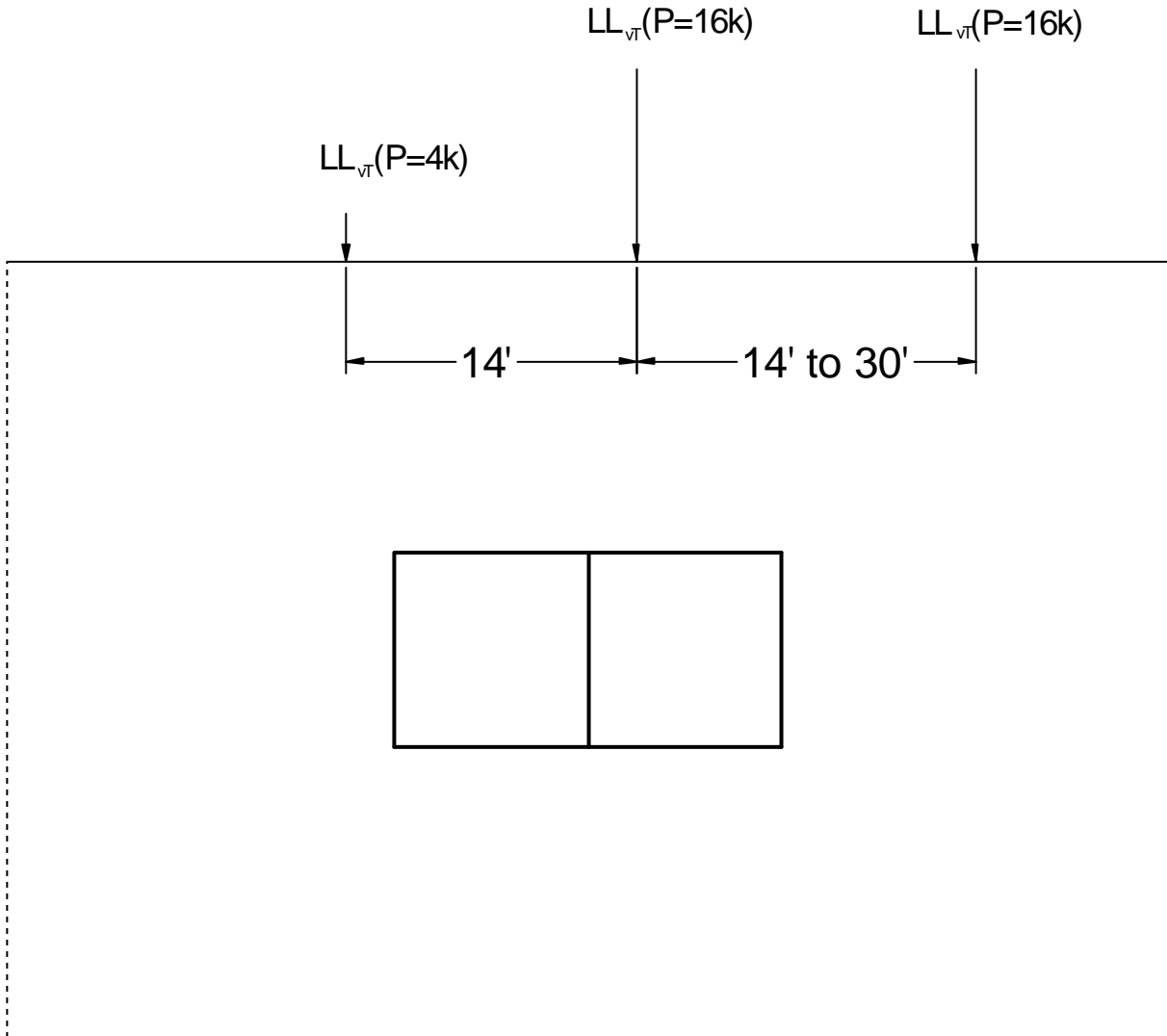

FIG 35. Live Load Distribution for 2D Finite Element Model with Soil Structure Interaction.

5. LOAD CASES

The Level 3 approach directly models the culvert-soil interaction, so there are no externally-applied lateral loads. This means there is no need for the “total” and “reduced lateral” load cases as per the Level 1 analysis. The demand at corner critical sections and midspans for the Level 3 analysis is what it is.

6. DEMAND LOAD CALCULATIONS

Having created the analytical model, defined the boundary conditions, and determined the magnitude and extent of loads, the next step is to calculate the moment, shear and thrust demands. This requires application of an appropriate structural analysis software package, as discussed in the following section of the *Guide*.

D. ANALYTICAL PROGRAM – RISA-3D

1. OVERVIEW

Numerous computer programs are available to perform two-dimensional, finite-element modeling of the culvert-soil system. Some have their origins in structural modeling, such as RISA. Others have their origins in geotechnical modeling, such as PLAXIS. Still others have been specifically designed with culverts/buried pipes in mind and feature both complex structural response systems and multiple soil models, such as CANDE. Still more powerful finite element and finite difference programs, such as ABAQUS and FLAC, are available which can model complex structure geometries and represent nonlinear variation of soil stiffness with strain and anisotropy.

Notwithstanding the technological pull of increasingly complex programs available for modeling the culvert-soil system, certain features of the *culvert rating problem* suggest that for many applications, flexibility and ease-of-use are preferable to computational sophistication. First, culvert load rating requires application of a moving load across the culvert-soil system, and this necessitates specification of a non-symmetrical analytical model. Default models for this application are not available, so they must be generated from the most basic input fields. Setting up models this way is tedious, time-consuming, and highly susceptible to user error.

Second, project-specific data for the culvert and soil engineering properties are rarely available. Most raters will use default parameters for concrete and steel (taken from the construction drawings), and they will assume basic strength parameters for soil. This practice is not unreasonable, and is the rule rather than the exception. However, the potential for error introduced by these typical practices will, in most situations, overshadow benefits that a more complex analytical model may bring to the solution. This means that much of the benefit – that is, more refined determination of the moment, shear and thrust demands – from the more advanced programs is rarely, if ever, realized.

A third factor is that culvert rating calculations do specify dead and live loads, but they do not presume to specify the extent to which the culvert can suitably support these loads. That is what the rating process is meant to determine. Thus, a “weak” or “flexible” culvert will not support the applied load – it will fail either by excess deflection or inadequate structural capacity. The more complex structure and soil models will certainly depict this failure. But while predicting failure for a weak culvert is a good thing, it does not yield a load rating. It simply shows a particular culvert will not work. This means that with the more complex analytical models, determination of the load rating for a weak culvert may require iterative reduction of traffic loads until the culvert does not fail. This manual convergence solution approach adds more work to the culvert rating process.

With these factors in mind, for the purposes of Level 3 analyses under this *Guide*, the decision has been made to recommend using RISA-3D with linear-elastic finite elements to model the soil structure interaction. RISA-3D seems to reasonably balance computational rigor against the unique requirements of the culvert rating problem.

2. RISA-3D STRENGTHS AND LIMITATIONS

The RISA-3D program has some notable strengths that make it an ideal choice for a Level 3 culvert load rating program. These are:

- Program inputs are graphically based
- Deflections, shear, thrust and moments can be represented and analyzed graphically

- The program models in-plane behavior of plates very well
- Generality allows for intermediate boundary conditions
- Critical section demands can be determined directly

One limitation to using RISA-3D is that the constitutive models for both concrete and soil are limited to the linear elastic model. However, as noted above, this approach allows for direct calculation of the rating factor.

3. RISA-3D STEP-BY-STEP INSTRUCTIONS

Culvert load rating for Level 3 using the RISA-3D program can be accomplished by following these steps. This sequence assumes the load-rater has already defined the input parameters and is prepared to create the RISA-3D analytical model.

RISA-3D Step 1. Modify the model created for the Level 1 analysis to match Figure 34 through the following steps:

- a. Level 3 load rating is a 2D analysis. The process does not use the 3D capability of RISA.
- b. Place new nodes at the outside corners of the soil area as well as at the edges directly above, below and outside the outside corners of the culvert according to Figure 34.
- c. Connect the nodes from RISA-3D Step 1.b using the plate drawing tool to make eight large soil elements surrounding the culvert and filling the soil area.
 - i. The elements should have the material properties from Table 7.
 - ii. The elements should be 12 in. thick.
- d. Use the “submesh” tool to automatically submesh the large plates. Be sure to specify a minimum of 10 elements along each culvert span.
- e. Create a thin soil (pavement) “beam” at the ground surface, running from the top left corner of the soil area to the top right corner. This is necessary to facilitate the application of the moving live load. It is required by a limitation in RISA-3D which requires moving loads to be applied to beams only.
- f. Set the boundary conditions for the outside edge of soil mesh, as shown in Figure 34.

RISA-3D Step 2. Establish the RISA load cases for dead load and live load, as discussed in Chapter 10, Section C.

- a. The dead load is simply a -1 gravity loading in the Global Y direction
- b. The live load is a moving load of magnitude and spacing as illustrated in Figure 35 and calculated in Equation 24 along the soil (pavement) “beam” created in RISA-3D Step 1.e. Use the check box to run the load both directions along the beam.

RISA-3D Step 3. Use RISA-3D to solve for moment, shear and axial dead and live loads separately. This will require two separate computer runs, one for each load combination.

RISA-3D Step 4. Record the maximum and minimum demands at each critical section from the member forces table.

RISA-3D Step 5. Use Equation 13 to check that actual thrust demand is lower than the incidental axial load assumed in the moment capacity equations.

RISA-3D Step 6. This step goes beyond calculation of demand loads and has to do with calculating the culvert load rating. Per the culvert rating procedure, calculate Inventory and Operating rating factors for each critical section, for each demand type, for each load case per Equation 1.

When calculating the rating factors, exercise extreme care regarding the signs for both demands and capacities.

- a. Live load and capacity must be in the same sign and direction.
- b. If the live load and dead load are in opposite directions or the calculated rating is negative, a check should be made to ensure that the structure has adequate capacity to support the dead load. i.e. $C \geq 1.3D$

RISA-3D Step 7. Select the controlling inventory and operating rating factors for each section.

RISA-3D Step 8. Select the overall controlling rating factors for the culvert.

RISA-3D Step 9. If shear controls the load rating, the load rater should perform a less-conservative analysis of the shear failure mode based on shear critical sections as per the provisions of Chapter 8, Section C.

RISA-3D Step 10. Calculate the Inventory and Operating Ratings per Equation 2.

The above process is a statement of the basic order of operations for the Level 3 load rating analysis. Refer to CULVLR 2.0 for details.

E. CULVLR 2.0 SOFTWARE – LEVEL 3 ANALYTICAL MODEL

Level 3 load rating represents a culminating structural engineering task of the culvert load rating process. Here the load rating engineer uses the analytical model for a culvert segment to systematically calculate capacities, demands, and rating factors at each critical section. CULVLR 2.0 performs this subtask as part of the Level 3 load rating task. The load rater is directed to the Help File accompanying the CULVLR 2.0 software for further information.

F. EXAMPLE PROBLEM – LEVEL 3 ANALYTICAL MODEL

Appendix E of this *Guide* includes a worked examples for the Level 3 load rating calculations using RISA-3D for the demand model. This example incorporates not only the basics of the Level 3 rating process but also the details and additional features of CULVLR relative to the soil model, alternative vehicle loads, the pavement model, and other variables.

G. REPORTING LEVEL 3 LOAD RATING RESULTS

Upon completion of the Level 3 analysis, the load rater will want to report the load rating results which is the seventh and final task of the load rating process. The culvert rating program, CULVLR 2.0, allows descriptive input about the culvert structure as a means to provide context for all segment level load rating data.

However, individual culvert load rating reports for Level 3 analysis are reported at the culvert segment level. CULVLR 2.0 offers various reporting options. The load rater may publish a Level 3 summary report, the summary plus input, or a comprehensive report for the segment. The comprehensive report includes not only the input but also the capacities, the moment, shear and thrust demands, and the rating factors for all critical sections of the culvert segment.

Appendix F of this *Guide* includes a worked examples for reporting the results of Level 3 load rating calculations.

11. THE GENERAL ANALYTICAL MODEL FOR CULVERT LOAD RATING

A. OVERVIEW

The general case for culvert modeling is a Level 4 analysis. Level 4 is the most sophisticated of the modeling approaches and uses a two or three-dimensional finite element model of the soil-structure system. Level 4 modeling would typically be used for research or other specialized applications.

B. THE LEVEL 4 ANALYSIS DEFINED

Level 4 analyses go beyond the computational sophistication of the Level 1 and Level 3 analyses discussed in this *Guide*. The Level 4 analysis for culvert load rating means the engineer uses a more advanced modeling approach to determine culvert load demands, culvert capacity, or both. Level 4 analyses will, at a minimum, model soil-structure interaction effects. Level 4 analyses may use either two-dimensional or three-dimensional models for the culvert-soil system.

It is important to emphasize that Level 4 means a higher level of analytical sophistication and not better quality input. Each of the modeling approaches described in this *Guide* (Level 1 or Level 3) allows the use of default input parameters such as may be obtained from policy, from construction drawings, or from this *Guide*. Results from these same modeling approaches may be *enhanced* by using project-specific input parameters, such as actual concrete compressive strength values, actual reinforcing steel tensile strength values, actual soil modulus values, and so on. However, for Level 4 modeling, it is assumed that project-specific values will always be used. The point is that a more sophisticated model warrants more refined project inputs. It is probably a waste of effort to create a Level 4 culvert model but populate it with default or handbook material parameters.

It is also important to emphasize that the goal of a Level 4 analysis is a more accurate assessment of the live load capacity of the culvert structure; *i.e.*, a *better* load rating. Usually, but not always, this translates to a higher load rating than would be obtained from one of the lesser analyses. This is because Level 4 models demand loads (moments, shears, and axial thrusts) in a more refined way, and when the demands are more correctly modeled, they are generally less over-conservative. But nothing in the load-rating process requires that the inventory and operating ratings from a Level 4 analysis be higher than for a Level 3 analysis.

C. WHEN TO USE A LEVEL 4 ANALYSIS

As discussed in Chapter 3 of this *Guide*, the level of analysis chosen is a trade-off between sophistication of analysis and required work effort. The simpler methods are frequently selected as a first choice due to the need to analyze many structures with limited resources.

When a lower-level analysis yields satisfactory results, there is typically no need to use a more sophisticated model. Satisfactory results would be the establishment of safe load carrying capacity that does not require posting the structure and does not unduly restrict the flow of permitted overweight

trucks. A more sophisticated analysis is justified to avoid posting the structure or to ease restrictions on the flow of permitted overweight trucks.

Typically, then, a Level 4 analysis may be justified when a Level 3 analysis (performed using project-specific input parameters) indicates that a culvert must be load-posted, even when in the judgment of the engineer-inspector, load-posting is not necessary. Economics also enters into the decision-making process. The engineer must evaluate the cost and effort associated with conducting a Level 4 analysis against alternative courses of action.

Level 4 analysis may also be required if the culvert is anything other than a reinforced concrete box culvert. Reinforced concrete box culverts are the most common type of culvert used by TxDOT, and the Level 1 and Level 3 analyses presented in this *Guide* assume that the structure *is* a reinforced concrete box culvert. However, if the culvert is manufactured from other material such as aluminum, plastic, or steel, or if the culvert shape is other than rectangular box such as an arch or a pipe, the Level 4 analysis will be required.

Research-oriented studies are another potential application for Level 4 analyses. For example, interpretation of load test data for a culvert structure might require comparison of member stresses obtained from the load test with predicted stresses obtained from culvert modeling. In this case, the use of more sophisticated models is probably warranted.

The important thing to keep in mind is that the Level 4 analysis represents the most general modeling approach, but requires the most specific project input parameters. This means that considerable cost, effort and time will be required both to create the Level 4 analytical model, to obtain the input parameters from which the model will yield meaningful results, and to calibrate the model.

D. COMMENTS ON TWO-DIMENSIONAL VS. THREE-DIMENSIONAL MODELS

Both two-dimensional and three-dimensional finite-element models can be used for a Level 4 analysis of the culvert-soil system. Numerous computer programs are available to create these models. Comments are as follows.

1. LEVEL 4 ANALYSIS WITH A TWO-DIMENSIONAL MODEL

If a two-dimensional model will be used for a Level 4 culvert load-rating analysis, the recommended computer program for determining demand moments, shears and thrusts is CANDE (**C**ulvert **A**nalysis and **D**esign). First introduced in 1976 under the sponsorship of FHWA, CANDE is a special-purpose, public-domain finite element program that is used worldwide for the structural design and analysis of buried culverts. CANDE is viewed as highly trustworthy, having been carefully documented and validated through more than 30 years of engineering research and consulting applications. It is computational rigor that makes CANDE superior to the Level 3 model discussed in this *Guide* (RISA-3D).

CANDE was upgraded under NCHRP Project 15-28 to create CANDE-2007 and features complex structural response systems and multiple soil models (Mlynarski 2008). CANDE-2007 provides an elastic solution (CANDE Level 1), automated finite element mesh generation for common configurations (CANDE Level 2), and a user-defined finite element mesh (CANDE Level 3), all in two dimensions. Enhancements over earlier versions of CANDE include an updated finite element analysis engine and graphical tools for interpreting the CANDE output. Documentation for CANDE-2007 includes the *User*

Manual and Guideline, Solution Method and Formulations, and Tutorial of Applications. These are installed with the program.

Relative to culvert load rating, CANDE's primary benefits are: (a) an advanced reinforced concrete constitutive model featuring a tri-linear curve in compression and an abrupt tension rupture at initial tension cracking, (b) five alternative soil models to choose from including isotropic elastic, orthotropic elastic, overburden dependent, Duncan and Duncan/Selig, and extended Hardin, (c) the ability to model culvert construction in increments, and (d) calculation of culvert performance in terms of stress-dependent demand-to-capacity ratios. CANDE also includes subroutines to directly facilitate analysis of culvert types other than reinforced concrete boxes.

Notwithstanding its superior computational rigor, CANDE was not specifically designed for culvert load rating and thus is *not* very user-friendly for load rating applications. To load-rate a culvert using CANDE-2007, the user must rely on a *CANDE Level 3 analysis* (the most general level for CANDE). Even when the user is very familiar with the CANDE program, creation of the user-defined finite element mesh and application of moving loads are highly tedious and very time-consuming. Whereas a structural engineer familiar with RISA can likely perform a Level 3 analysis (as discussed in this *Guide*, using RISA with LEFE) in a few hours, load rating the same culvert using CANDE could take days.

Research is ongoing per NCHRP project 15-54 (2015-18) that may result in improvements to CANDE specifically relative to load rating.

2. LEVEL 4 ANALYSIS WITH A THREE-DIMENSIONAL MODEL

When investigating the performance of culverts with shallow cover subjected to live loads, it has been recognized that three-dimensional attenuation of the live load takes place both through the soil and the structure. In most cases evaluating live load effects in two dimensions leads to conservative designs, as the longitudinal distribution of load is underestimated. Thus, three-dimensional analysis of the load-rating problem should lead to better results.

However, several modeling issues must be suitably addressed to solve the three-dimensional culvert rating problem. These include but are not limited to specification of the structural model, modeling the vehicle (live load) geometry, selection of the soil and reinforced concrete constitutive models, inclusion of soil shear failure and stiffness variation with depth, modeling of longitudinal bedding to support the culvert structure, and modeling of culvert joint effects. To this end, a Level 4 analysis based on three-dimensional modeling of the culvert-soil system represents the most advanced approach to culvert load rating.

Several software programs can be used for three-dimensional culvert load rating applications, some of the more prominent examples being ABAQUS, ANSYS, FLAC3D, and PLAXIS. Among commercially-available software programs suitable for three-dimensional modeling, ABAQUS stands out. ABAQUS is a general-purpose finite element analysis code, but it has been successfully programmed to provide realistic simulations that allow accurate predictions of soil deformations and soil-structure interactions. ABAQUS features a well-developed graphical interface and compatibility with various CAD programs which enhance its usability.

E. PRACTICAL CONSIDERATIONS FOR LEVEL 4 CULVERT LOAD RATING ANALYSES

This *Guide* recognizes a hierarchy of analysis for performing the demand calculations, with Level 4 being the most general and the most sophisticated modeling approach. Level 4 analyses are warranted only for specialized applications. Typically, a Level 4 culvert load rating analysis would be done only if a Level 3 analysis based on project-specific input data fails to yield satisfactory results.

Level 4 analyses require high-quality, project-specific input data for the culvert structural properties, soil properties, and vehicle loads. Because Level 4 analyses are the most general, they are also the most complex and difficult to create. Numerous engineering decisions must be made to fully specify the model.

Successful modeling at Level 4 presumes that the load rater has a strong background in structural modeling in general and the culvert load rating process in particular. Even under these conditions, it should be expected that Level 4 analyses will be highly complex, time-consuming, and costly to perform.

F. LEVEL 4 NOT SUPPORTED BY CULVLR 2.0 SOFTWARE

The CULVLR 2.0 software was created to perform production-simplified load rating using the Level 3 approach which was calibrated for and specifically relies on (simple) linear-elastic constitutive models for concrete and soil behavior. For this reason, CULVLR 2.0 does not support Level 4 analytical modeling at this time. This *Guide* does not contain a worked example for Level 4 load rating.

G. NONDESTRUCTIVE LOAD TESTING

This *Culvert Rating Guide* articulates policy, procedures, and practices for load rating of existing bridge-class culvert structures using analytical methods having various degrees of sophistication. However, it is possible to directly measure the capacity of a culvert structure under load using a nondestructive load test. Typically this is done when the results from analytical methods of evaluation do not accurately represent the true behavior and load distribution of the structure and its components (*MBE* Article 6A.3.4). An example would be a bridge with no visible signs of distress but whose calculated load rating indicates the bridge needs to be posted.

MBE Article 8.8 provides technical guidance on performance of load tests for rating of bridge structures. The basic idea is that “diagnostic and proof load tests can be employed to improve the evaluator’s understanding of the behavior of the bridges being tested and to identify and quantify in a scientific manner their true inherent reserve capacity.” The *TxDOT Bridge Inspection Manual* briefly mentions nondestructive load testing but provides little guidance other than to note that such testing is “costly” and the results are “open to interpretation.”

Results from the research that supports this *Culvert Rating Guide* – in particular the load rating of a sample of 1,000 TxDOT culverts – indicate that the calibrated Level 3 model recommended herein provides reasonably accurate and precise load rating factors, generally consistent with the culvert condition rating identified from NBI inspections. However, it is certainly possible that, for various reasons, Level 3 results may not align well with observed structure behavior. In such cases, a nondestructive load test may be appropriate. The load rating engineer should refer to the *MBE* Section 8 for guidance on planning, designing, performing and interpreting the results from field load tests.

12. LIMITATIONS

A. OVERVIEW

This *Culvert Rating Guide* has been developed in order to present a clear, repeatable and valid procedure for TxDOT engineers and their consultants to use when load rating culverts in the TxDOT roadway system. Through a series of TxDOT research projects, the analytical approaches described herein were validated by load rating a representative sample of TxDOT culvert designs from each of TxDOT's culvert design eras, by performing a parametric study, and through comparative analyses using data from a limited field instrumentation and load test program consisting of three reinforced concrete box culverts bedded in drained, low-to-medium quality backfill soil under low depth of fill. While the principles outlined in this *Guide* are applicable to other applications, because of inherent diversity of many aspects of the culvert load rating process including culvert type, soil backfill conditions, drainage, analytical modeling tools, and others, certain limitations must be noted.

B. CULVERT TYPE

This *Guide* was developed for load rating cast-in-place reinforced concrete box culverts, which are the most common type of culvert used by TxDOT. The load rating methods presented herein have not been explicitly evaluated for other culvert materials such as plastic, steel, or aluminum. Precast concrete box culverts may be modeled using techniques similar to those outlined in this *Guide*; however, the capacity equations for precast concrete box culverts presented in AASHTO's *SSHB* and *MBE* are slightly different from those outlined here for reinforced concrete box culverts. Round pipes, arch, and other culvert shapes behave very differently from box culverts and this *Guide* does not present tools and procedures to model these other culvert shapes.

C. FILL DEPTH

TxDOT's culvert designs model fill depths ranging from zero (direct traffic) to deep fill (in excess of 20 feet). Parametric studies indicate that the deeper the fill, the more soil-structure interaction influences culvert behavior. However, the field instrumentation program (research project 0-5849) only evaluated culverts having four feet or less of fill. While the procedures outlined in the *Guide* can be used to load rate deep fill culverts, it will be especially important to validate the soil parameters used for demand modeling.

D. BACKFILL DRAINAGE

Submerged culverts and culverts in undrained, saturated soils exist in various parts of the state, in particular, along the Texas Gulf Coast and in high-rainfall areas of East Texas. The research associated with this project did not explore or consider the effects of water on the structural component of culvert behavior.

E. SOIL PARAMETERS

The load rating analyses and parametric studies upon which this *Guide* is based indicate that the rating factor is sensitive to certain soil parameters and conditions, in particular, the soil modulus value used for Level 3 analyses. Both published literature and the field instrumentation test program for research project 0-5849 suggest that soil modulus values for a given soil may vary by as much as one to two orders of magnitude depending on overburden stress, drainage, the method used to determine modulus, and other factors. While the *Guide* does offer recommended values for the soil parameters, these values should be used with caution and engineering judgment.

F. ANALYTICAL MODEL

This *Guide* has given preference to analytical models and structural analysis software suitable for production load rating of culverts. This is as opposed to models/software primarily intended for culvert design and analysis, or for research. Structural analysis models and software which incorporate more sophisticated constitutive models for the culvert and the soil exist, and these may be used for load rating as per the discussion in Chapter 11 on Level 4 culvert load rating analyses.

REFERENCES

- AASHTO. (2002). *Standard Specifications for Highway Bridges* (17th ed.). Washington, D.C.: American Association of State Highway and Transportation Officials.
- AASHTO (2008). *Mechanistic–Empirical Pavement Design Guide*. Washington D.C.: American Association of State Highway and Transportation Officials.
- AASHTO (2011). *Manual for Bridge Evaluation, 2nd Edition, with 2011, 2013, 2014, 2015, and 2016 interim revisions*. Washington DC: American Association of State Highway and Transportation Officials.
- AASHTO. (2014). *LRFD Bridge Design Specifications, U.S. Customary Units, 7th Edition*. Washington D.C.: American Association of State Highway and Transportation Officials.
- Code of Federal Regulations (2016). 23 CFR 650 Subpart C National Bridge Inspection Standards. <https://www.gpo.gov/fdsys/pkg/CFR-2016-title23-vol1/pdf/CFR-2016-title23-vol1.pdf>. Accessed 9/16/2016.
- Committee for the Truck Weight Study (1990). *Truck Weight Limits: Issues and Options. Special Report 225*. Washington, DC: Transportation Research Board.
- Federal Highway Administration. (1986). *Culvert Inspection Manual*. Washington, D.C.: U.S. Department of Transportation.
- Federal Highway Administration (1995). *Recording and Coding Guide for the Structure Inventory and Appraisal of the Nation's Bridges*. Report No. FHWA-PD-96-001. <https://www.fhwa.dot.gov/bridge/mtguide.pdf>. Accessed 07/30/2016.
- Federal Highway Administration (2016). "Bridge Tables / Download NBI ASCII files" <http://www.fhwa.dot.gov/bridge/nbi/ascii.cfm>. Accessed 07/30/2016.
- Federal Highway Administration (2016). "Home / Programs / Bridges & Structures / Safety / Bridge Inspection / National Bridge Inventory / Bridge Tables / Download NBI ASCII files" <http://www.fhwa.dot.gov/bridge/nbi/ascii.cfm>. Accessed 07/30/2016.
- Hagan, H. (1991). *An Informal History of the Texas Department of Transportation*. Travel Division, Texas Department of Transportation (updated 2000)
- Kulicki, J.M. and Mertz, D.R. (2006). "Evolution of Vehicular Live Load Models During the Interstate Highway Design Era and Beyond." *50 Years of Interstate Structures: Past, Present and Future. Transportation Research Circular E-C104*. Washington, DC: Transportation Research Board.
- Lawson, W.D., T.A. Wood, C.D. Newhouse, and P.W. Jayawickrama (2010). *Evaluating Existing Culverts for Load Capacity Allowing for Soil Structure Interaction FHWA/TX-10/0-5849-1*. Austin, TX: Texas Department of Transportation.

- Lawson, W.D., T.A. Wood, C.D. Newhouse, C.D. and P.W. Jayawickrama (2009). *Culvert Rating Guide*. Austin, TX: Texas Department of Transportation.
- Lawson, W.D., T.A. Wood, S.M. Morse, P.W. Jayawickrama, and C.D. Newhouse (2013). *Software Development to Implement the TxDOT Culvert Rating Guide*. FHWA/TX-15/5-5849-1. Austin, TX: Texas Department of Transportation
- Lawson, W., H. Seo, J. Surles, S. Morse, P. Jayawickrama, S. Bae, T. Wood, S. Gunerathne, B. Afolabi, M. Mousavi, and A. Javid (2016). *Load Rating TxDOT's pre-1980 In-Service Culverts: Model Enhancements, Procedure Improvements, and Results for 1,000 Structures*. FHWA/TX-16-88-4XXIA001-R1. DRAFT Report. Lubbock, TX: Texas Tech University.
- Lawson, W., H. Seo, J. Surles, and S. Morse, (2018). *Improving TxDOT's Load Rating Process and Software*. FHWA/TX-17-88-7XXIA001-R1. FINAL Report. Lubbock, TX: Texas Tech University.
- Mlynarski, M. (2008). *Modernize and Upgrade CANDE for Analysis and Design of Buried Structures*. The National Academies. Washington, DC: Transportation Research Board .
- Mlynarski, M., Katona, M. G., & McGrath, T. J. (2008). *CANDE-2007 Culvert Analysis and Design User Manual and Guideline*. Moon Township, PA: National Cooperative Highway Research Project NCHRP 15-28.
- NCHRP 15-54 [Active] (2015). *Proposed modifications to AASHTO culvert load rating specifications*. Washington DC: National Academy of Sciences.
<http://apps.trb.org/cmsfeed/TRBNetProjectDisplay.asp?ProjectID=3869>. Accessed 07/30/2016.
- RISA Technologies, LLC (2012). *RISA-3D Version 10.0.1*. Foothill Ranch, CA: RISA Technologies, LLC.
- Sivakumar, B., F. Moses, G. Fu, and M. Ghosn (2007). *Legal Truck Loads and AASHTO Legal Loads for Posting*. NCHRP Report 575. Washington, DC: Transportation Research Board.
- Soil Survey Staff, Natural Resources Conservation Service, United States Department of Agriculture. Web Soil Survey. Available online at the following link: <https://websoilsurvey.sc.egov.usda.gov/>. Accessed 08/31/2016.
- TXDOT. (1918-1982) Historic Bridge and Road Specifications. *Standard Specifications for Construction and Maintenance of Highways, Streets and Bridges*. Austin: Texas Department of Transportation. <https://www.txdot.gov/business/resources/txdot-specifications/historic-bridge.html> Accessed 08/30/2017.
- TxDOT. (2003). *CULV5 - Concrete Box Culvert Analysis Program*. Austin: Texas Department of Transportation.
- TxDOT. (2003). *Concrete Box Culvert Analysis Program - CULV5 Input Guide*. Austin: Texas Department of Transportation.
- TxDOT. (2004). *CULV5 (Version 1.71) Readme.pdf*. Austin, TX: Texas Department of Transportation.

- TxDOT. (2014). *Pavement Management Information System: Raters Manual*, Austin, TX: Texas Department of Transportation.
- TxDOT. (2015). *Bridge Design Manual (LRFD)*. Austin, TX: Texas Department of Transportation.
- TxDOT. (2017). CULVLR Version 2.0 – a program for load rating reinforced concrete box culverts. Austin TX: Texas Department of Transportation.
- TxDOT. (2018). *Bridge Inspection Manual*. Austin, TX: Texas Department of Transportation.
- Wood, T.A., P.W. Jayawickrama, C.D. Newhouse, S.M. Morse, and W.D. Lawson (2013). *Load Rating TxDOT Culvert Design Standards- Volume 1: Level 1 Analysis per AASHTO Policy. FHWA/TX-12/5-5849-03-R1, Vol. 1*. Austin, TX: Texas Department of Transportation
- Wood, T.A., P.W. Jayawickrama, C.D. Newhouse, S.M. Morse, and W.D. Lawson (2013). *Load Rating TxDOT Culvert Design Standards- Volume 2: Level 3 Analysis per AASHTO Policy. FHWA/TX-12/5-5849-03-R1, Vol. 2*. Austin, TX: Texas Department of Transportation
- Wood, T.A., P.W. Jayawickrama, C.D. Newhouse, S.M. Morse, and W.D. Lawson (2013). *Load Rating TxDOT Culvert Design Standards- Volume 3: Level 1 Analysis per TxDOT Policy. FHWA/TX-12/5-5849-03-R1, Vol. 3*. Austin, TX: Texas Department of Transportation

APPENDIX A

EXAMPLE

"DOCUMENT CAPTURE AND CLASSIFICATION"

Culvert Load Rating Procedure

Culvert load rating consists of seven tasks:

- 1) Task 1: Document Capture and Classification
- 2) Task 2: Structure History and Segment Interpretation
- 3) Task 3: Parameter Interpretation and Data Capture
- 4) Task 4: Design Selection
- 5) Task 5: Level 1 Load Rating Calculation
- 6) Task 6: Level 3 Load Rating Calculation
- 7) Task 7: Review and Reporting

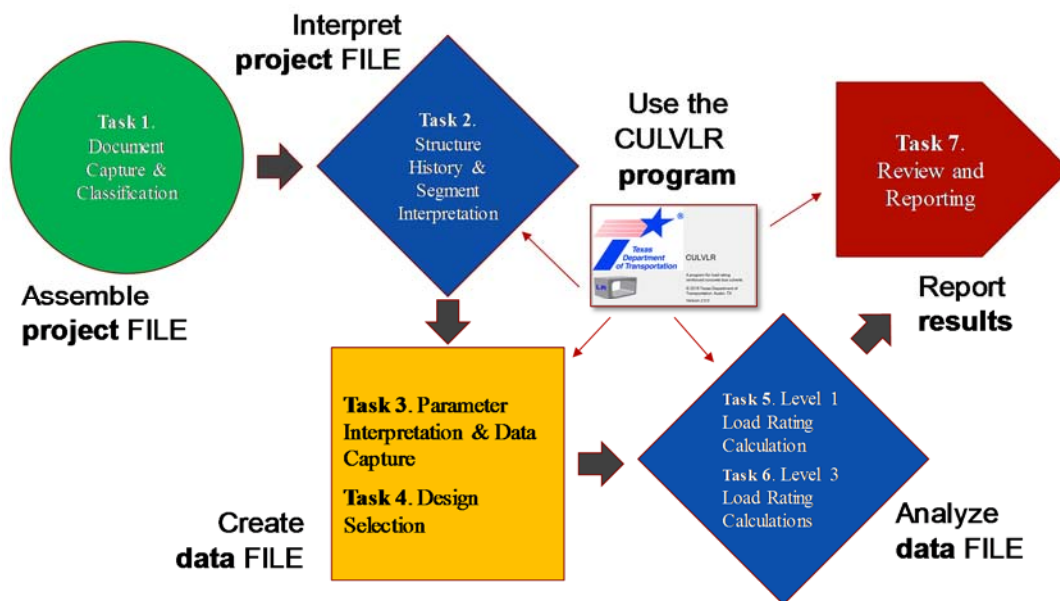

Based on the tasks, researchers at Texas Tech University developed a draft training module for culvert load rating and conducted training sessions for three TxDOT engineers from May 23 to May 25, 2017. There are total of four examples available in the training modules. The example name is consisted of two numbers separated by dot in the format of Example #.#. The first number represent module number in the training materials and the second number indicates example number. For instance, Example 3.1 indicates EXAMPLE 1 for Module 3. A total of four examples (EXAMPLE 1 through 4) are presented in the training materials. EXAMPLE 1 through 4 are associated with the following structures:

- EXAMPLE 1: 01-075-0279-04-013
- EXAMPLE 2: 01-081-2731-02-001
- EXAMPLE 3: 02-213-0259-02-008
- EXAMPLE 4: 02-182-0391-08-046

The Culvert Rating Guide presents step-by-step procedures for all seven tasks using EXAMPLE 3.

Example 2.3

Example 2.3 is about Task 1: Document Capture and Classification. All available documents for the given culvert are identified and assembled in this task.

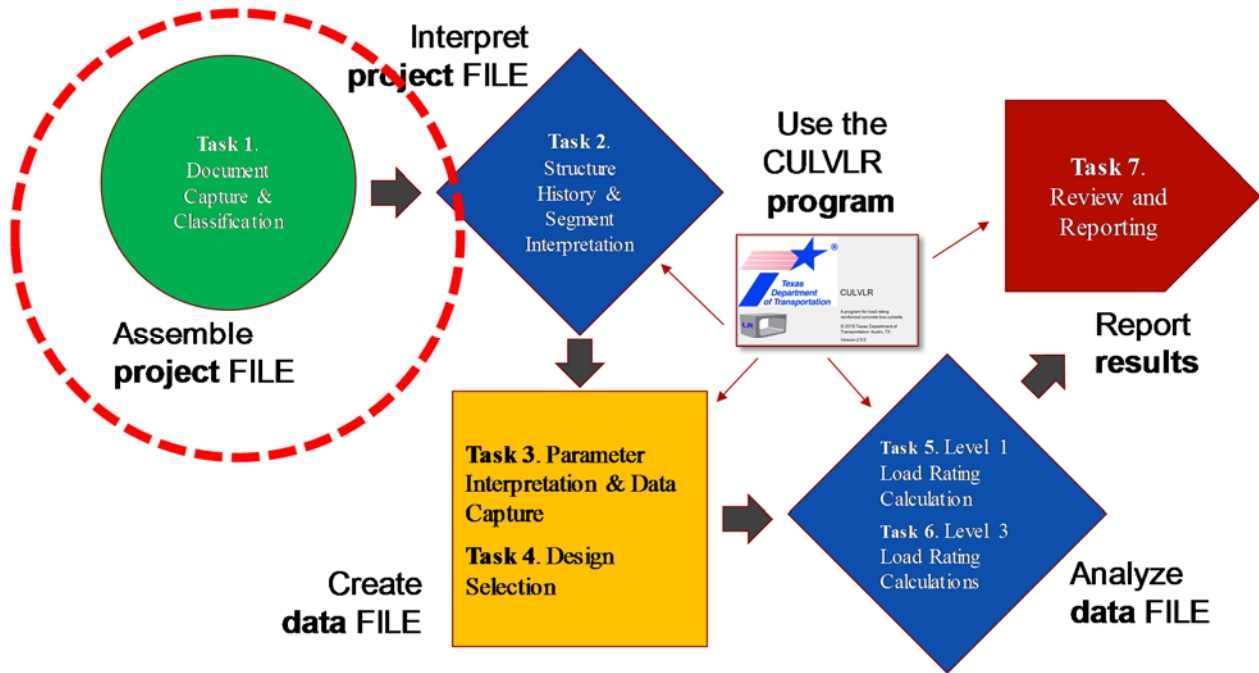

Example 2.3 is a culvert located in Somervell County of Fort Worth District. It carries US 67. Structure number for the culvert is 02-213-0259-02-008 (22130025902008).

Description of example culvert**Example 2.3**

- Structure No.: 02-213-0259-02-008 (22130025902008)
- District: 02 Fort Worth
- County : 213 Somervell
- Facility carried: US 67

Objective

- Identify and assemble all available documents for the given culvert.

Location of Example 2.3 culvert is shown below.



Documents associated with the culvert will be identified and assembled based on the following steps:

- Step 1: Identify a) culvert data and b) documents from Pontex.
- Step 2: Identify and review inspection documents
- Step 3: Look for construction documents in the construction drawing archive with the original CSJ number.
- Step 4: Check for additional construction documents using the index card file.
- Step 5: Classify and record documents for the culvert.

Step 1a) Identify culvert data from Pontex.

Culvert data available in Pontex for this culvert is shown below:

Pontex Rec.	Structure Number:	22130025902008	
		02-213-0259-02-008	
	Previous Structure Number:		
	District:	02 FTW Fort Worth	
	County:	213 Somervell	
	Control-Section-Structure:	0259 - 02 - 008	
	Original CSJ:	0259 - 02 - 010	
	Year Built:	1925	
	Description:		
		3-barrel (8' x 8') concrete box culvert	
	Location:		
		1.2 MI W OF FM 203	
	Feature:		
		WOODS BRANCH	
	Facility:		
		US 67	
	Lanes on Structure:	2	
	Lat/Long (degrees):	32.19016786 -97.85579405	
	Span Number, N:	3	
	Span Length, S (ft):	8	
	Total Span (ft):	27	
	Skew (degrees):	0	
		02-213-0259-02-008_Inspection-2012.pdf	
		02-213-0259-02-008_Photos-2012.pdf	

Key descriptive information for this culvert are:

- 3-barrel 8x8 culvert on US 67
- Bridge length: 27 ft
- Skew: 0 deg
- Year built: 1925
- CSJ: 0259-02-010

Step 1b) Identify Pontex documents.

Two documents are available from Pontex: 1) 02-213-0259-02-008_Inspection-2012.pdf and 2) 02-213-0259-02-008_Photos-2012.pdf

Span Number, N:	3	
Span Length, S (ft):	8	
Total Span (ft):	27	
Skew (degrees):	0	
	02-213-0259-02-008_Inspection-2012.pdf	
	02-213-0259-02-008_Photos-2012.pdf	

Step 2) Identify and review inspection documents.

Now, open and review the identified Pontex documents. During this process, confirm the structure number and the basic culvert data. Also, get a feel for the basic culvert information.

Step 3: Look for construction documents in the construction drawing archive with the original CSJ number.

After searching Construction Drawing Archive (CDA) for original CSJ of 0259-02-010, no documents are found.

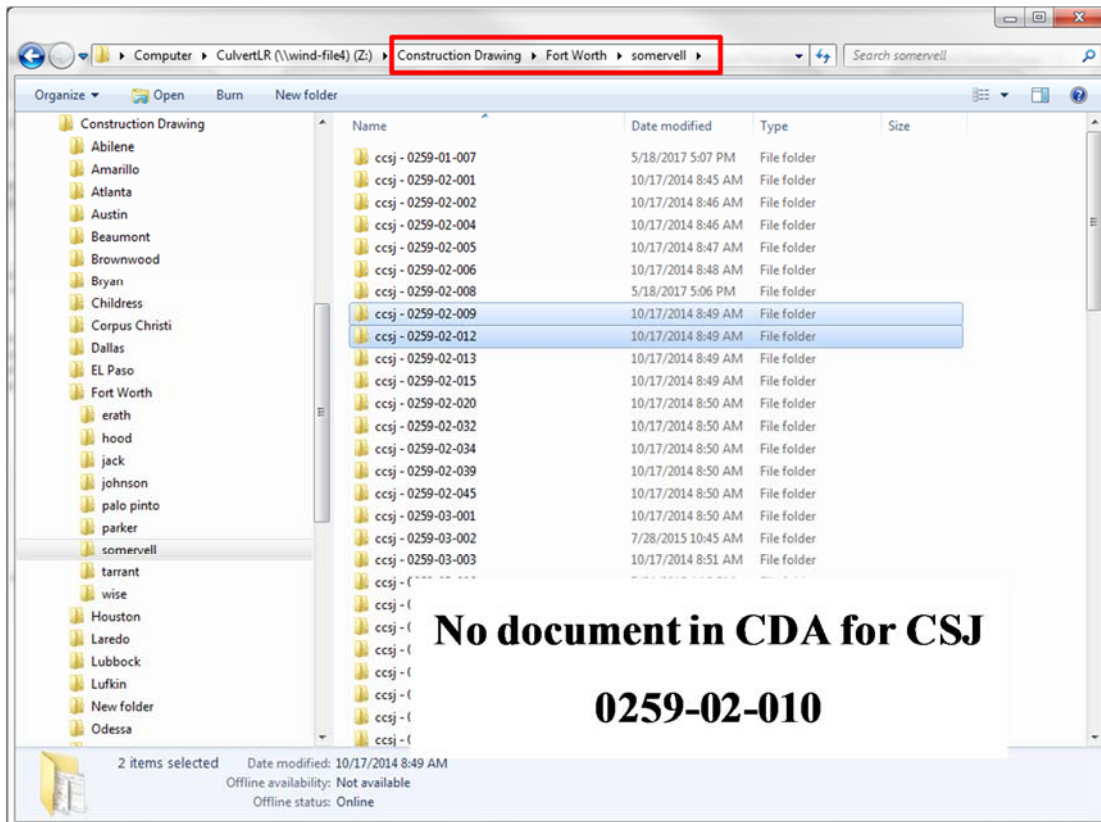

Step 4: Check for additional construction documents using the index card file.

To see whether another CSJ number is associated with the original CSJ, check the index card file. The index card indicates that CSJ 259-1-7 in Erath County is associated with this culvert.

0259-02.pdf - Adobe Acrobat Pro

File Edit View Window Help

Open Create Save Print Mail Settings Help Tools Fill & Sign Comment

1 / 4 92.9%

CARD 1 COUNTY SOMERVELL CONTROL 259 SEC. 2

JOB	PROJECT NO.	FOLDER NO.														YEAR	
		1	2	3	4	5	6	7	8	9	9	9	9	12	1		4
		A	B	C	Y	Z	B	B									
1	SAP 328-B	x	x	x	x		x	x	x								1922
2	SAP 474	x	x	x	x		x	x	x								1924
3	M 2-V-2	x															1929
4	NRS	x	x	x	x	x	x	x									1933
5	SAP 259-2-5	x	x		x	x	x	x									1938
6	F 902 (10)	x	x		x	x	x	x						x	x		1946
7	M 259-2-7	SEE 7-8-7 PALO PINTO COUNTY														1946	
8	C 259-2-8	SEE 79-4-12 ERATH COUNTY														1947	
9	C 259-2-9	x	x		x	x	x	x									1948
10	F 1048 (3)	SEE 259-1-7 ERATH COUNTY														1952	
11	MC 259-2-11	x															1953
12	M 259-2-12	x															1954
13	C 259-2-13	x	x		x	x	x	x									1954
14	M 259-2-14	x															1956

Another CSJ found related to this job

Open the new index card file for CSJ 259-1-7. It shows that no additional CSJ is listed.

0259-01.pdf - Adobe Acrobat Pro

File Edit View Window Help

Open Create Save Print Mail Settings Help Tools Fill & Sign Comment

1 / 3 92.3%

CARD 1 COUNTY ERATH CONTROL 259 SEC. 1

JOB	PROJECT NO.	FOLDER NO.														YEAR	
		1	2	3	4	5	6	7	8	9	9	9	9	12	1		4
		A	B	C	Y	Z	B	B									
1	M 9-R	x															1928
2	M 2-G-3	x															1930
3	S.A.P. 259-1-3	x	x		x	x	x	x									1937
4	S.A.P. 259-1-4						x	x		ALSO SEE 19-2-4 JOHNSON CO.						1942	
5	C 259-1-5	SEE CONTROL 250-7-1 ERATH COUNTY														1947	
6	C 259-1-6	SEE CONTROL 79-4-12 ERATH COUNTY														1947	
7	F 1048 (3)	x	x		x	x	x	x	x					x	x		1952
8	C 259-1-8	x	x		x	x	x	x						x	x		1953
9	C 259-1-9	x	x		x	x	x	x						x	x		1954
10	C 259-1-10																1955
11	M 259-1-11	x															1956

No additional CSJ listed.

With the new CSJ number (259-1-7), search construction drawing archive. A folder is found in CDA for CSJ 0259-01-007.

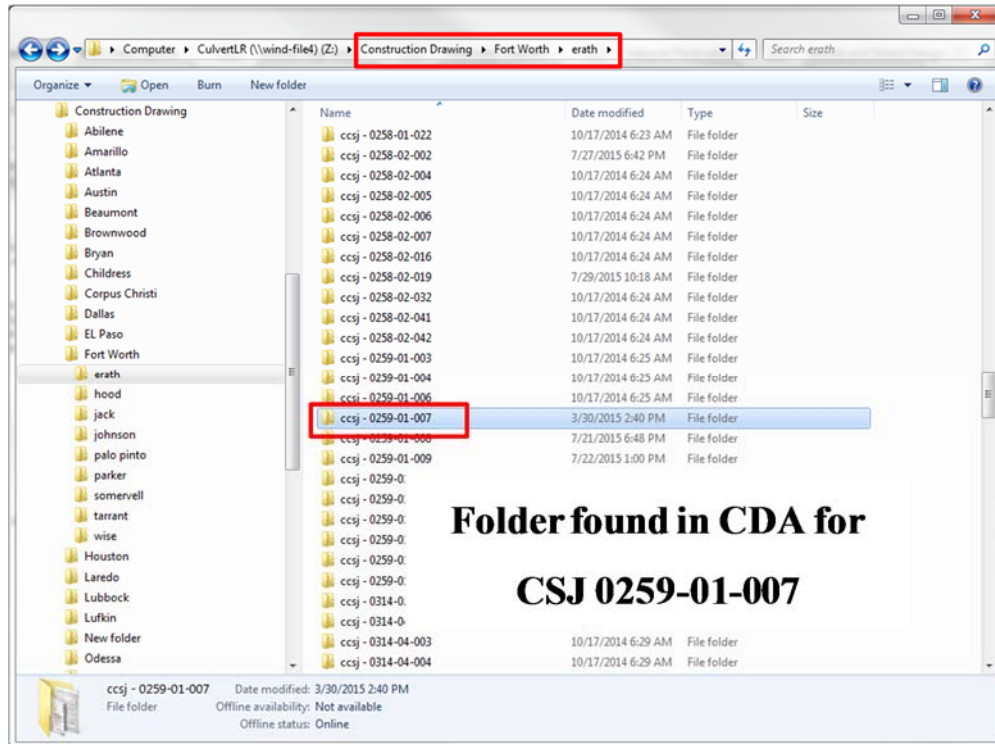

Open the folder and see what is there. A total of 64 drawings are found. Combine each drawing files into a single PDF.

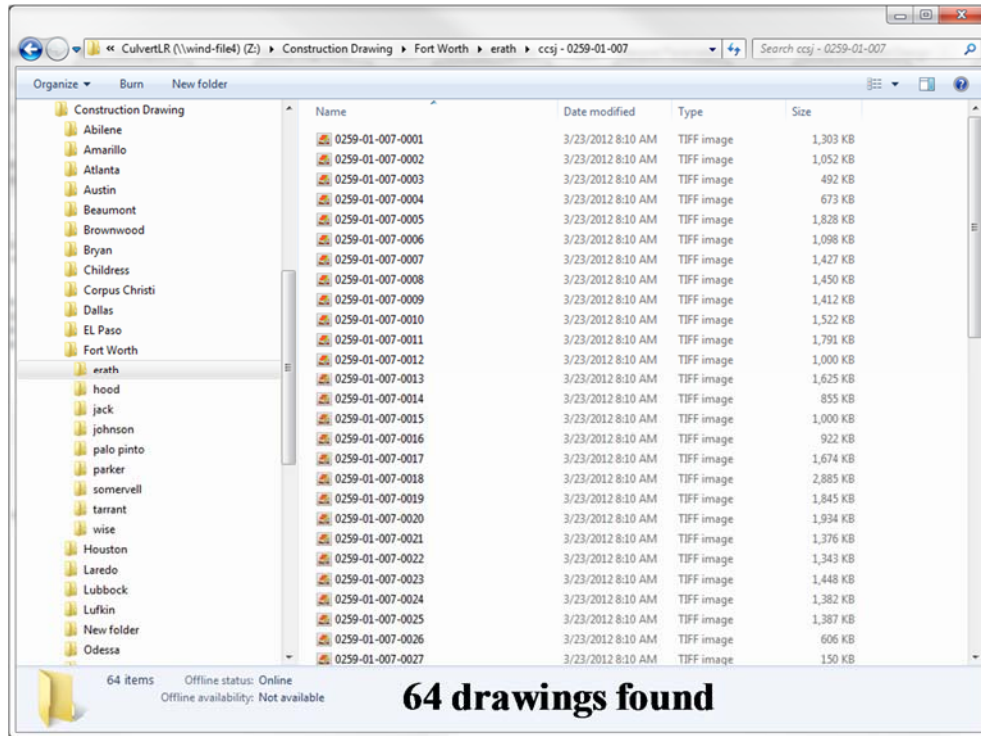

Step 5: Classify and record documents for the culvert.

After reviewing each files, classify and record what types of documents are available for the culvert. Classifications of all the documents available for this culvert are shown below.

Document (File) name	Inventory Record		Drawings			Photos	Inspection Report			
	Inventory Record	Revision	Plan/Profile	Design	Other - Drawings	Photos	Inspection Report	Follow-up	Inspection sketch	Other documents
02-213-0259-02-008_Inspection-2012	x		x	x			x	x		
02-213-0259-02-008_Photos-2012						x				
22130025902008 - Erath 0259-01-007			x	x	x					

The following key documents needed for load rating are captured from this task:

- Inventory Record

- Bridge Inspection Record
- Inspection Photos
- Construction Drawings (from CDA archive with additional CSJ)
- Design Standard

Similar walk-through process for EXAMPLE 1 and EXAMPLE 2 culverts are presented in Module 2 of training materials (Examples 2.1 and 2.2).

APPENDIX B
EXAMPLE
"SEGMENT INTERPRETATION"

Example 3.3

Example 3.3 is about Task 2: Structure History and Segment Interpretations (Module 3 in training materials). We review captured documents from Task 1, study culvert history, and identify segments.

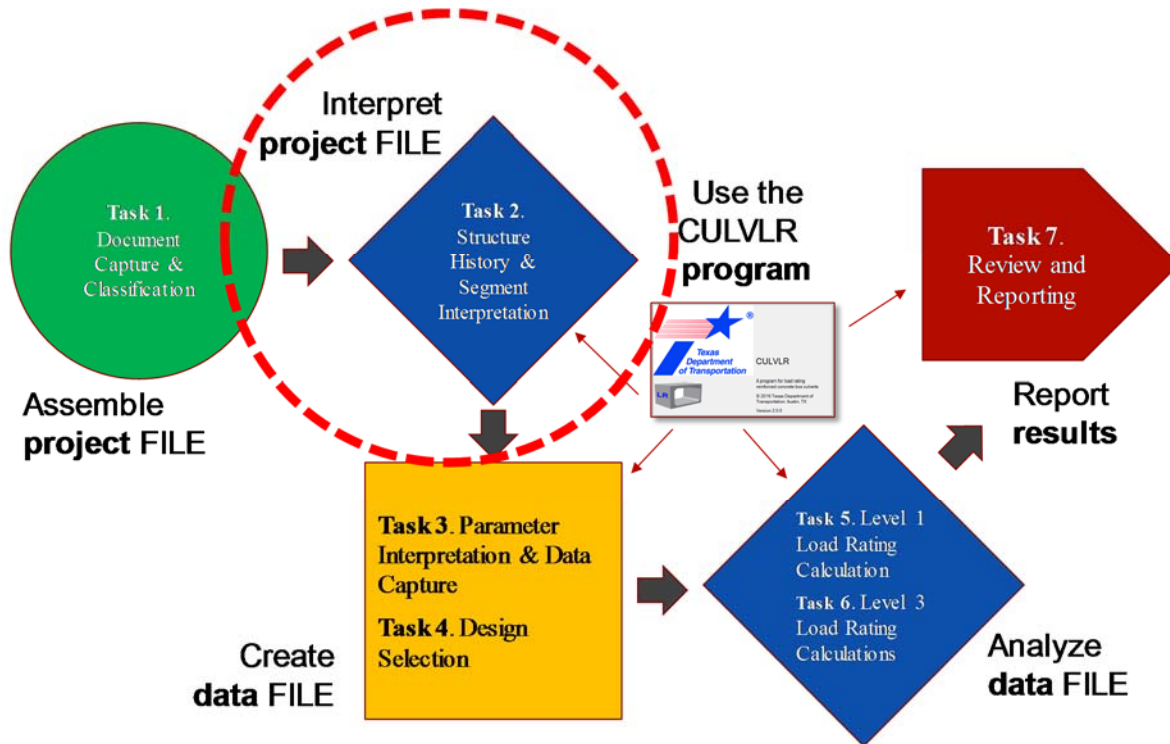

Example 2.3 is a culvert located in Somervell County of Fort Worth District. It carries US 67. Structure number for the culvert is 02-213-0259-02-008 (22130025902008). The objective of Example 2.3 is to review captured documents, study culvert history, and identify segments

Study of culvert history and segment interpretive process are as follows:

- 1) Review captured documents (*from Task 1*).
- 2) Create rational interpretation of segments.
- 3) Draw sketch of interpreted segments.
- 4) Name each segment.
- 5) Annotate source documents.
- 6) Cycle through this process and adjust interpretation to achieve best fit

We use the same culvert used for Example 2.3 for this task.

- Structure Number: 02-213-0259-02-008 (22130025902008)
- District: 02 Fort Worth
- County : 213 Somervell

- Facility carried: US 67

Review of Inventory Record

The following key documents needed for load rating were captured from the Task 1:

- Inventory Record
- Bridge Inspection Record
- Inspection Photos
- Construction Drawings (from CDA archive with additional CSJ)
- Design Standard

We first review key descriptive information for this culvert from Pontex.

- 3-barrel 8x8 culvert on US 67
- Bridge length: 27 ft
- Skew: 0 deg
- Year built: 1925

Now, open Inventory Record and review it. Inventory record confirms descriptive information in Pontex, but it says **the culvert was widened in 1953**. Also, note that ‘Deck Width’ is 57.3 ft.

District: <u>02</u>	County: <u>213</u>	Cont-Sec: <u>0259-02</u>	Structure: <u>008</u>	Route: <u>US 67</u>
Feature Crossed: <u>Woods Branch</u>	Inspector's Signature: <u><i>W. P. ...</i></u>		Date: <u>12/19/2012</u>	
Company Name: <u>Bontempo Structural Engineering, Inc. (F-7708)</u>				
Location: <u>1.2 MI West of FM 203</u>		Maintenance Section: <u>05</u>		
Latitude: <u>N 32° 11' 24.60"</u>	Longitude: <u>W 97° 51' 20.86"</u>	Milepoint: <u>07.124</u>		
General Description:				
<u>3-barrel (8' x 8') concrete box culvert. No approach guardfence is provided. Culvert is on a high speed paved road with a high ADT (~3,900 vpd).</u>				
Bridge Length: <u>27</u> ft.	Deck Width: <u>57.3</u> ft.	Lanes On: <u>02</u>	Lanes Under: <u>00</u>	
Skew Angle: <u>0</u> Deg.	<input type="checkbox"/> Lf. Fwd.	<input type="checkbox"/> Rt. Fwd.	Bridge Rail: <u>None</u>	
Clear Width Between: <u>43</u> ft.	<input type="checkbox"/> Curbs,	<input type="checkbox"/> Rails,	<input checked="" type="checkbox"/> Pvmt Edges	Approach Rdway Wid: <u>43</u> ft.
Deck Type: <u>Concrete</u>				
Surfacing: <u>~2" asphalt</u>		Vertical Over-Clearance: _____ ft. <input checked="" type="checkbox"/> Unimpaired		
Horizontal / Vertical Alignment: <u>Good / Good</u>				
Date Built / Design Load: <u>1925 (Widened in 1953)</u>		<u>Unknown (H 20-44)</u>		
Regulatory / Advisory Speeds: <u>70 mph / None</u>		Original built in 1925; Widened in 1953		
Posted Load Restriction: _____				<input checked="" type="checkbox"/> None

Review of Inspection Photos

Reviewing photos confirm that the culvert has three barrels.



ELEVATION

Looking North

Review of Construction Drawings

Now, open construction drawings and review them. CJS numbers listed on the cover page match with the CSJs identified from Task 1. The cover page says the final plans are for the work began in 1952 and completed in 1953; this indicates the drawing sets are for widening project.

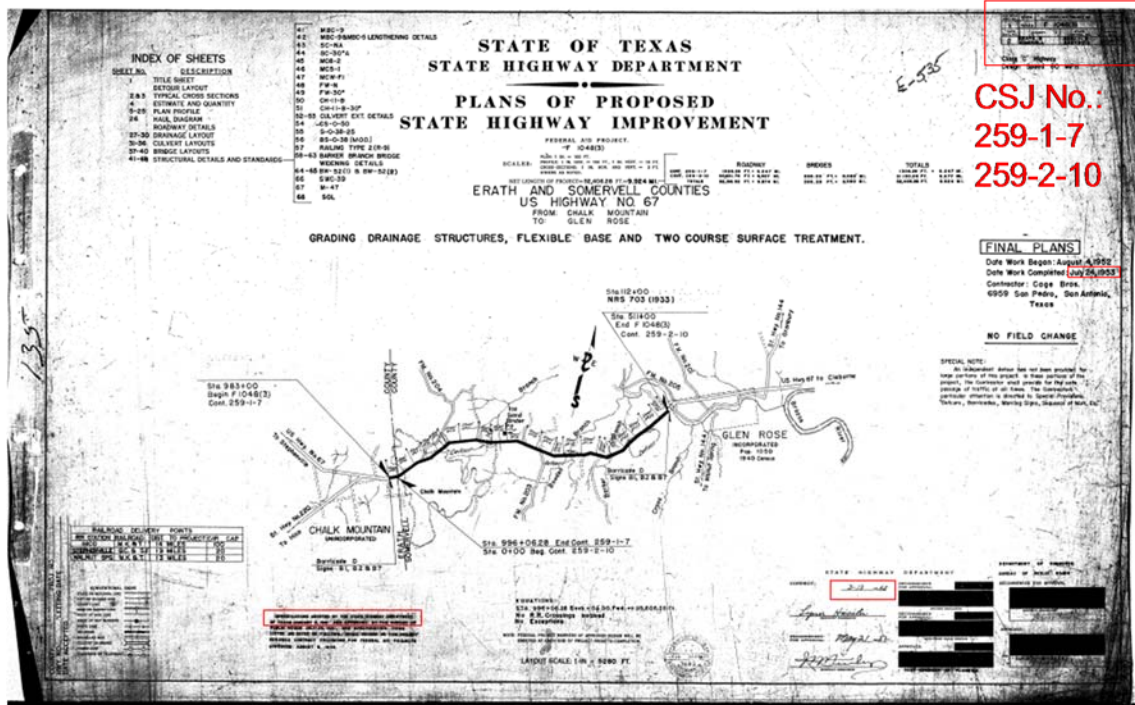

Summary of Bridges provides various information for bridges with permanent structure number such drawing sheet numbers for plan & profile view, stations, length, and design, etc. Look for **Permanent Structure No. 8** (recall the structure number: 02-213-0259-02-008). The following information, among others, is obtained for Permanent Structure No. 8:

- Sheet No. for Plan & Profile: 14
- Sheet No. for Layout: 38
- Beginning Station: 201+42.30
- End Station: 201+69.30
- Length: 27 ft
- Design: MC8-2 & MCW-F1

The drawing for plan and profile views on Sheet No. 14 provides the following information:

Existing culvert

- Size: 3-8x8

- Width (or flowline length): 27.97 ft

Proposed culvert

- Size: 3-8x6
- Proposed widening: Extension of 14.11 ft to the left
- Proposed widening: Extension of 13.92 ft to the right
- Design standard for the widening segment: MC8-2

The layout drawing on Sheet No. 38 presents the existing original segment in a dashed line and the proposed widened segment in a solid line.

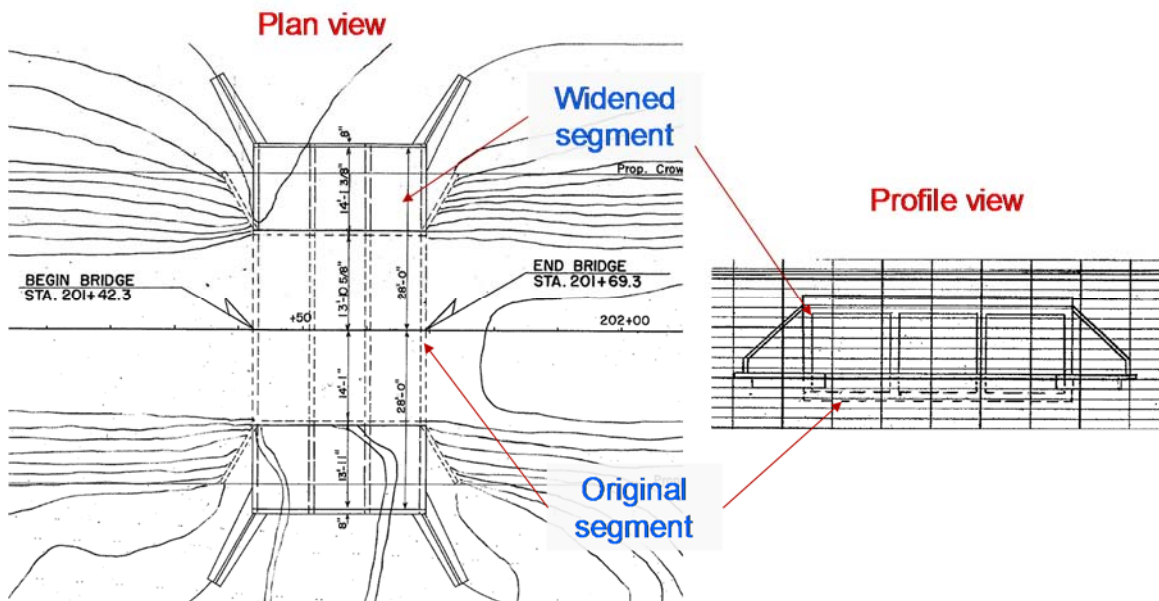

Creation of Segment Sketch

All the gathered information suggest that this culvert is consisted of two segments. Now, draw segment sketch, name the segments, and annotate source documents as follows:

- Segment 1 Name: 1 Org 1925 3-8x8 T
- Segment 1 geometry: 3-barrel 8'x8'
- Segment 1 Built year: 1925 (original)
- Skew: 0 degree
- Segment 2 Name: 2 Wid 1953 3-8x6 T
- Segment 2 geometry: 3-barrel 8'x6'
- Segment 2 Built year: 1953 (widened)
- Skew: 0 degree

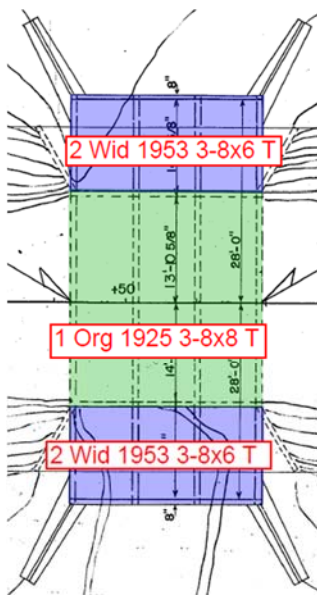

Plan View

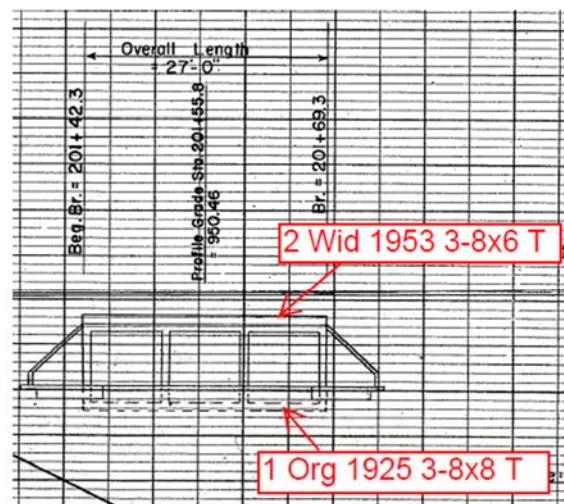

Elevation View

The following additional examples on Structure History and Segment Identification can be found in Module 3 of the training materials:

- EXAMPLE 1: 01-075-0279-04-013 (Example 3.1)
- EXAMPLE 2: 01-081-2731-02-001 (Example 3.2)

APPENDIX C

EXAMPLE

"PARAMETER INTERPRETATION AND DATA CAPTURE"

Example 4.3

Example 4.3 is about Task 3: Parameter Interpretations and Data Capture (Module 4 in training materials). Objective of Task 3 is to evaluate each document, and determine single, complete, un-conflicted dataset required for load rating for each segment.

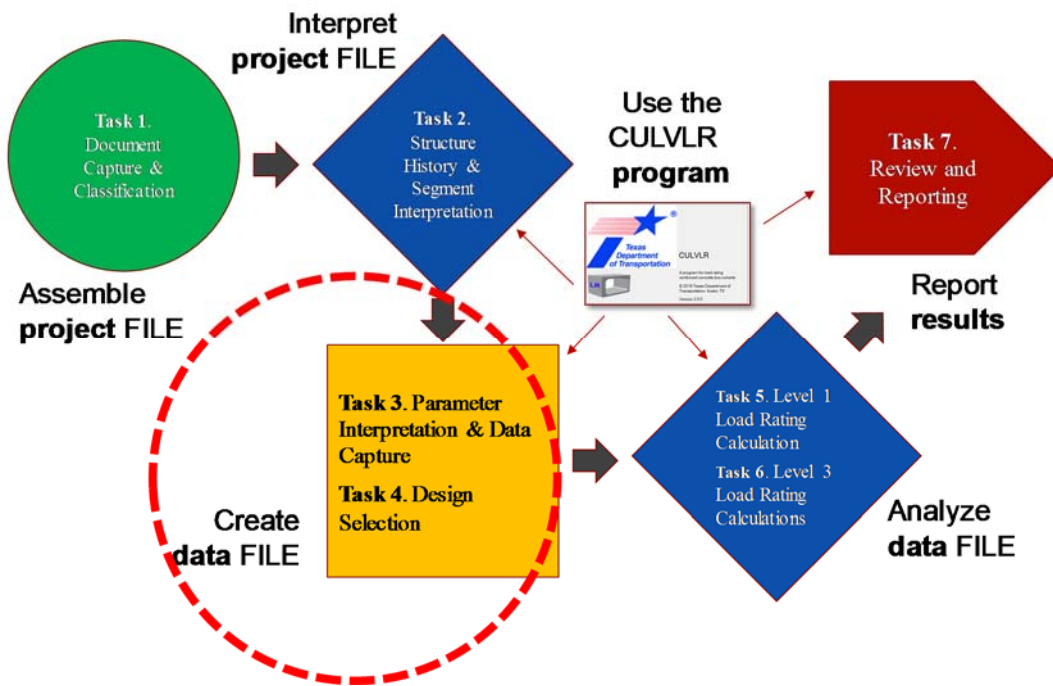

Segment interpretation and basic segment data for this culvert obtained from previous tasks are as follows:

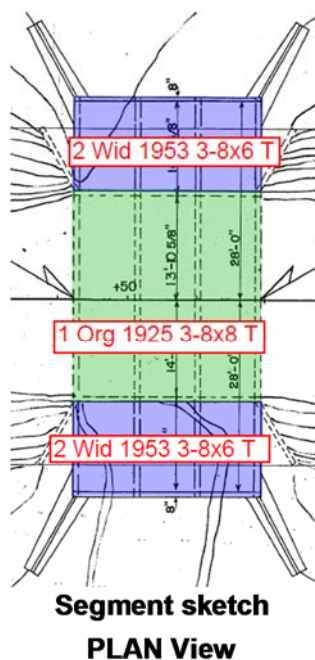

Interpreted segments

- Number of segment: 2
- Segment 1 Name: 1 Org 1925 3-8x8 T
- Segment 1 geometry: 3-barrel 8’x8’
- Segment 1 Built year: 1925
- Skew: 0 deg.
- Segment 2 Name: 2 Wid 1953 3-8x6 T
- Segment 2 geometry: 3-barrel 8’x6’
- Segment 2 Built year: 1953
- Skew: 0 deg.



Data Capture from Inventory Record

Now, open Inventory Record and capture data. In addition to the Pontex data, Inventory Record provides additional information about pavement surface: 2" asphalt.

District: <u>02</u>	County: <u>213</u>	Cont-Sec: <u>0259-02</u>	Structure: <u>008</u>	Route: <u>US 67</u>
Feature Crossed: <u>Woods Branch</u>	Inspector's Signature: <u><i>W. P. ...</i></u>		Date: <u>12/19/2012</u>	
Company Name: <u>Bontempo Structural Engineering, Inc. (F-7708)</u>				
Location: <u>1.2 MI West of FM 203</u>			Maintenance Section: <u>05</u>	
Latitude: <u>N 32° 11' 24.60"</u>	Longitude: <u>W 97° 51' 20.86"</u>	Milepoint: <u>07.124</u>		
General Description: <u>3-barrel (8' x 8') concrete box culvert. No approach guardfence is provided. Culvert is on a high speed paved road with a high ADT (~3,900 vpd).</u>				
Bridge Length: <u>27</u>	Skew angle: 0 deg.		Lanes On: <u>02</u>	Lanes Under: <u>00</u>
Skew Angle: <u>0</u> Deg.	<input type="checkbox"/> Lf. Fwd.	<input type="checkbox"/> Rt. Fwd.	Bridge Rail: <u>None</u>	
Clear Width Between: <u>43</u> ft.	<input type="checkbox"/> Curbs,	<input type="checkbox"/> Rails,	<input checked="" type="checkbox"/> Pvmt Edges	Approach Rdway Wid: <u>43</u> ft.
Deck Type: <u>Concrete</u>				
Surfacing: <u>~2" asphalt</u>	Vertical Over-Clearance: _____ ft.		<input checked="" type="checkbox"/> Unimpaired	
Pavement surface: asphalt				
Horizontal / Vertical Alignment: <u>Good / Good</u>				
Date Built / Design Load: <u>1925 (Widened in 1953) / Unknown (H 20-44)</u>				
Regulatory / Advisory Speeds: <u>70 mph / None</u>				
Posted Load Restriction: _____				<input checked="" type="checkbox"/> None

Data Capture from Photos

Inspection photo confirms the asphalt surface. PMIS data classify the pavement as 4 Thick ACP (> 5in).



DATE: 19 DEC 2012
 COUNTY: 213
 CONT-SEC: 0259-02
 STR: 008

ROADWAY OVER BRIDGE

Looking East

PMIS Pavement: 4 Thick ACP (>5in.)

Photos further suggest that the widened segment is not haunched. It is unclear from the photo whether or not the original segment is haunched. A rough estimation of cover soil depth (about 3 to 4 ft) can be also obtained. Data from photos are as follows:

- Span Numbers: 3
- Haunch: Not haunched (widened segment); unclear for original segment
- Cover soil depth: 3 to 4 ft (note that this is rough estimation because camera angle may distort the actual configuration)



ELEVATION

Looking North

Data Capture from Construction Drawings

Summary of Bridges in construction drawing provides the design name for the widened segment: MC8-2.

SUMMARY OF BRIDGES

Per. Str. No.	Sheet No.	Stations			Length	Design	Description	Uncl. Str. Exc. Br. C.Y.	24" Drilled Shafts L.F.	Class 'A' Conc. Slabs C.Y.	Class 'A' Conc. Abut. & Bents. C.Y.	Class 'A' Conc. for Ext. Strs. Slabs. C.Y.	Class 'A' Conc. for Ext. Strs. Abut. & Bents. C.Y.
		Plan & Profile	Layout	Beg.									
51	12	37	176+89.00	177+89.00	100'-0"	CS-0-50	2-50' Conc. Slabs	115	114.8	172.8	75.5		
8	13	38	201+42.30	201+69.30	27'-0"	MC8-2	Conc. Box Ext.						
52	18	39	322+15.00	322+90.00	75'-0"	S-0-30	3-25' Conc. Slabs	54	85.8	147.9	52.7		
10	20	40	386+01.24	386+67.50	66'-3 1/4"	Special	3-28' Slab Exts	182				97.59	113.10
Totals								351	200.6	320.7	128.2	97.59	113.10

Design name for widened segment : MC8-2

Call-out box in the plan and profile view further confirm the design name for widened segment.

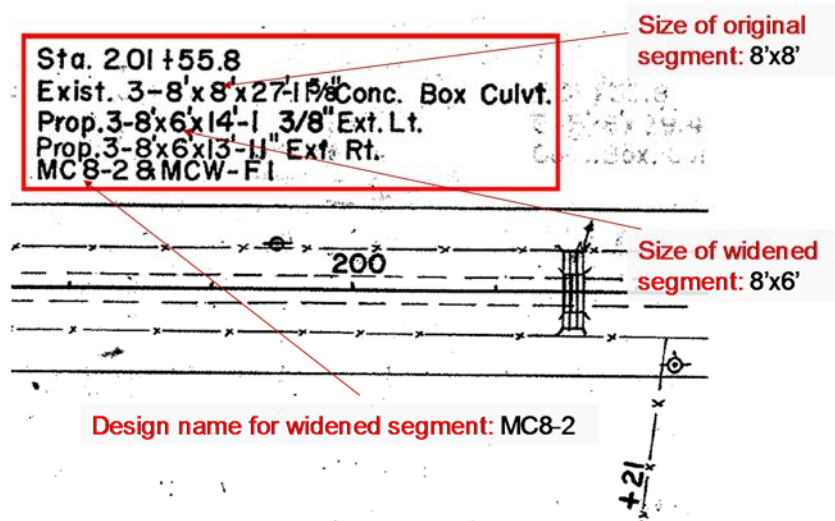

Profile view confirms no haunches, and cover soil depth was determined to be about 4.5 ft using scale in the drawing.

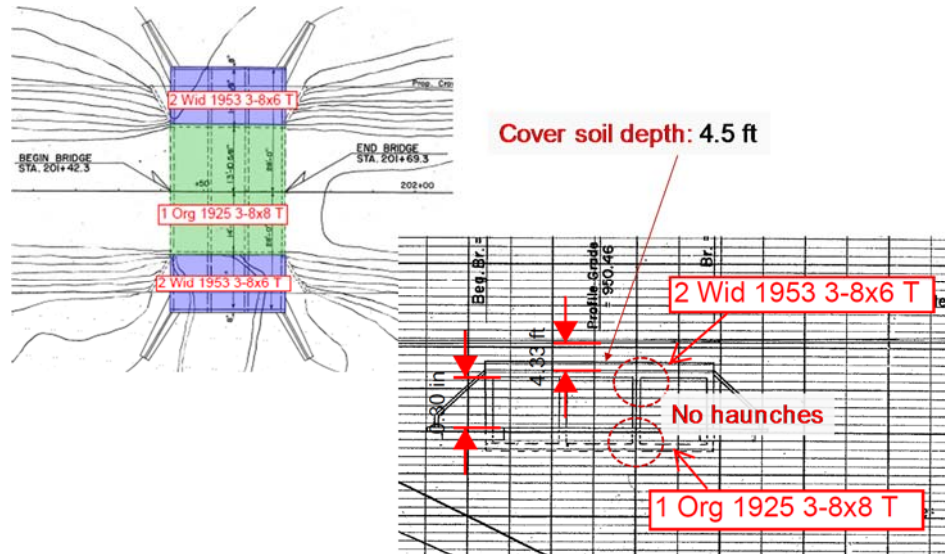

Data Capture from Design Standard

Attached design standard in the construction drawing is MC8-2. Section view confirms no haunch. Further, design original year is 1949 and no revision year is provided.

Provided design: MC8-2

MARK	NO.	DESCRIPTION	DATE	BY	CHECKED	APPROVED
1	1	DESIGNED	1949			
2	1	REVISED				
3	1	REVISED				
4	1	REVISED				
5	1	REVISED				
6	1	REVISED				
7	1	REVISED				
8	1	REVISED				
9	1	REVISED				
10	1	REVISED				
11	1	REVISED				
12	1	REVISED				
13	1	REVISED				
14	1	REVISED				
15	1	REVISED				
16	1	REVISED				
17	1	REVISED				
18	1	REVISED				
19	1	REVISED				
20	1	REVISED				
21	1	REVISED				
22	1	REVISED				
23	1	REVISED				
24	1	REVISED				
25	1	REVISED				
26	1	REVISED				
27	1	REVISED				
28	1	REVISED				
29	1	REVISED				
30	1	REVISED				
31	1	REVISED				
32	1	REVISED				
33	1	REVISED				
34	1	REVISED				
35	1	REVISED				
36	1	REVISED				
37	1	REVISED				
38	1	REVISED				
39	1	REVISED				
40	1	REVISED				
41	1	REVISED				
42	1	REVISED				
43	1	REVISED				
44	1	REVISED				
45	1	REVISED				
46	1	REVISED				
47	1	REVISED				
48	1	REVISED				
49	1	REVISED				
50	1	REVISED				
51	1	REVISED				
52	1	REVISED				
53	1	REVISED				
54	1	REVISED				
55	1	REVISED				
56	1	REVISED				
57	1	REVISED				
58	1	REVISED				
59	1	REVISED				
60	1	REVISED				
61	1	REVISED				
62	1	REVISED				
63	1	REVISED				
64	1	REVISED				
65	1	REVISED				
66	1	REVISED				
67	1	REVISED				
68	1	REVISED				
69	1	REVISED				
70	1	REVISED				
71	1	REVISED				
72	1	REVISED				
73	1	REVISED				
74	1	REVISED				
75	1	REVISED				
76	1	REVISED				
77	1	REVISED				
78	1	REVISED				
79	1	REVISED				
80	1	REVISED				
81	1	REVISED				
82	1	REVISED				
83	1	REVISED				
84	1	REVISED				
85	1	REVISED				
86	1	REVISED				
87	1	REVISED				
88	1	REVISED				
89	1	REVISED				
90	1	REVISED				
91	1	REVISED				
92	1	REVISED				
93	1	REVISED				
94	1	REVISED				
95	1	REVISED				
96	1	REVISED				
97	1	REVISED				
98	1	REVISED				
99	1	REVISED				
100	1	REVISED				

TEXAS HIGHWAY DEPARTMENT
MULTIPLE BOX CULVERTS
 SIZES 8'x4', 8'x5', 8'x6', 8'x7' & 8'x8'
 2'-1" TO 4'-0" FILL
MC8-2

DESIGN ORIGINAL YEAR	1949
STATE	TEXAS
FEDERAL AID PROJECT NO.	F1048(3)
COUNTY	Somervell
SECTION	259
JOB NO.	10 US67

Design Original Year: 1949

No haunches

TEXAS HIGHWAY DEPARTMENT
MULTIPLE BOX CULVERTS
 SIZES 8'x4', 8'x5', 8'x6', 8'x7' & 8'x8'
 2'-1" TO 4'-0" FILL
MC8-2

Data Capture from Web Soil Survey

Web soil survey (WSS) data indicates that the culvert is within the boundary of soil type '46', which is dominantly CL material. The soil stiffness for the CL material is classified as 'medium' per Culvert Rating Guide.



TABLE IV-3. MODULUS OF ELASTICITY FOR SOIL FOR LEVEL 3 MODEL.

Soil Support Description	Elastic Modulus E_{soil} (psi)	Unified Soil Classification (ASTM D2487)	AASHTO Group Classification (AASHTO M 145)	Texas Triaxial Classification (TEX-117-E)
Low: Fine-grained soils in which highly-plastic silt and clay-sized particles predominate	Range: 2,500-25,000+ Typical: 8,000	CH, OH, MH, OL	A5, A6, A7, A8	> 5.0
Medium: Sands and sand-gravel mixtures with moderate amounts of silts and clay	Range: 5,000-50,000+ Typical: 20,000	CL, ML, SC, SP, SM	A3, A4	3.5 to 5.0
High: Gravels and sand-gravel mixtures relatively free of plastic fines	Range: 10,000-70,000+ Typical: 36,000	GW, GP, GM, GC, SW	A1, A2	< 3.5

(NAVFAC, 1986; VanTil, 1972; Coduto, 2001; Bowles, 1996)

Soil stiffness: Medium

				Medium, Silty Clay	CL	
46—Sunev clay loam, 3 to 5 percent slopes						
Sunev	100	B	0-12	Clay loam	CH, CL	A-6, A-7-6
			12-42	Loam, clay loam, silty clay loam	CL	A-4, A-6
			42-62	Loam, clay loam, silty clay loam	CL	A-4, A-6, A-7-6

Captured Data for Segment 1

Summary of captured data for Segment 1 from various sources are as follows:

Captured data for 1 Org 1925 3-8x8 T

Parameters	Sources				
	Inventory Record	Photo	Drawings	WSS	PMIS
Number of spans	3	3	3		
Span length (ft)	8		8		
Box height (ft)	8		8		
Year built	1925				
Skew (deg.)	0		0		
Haunch?		Unclear	No		
Cover soil depth: min. (ft)		3	4.5		
Cover soil depth: max. (ft)		3	4.5		
Design Sheet Name					
Design Original year					
Design revision year					
Pavement type	Asphalt	Asphalt			4 Thick ACP
Soil type stiffness				Medium	

Final un-conflicted dataset required for load rating for Segment 1 is as follows:

- Segment 1 Name: 1 Org 1925 3-8x8 T
- Number of spans: 3
- Span length: 8 ft
- Box height: 8 ft
- Year built: 1925
- Skew: 0 degree
- Haunch?: Unclear
- Minimum cover soil depth: 3 ft
- Maximum cover soil depth: 4.5 ft
- Design sheet name: N/A
- Design original year: N/A
- Design revision year: N/A
- Pavement type: 4 Thick ACP
- Soil stiffness: Medium

Captured Data for Segment 2

Summary of captured data for Segment 2 from various sources are as follows:

Captured data for 2 Wid 1953 3-8x6 T

Parameters	Sources				
	Inventory Record	Photo	Drawings	WSS	PMIS
Number of spans	3	3	3		
Span length (ft)	8		8		
Box height (ft)	8		6		
Year built	1953				
Skew (deg.)	0		0		
Haunch?		No	No		
Cover soil depth: min. (ft)		3	4.5		
Cover soil depth: max. (ft)		3	4.5		
Design Sheet Name			MC8-2		
Design Original year			1949		
Design revision year					
Pavement type	Asphalt	Asphalt			4 Thick ACP
Soil type stiffness				Medium	

Final un-conflicted dataset required for load rating for Segment 2 is as follows:

- Segment 2 Name: 2 Org 1953 3-8x6 T
- Number of spans: 3
- Span length: 8 ft
- Box height: 6 ft
- Year built: 1953
- Skew: 0 degree
- Haunch?: Unclear
- Minimum cover soil depth: 3 ft
- Maximum cover soil depth: 4.5 ft
- Design sheet name: MC8-2
- Design original year: 1939
- Design revision year: N/A
- Pavement type: 4 Thick ACP
- Soil stiffness: Medium

The following additional examples on Data Capture and Parameter Interpretation can be found in Module 4 of the training materials:

- EXAMPLE 1: 01-075-0279-04-013 (Example 4.1)
- EXAMPLE 2: 01-081-2731-02-001 (Example 4.2)
- EXAMPLE 4: 02-182-0391-08-046 (Example 4.4)

APPENDIX D
EXAMPLE
"DESIGN SELECTION"

Example 5.3

Example 5.3 is about Task 4: Design Selection (Module 5 in training materials). Objective of Task 4 is to select design for each segment using the given segment data.

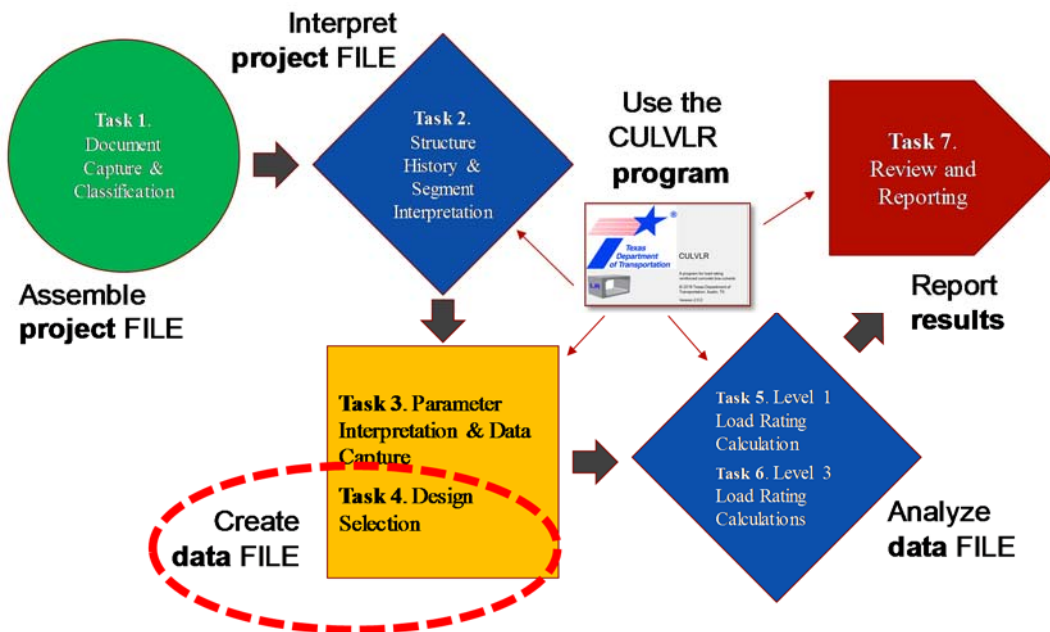

From previous tasks, segment interpretation and data capture has been completed as follows:

Segment 1:

- Name: 1 Org 1925 3-8x8 T
- Number of spans: 3
- Span length: 8 ft
- Box height: 8 ft
- Year built: 1925
- Skew: 0 degree
- Haunch?: Unclear
- Minimum cover soil depth: 3 ft
- Maximum cover soil depth: 4.5 ft
- Selected cover soil depth: 4 ft
- Design sheet name: N/A
- Design original year: N/A
- Design revision year: N/A

- Pavement type: 4 Thick ACP
- Soil stiffness: Medium

Segment 2:

- Name: 2 Org 1953 3-8x6 T
- Number of spans: 3
- Span length: 8 ft
- Box height: 6 ft
- Year built: 1953
- Skew: 0 degree
- Haunch?: Unclear
- Minimum cover soil depth: 3 ft
- Maximum cover soil depth: 4.5 ft
- Selected cover soil depth: 4.5 ft
- Design sheet name: MC8-2
- Design original year: 1939
- Design revision year: N/A
- Pavement type: 4 Thick ACP
- Soil stiffness: Medium

Design Selection for Segment 1

Recall from the previous example that the Design standard for Segment 1 was neither provided nor specified. Therefore, one design that matches the segment data need to be associated.

Design for Segment 1 was neither provided nor specified.

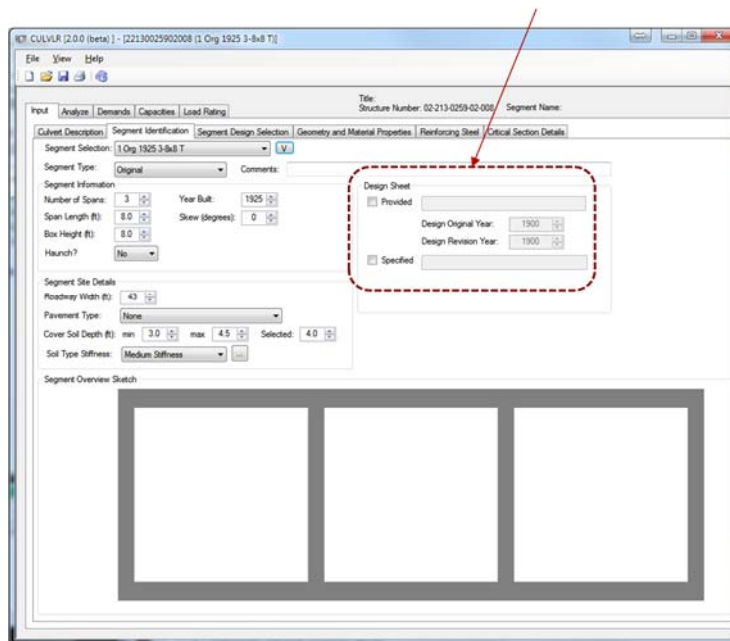

Click “Segment Design Selection” Tab. Then, click “Refresh Design List.” Five designs (three standard designs and two special designs) show up. Select MBC-8-1924.

Click “Segment Design Selection” Tab. Then, click “Refresh Design List.” Five designs (three standard designs and two special designs) show up. MBC-8-1924 is selected.

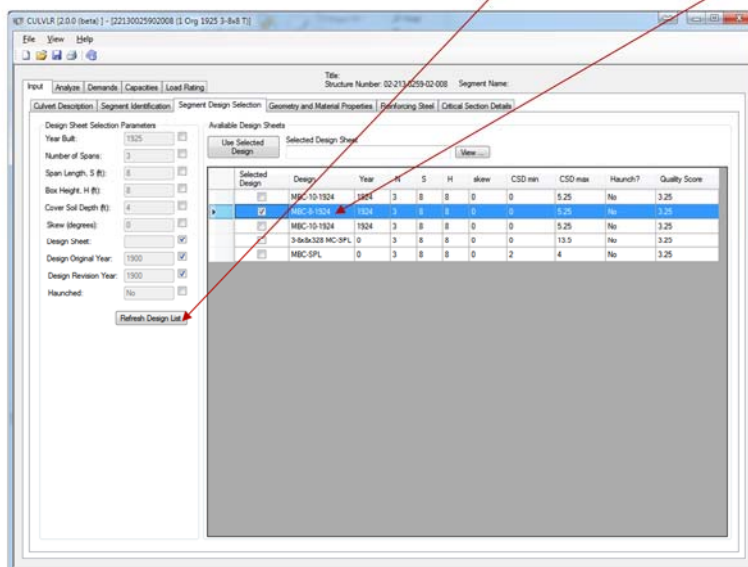

Click “Use Selected Design.” The selected design will appear in the “Selected Design Sheet” text box. This completes the design selection for Segment 1. Rebar configuration associated with the selected design sheet will be used to compute capacities at each critical section for load rating analysis.

Click “Use Selected Design.” The selected design will appear in the “Selected Design Sheet” text box.

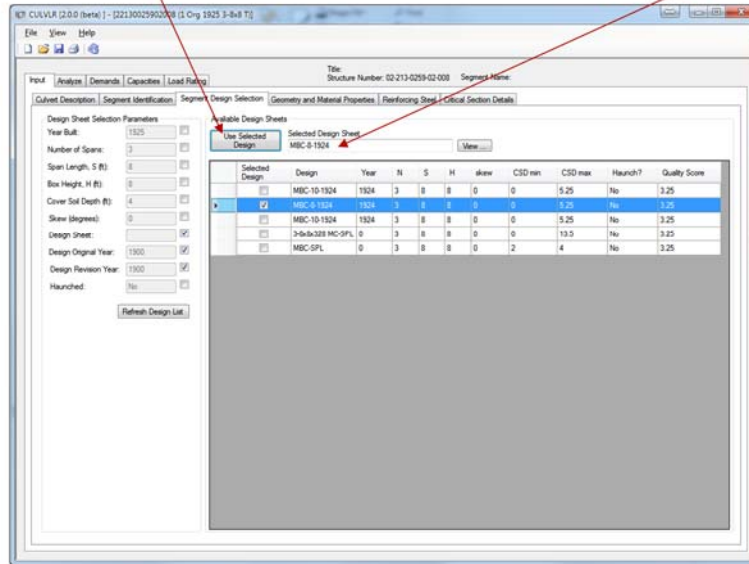

Design Selection for Segment 2

Now, open *.clrp file for Segment 2. Recall that design standard for Segment 2 was provided (MC8-2). Therefore, MC8-2 must be selected for Segment 2.

Design for Segment 2 was provided. Therefore, we need to select the provided design (MC8-2).

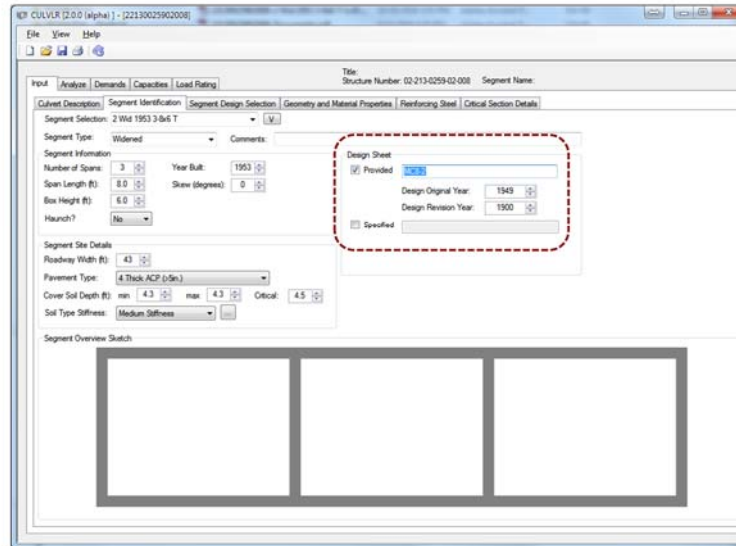

Click “Segment Design Selection” Tab. Then, click “Refresh Design List.” No design shows up. This is because the selected cover soil depth of 4.5 ft for Segment 2 is outside the cover soil depth range for MC8-2.

Click “Segment Design Selection” Tab. Then, click “Refresh Design List.” No design shows up. This is because the selected cover soil depth of 4.5 ft is outside the cover soil depth range for MC8-2.

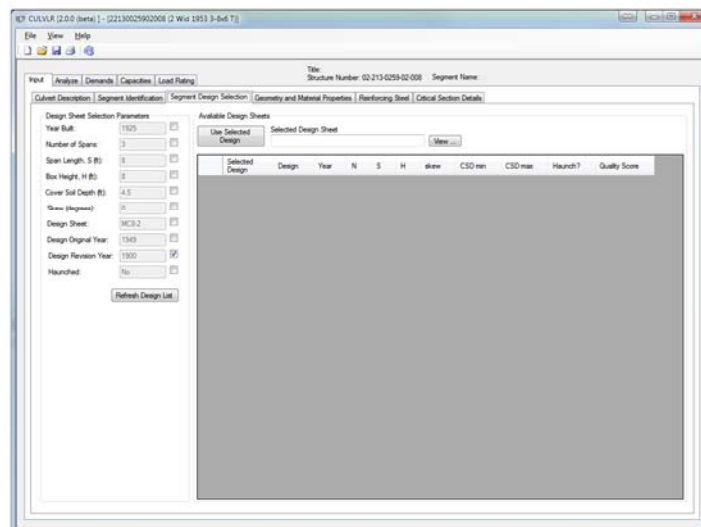

Check “Cover Soil Depth” to ignore this variable during filtering process and click “Refresh Design List.” The MC8-2-1949 shows up. Click “Use Selected Design.”

Check “Cover Soil Depth” to ignore this variable during filtering process and click “Refresh Design List.” The MC8-2-1949 shows up. Click “Use Selected Design.”

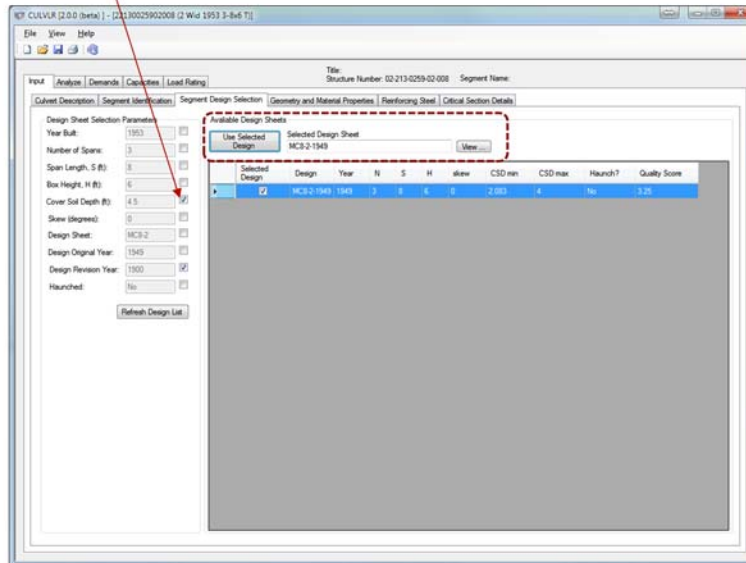

The following additional examples on Design Selection can be found in Module 5 of the training materials:

- EXAMPLE 1: 01-075-0279-04-013 (Example 5.1)
- EXAMPLE 2: 01-081-2731-02-001 (Example 5.2)
- EXAMPLE 4: 02-182-0391-08-046 (Example 5.4)

APPENDIX E
EXAMPLE
"LEVEL 1 AND LEVEL 3 LOAD RATING"

Example 6.3

Example 6.3 is about Tasks 5 and 6: Level 1 and Level 3 Load Rating Calculations (Module 6 in training materials). Objective of Tasks 5 and 6 is to perform Level 1 and Level 3 analyses and obtain IRF and ORF values using captured data and selected design.

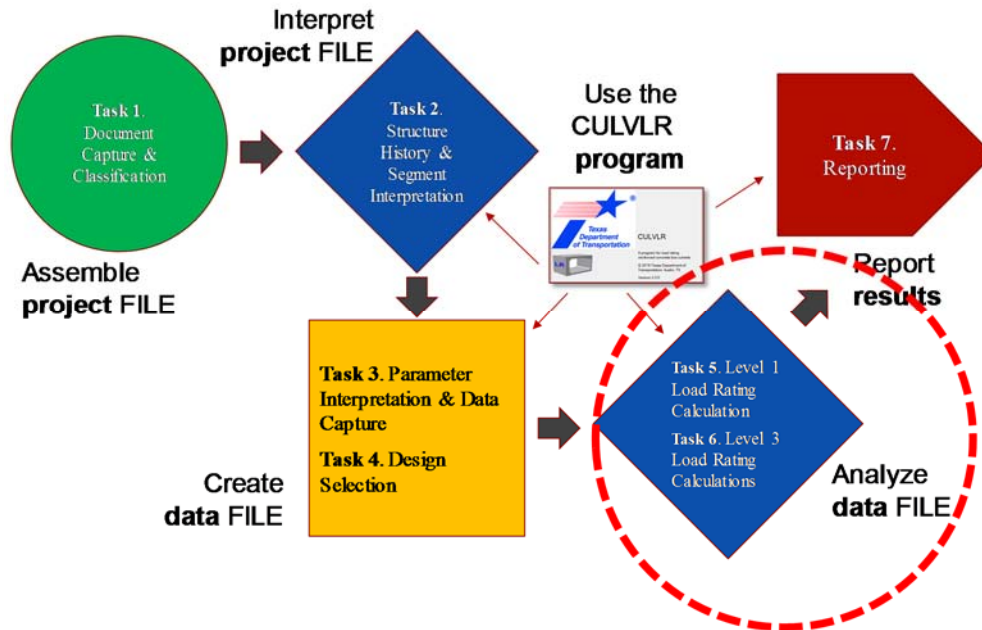

Selected design and captured data for Segment 1 were entered into CulvLR 2.0 in previous examples as follows:

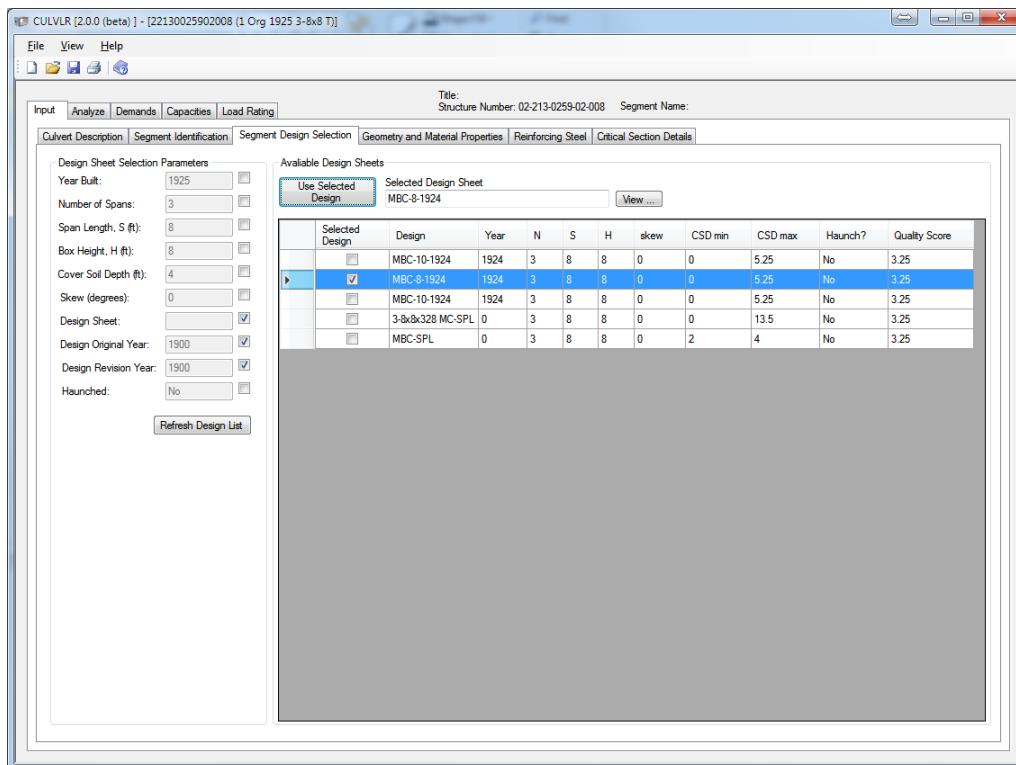

Level 1 Analysis for Segment 1

To perform Level 1 load rating analysis, click “Analyze” tab and make sure analysis level is “Level 1 – Structural Frame Model – CULV-5.” Then, select “TxDOT Practice” from Soil Properties Type dropdown menu.

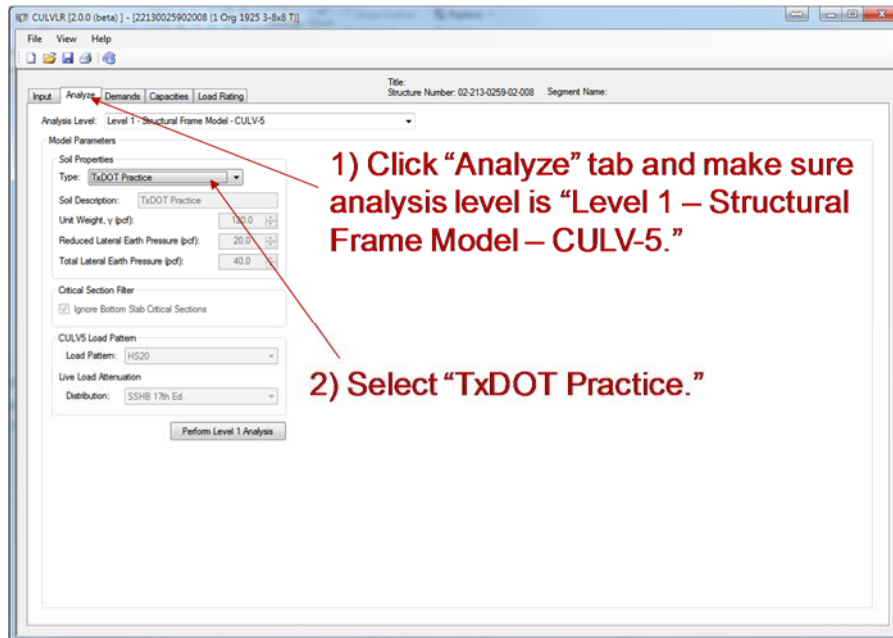

Click “Perform Level 1 Analysis” button. CulVLR 2.0 uses CULV5 behind the scene to perform the demand calculation using the structural frame model. After analysis is completed, a pop-up window will appear. Click Yes.

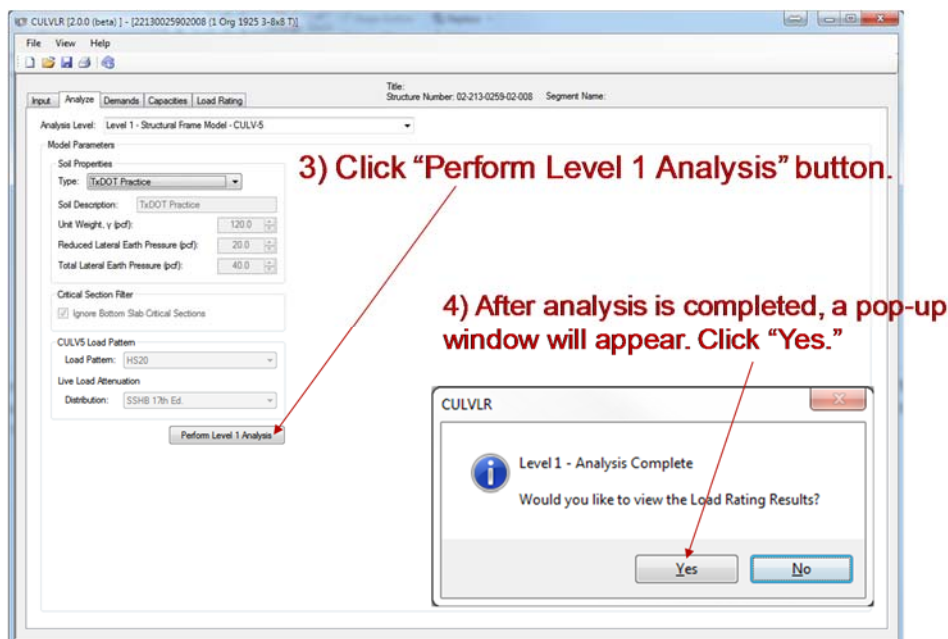

Clicking “Yes” will take you to “Load Rating” tab. Clicking the “View Critical Section Sketch” button will generate a color coded culvert sketch highlighting the controlling critical sections.

5) It will take you to “Load Rating” tab. Review results.

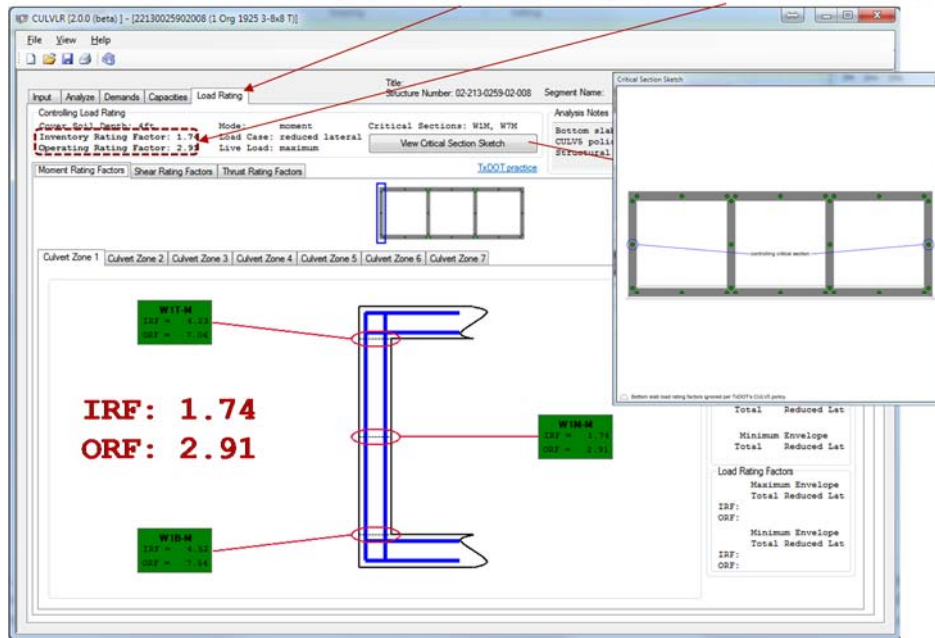

The color codes are based on TxDOT’s load posting chart which can be viewed by clicking the “View Color Code Key” button.

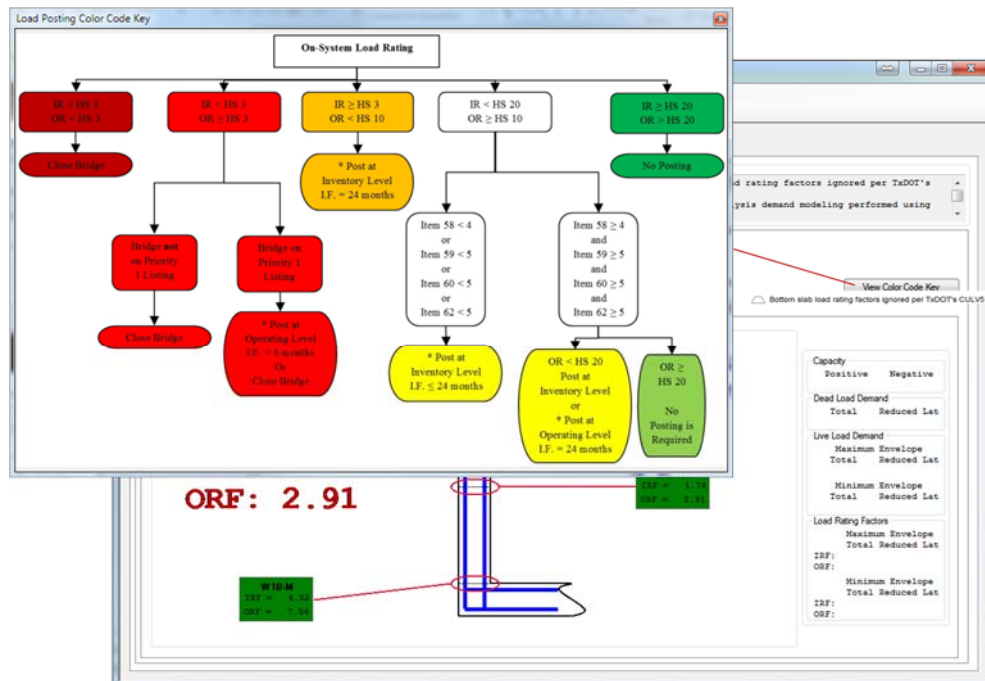

Level 3 Analysis for Segment 1

CulvLR2.0 requires demand analysis for dead and live loads to be performed in RISA-3D and therefore interacts with RISA-3D. The figure below shows a flowchart for Level 3 analysis in CulvLR2.0. The light-red boxes in the flowchart indicates the tasks done in CulvLR2.0 and tasks in blue boxes are carried out in RISA-3D.

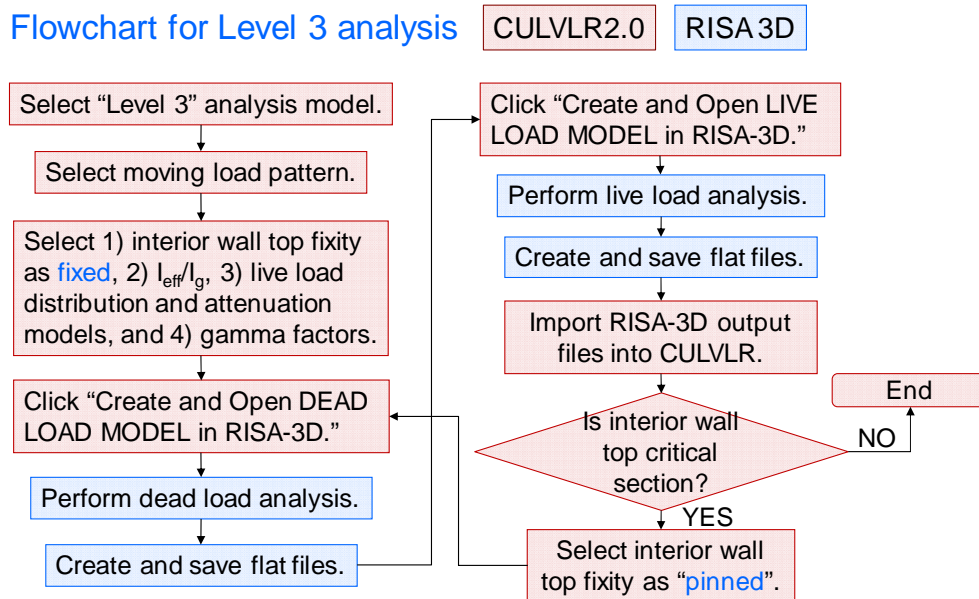

Dead load analysis

After finishing Level 1 load rating, go back to “Analyze” tab and select “Level 3 – Soil-Structure Interaction Model – RISA-3D.” Then, select moving load pattern. In this example, HS20 (v=14’) is selected. Make sure the default run environments are set as follows:

- Interior Wall Top Fixity: “Fixed”
- Effect Moment of Inertia: “Recommended ($I_{eff}/I_g = 0.5$ for flexural members and 1.0 for axial members)”
- Live Load Distribution: “LRFD 7th Ed.”
- Live Load Attenuation Method: “Section Depth Calibrated”
- Gamma Factors: “Recommended”

Demand analyses for dead and live loads are performed separately. Now, click “Create and Open DEAD LOAD MODEL in RISA-3D” button.

Level 3 analysis – Dead Load

1) Go back to “Analyze” tab and select “Level 3 – Soil Structure Interaction Model – RISA-3D.”

2b) Make sure your default run environments are correct:

- Interior Wall Top Fixity: “Fixed”
- Effect Moment of Inertia: “Recommended”
- Live Load Distribution: “LRFD 7th Ed.”
- Live Load Attenuation Method: “Section Depth Calibrated”
- Gamma Factors: “Recommended”

2a) Select moving load pattern.

3) Click “Create and Open DEAD LOAD MODEL in RISA-3D.”

In addition to HS20, various moving load patterns can be selected. For example, the following load pattern appears if “SU5 Truck” is selected:

Level 3 analysis – Dead Load

Various moving load patterns can be selected. For example, the following load pattern appears if “SU5 Truck” is selected:

[Wheel Loads] Magnitude (k)	Direction	Distance (ft)
-6	Y	0
-4	Y	10
-4	Y	4
-8.5	Y	4
-8.5	Y	4

Once RISA is open, click OK to close the “Global Model Settings” dialogue box.

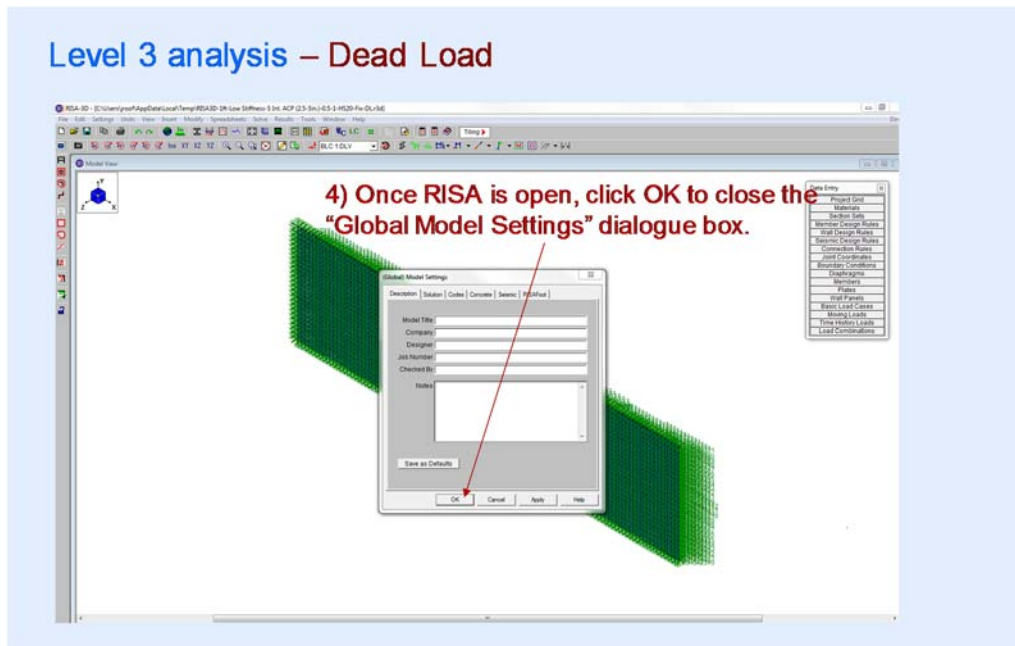

Click the “=” sign icon to analyze the model. Solution Choices window appears. Make sure Option “1: Total Loadcase Dead Load” is selected. And then click “Solve.”

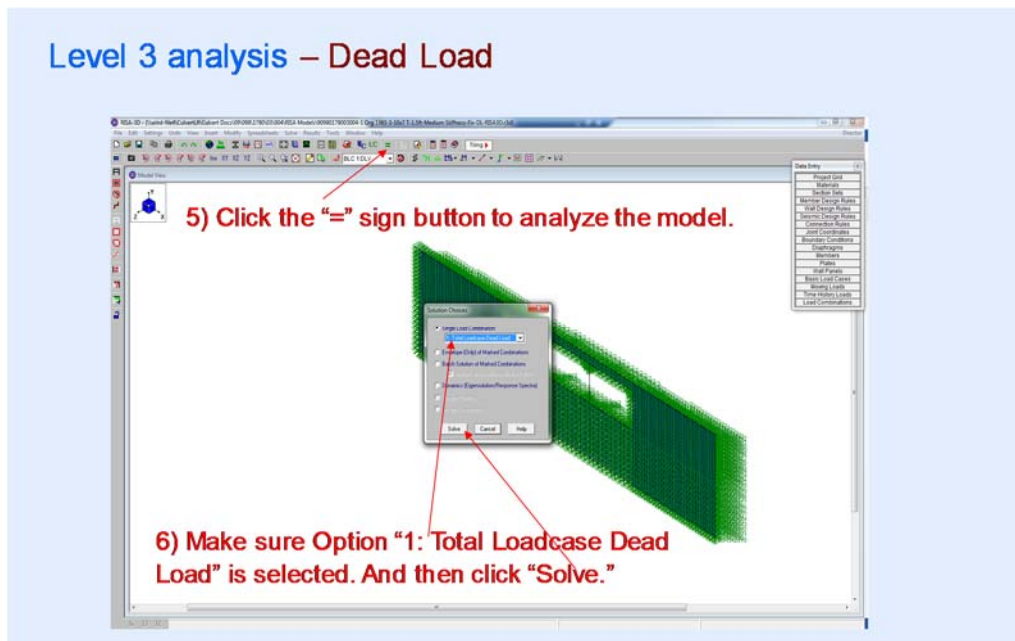

Once the analysis is completed, a dead load flat file must be created. Click Printer icon and Data Printing pop-up window will appear. Select “Use Report Printing Options” and click “OK.”

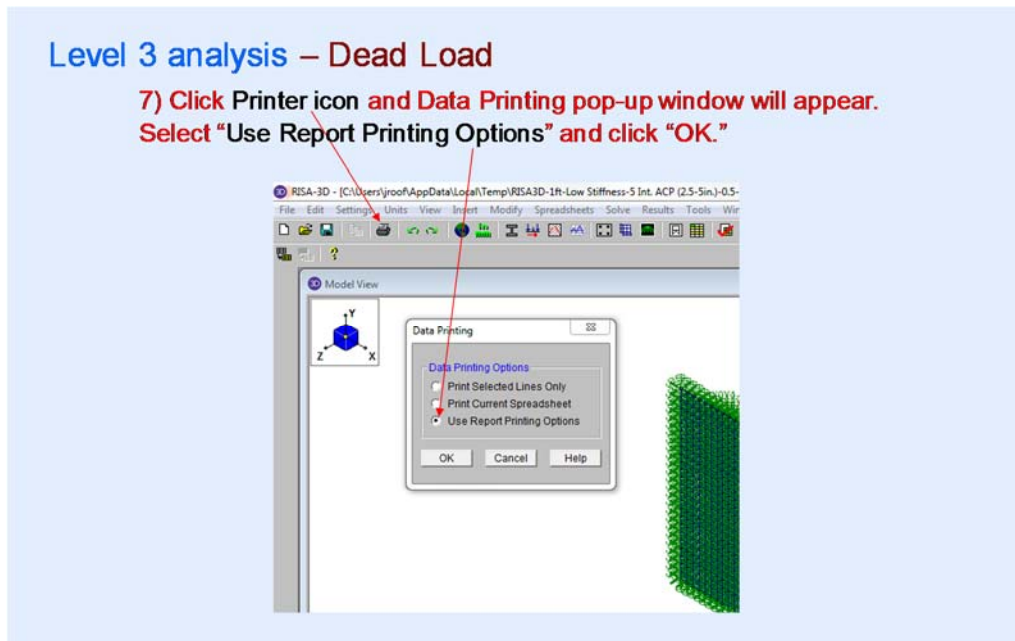

In the Report Printing dialogue box, select “Member Forces” and click “Add” to add member forces to the Section in Current Report.

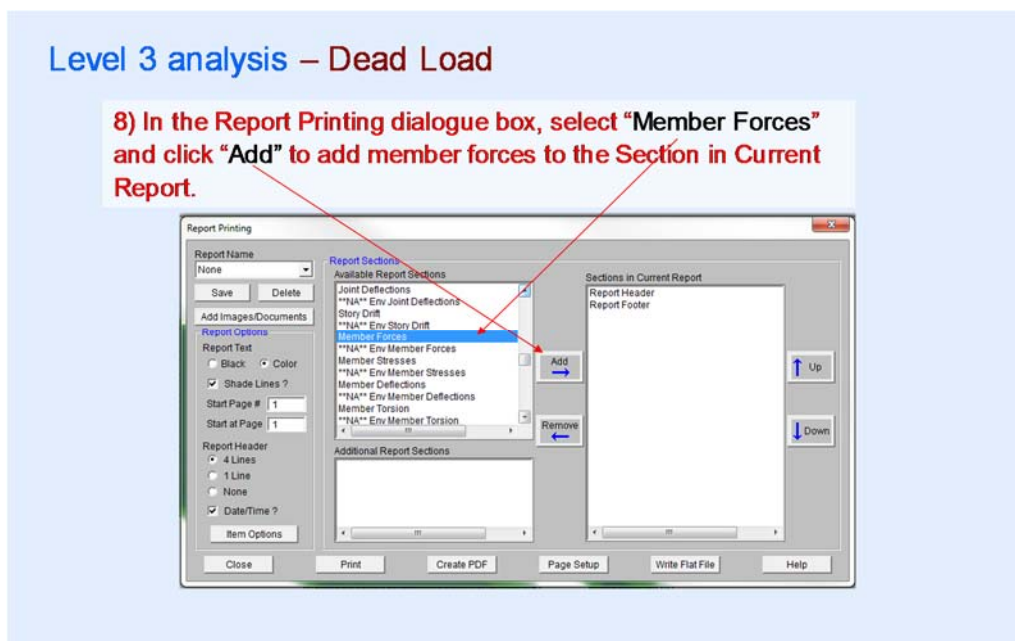

Click the “Write Flat File” button and click OK in the next dialogue box.

Level 3 analysis – Dead Load

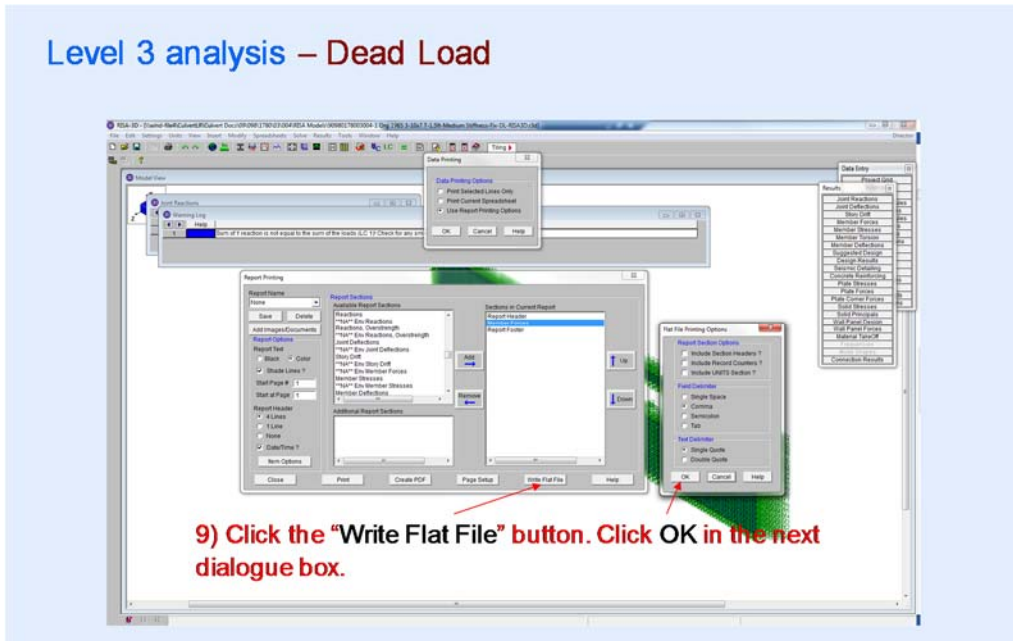

Save the flat file for dead load on your computer.

Level 3 analysis – Dead Load

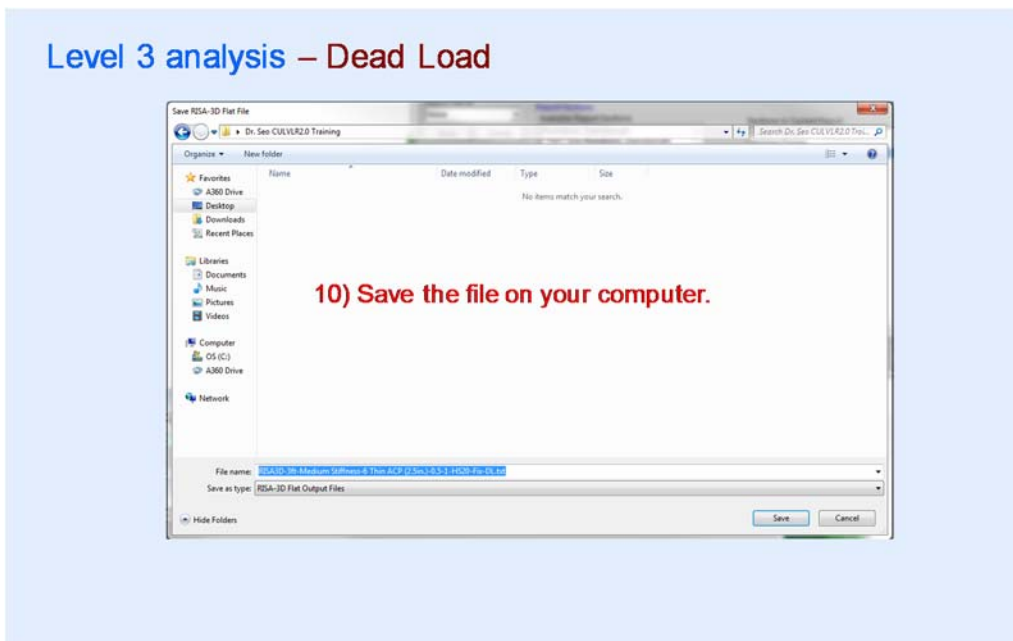

Live load analysis

Now it is time to solve for live load. Click “Create and Open LIVE LOAD MODEL in RISA-3D.”

Level 3 analysis – Live Load

a) Make sure your default run environments are correct:

- Interior Wall Top Fixity: “Fixed”
- Effect Moment of Inertia: “Recommended”
- Live Load Distribution: “LRFD 7th Ed.”
- Live Load Attenuation Method: “Section Depth Calibrated”
- Gamma Factors: “Recommended”

b) Click “Create and Open LIVE LOAD MODEL in RISA-3D.”

RISA will show a warning stating that the current results will be cleared. Close this warning by clicking “Yes.”

Level 3 analysis – Live Load

1) Clear results warning

Next, click “Moving Loads” on the Data Entry box. Right click the Pattern label and select the View/Edit Moving Load Patterns.

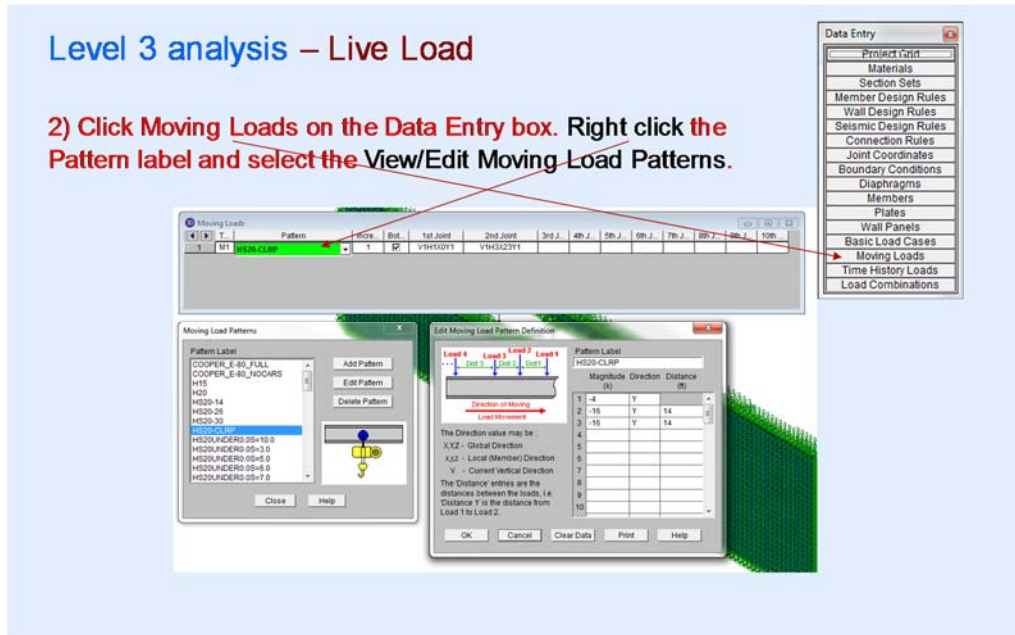

Select the Moving Load Pattern listed in the RISA-3D Analysis box if the desired load pattern exists and click the Edit Pattern button. Otherwise, from the Moving Load Patterns box click the Add Pattern button. In the Add Moving Load Pattern Definition dialogue box, copy/check the Pattern Label, Magnitude, Direction and Distance values from the Moving Load Pattern box from CulVLR2.0. When finished, click OK on the Add Moving Load Pattern Definition dialogue box.

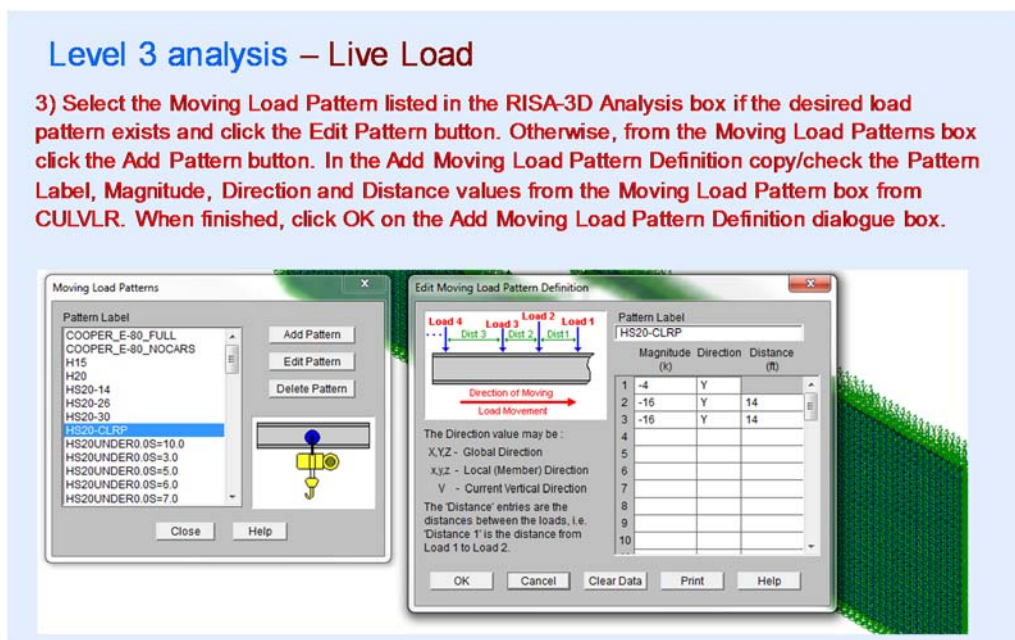

In the Moving Loads table, make sure the selected loading pattern is what you want and close the Moving Loads table.

Level 3 analysis – Live Load

4) Make sure the selected loading pattern is what you want.

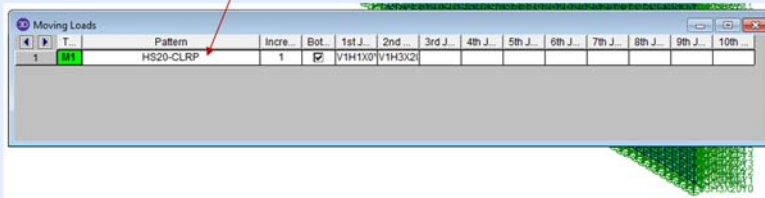

Click the “=” sign icon to analyze the model for live load and Make sure Option “1: Total Loadcase Live Load” is selected. And then click “Solve.”

Level 3 analysis – Live Load

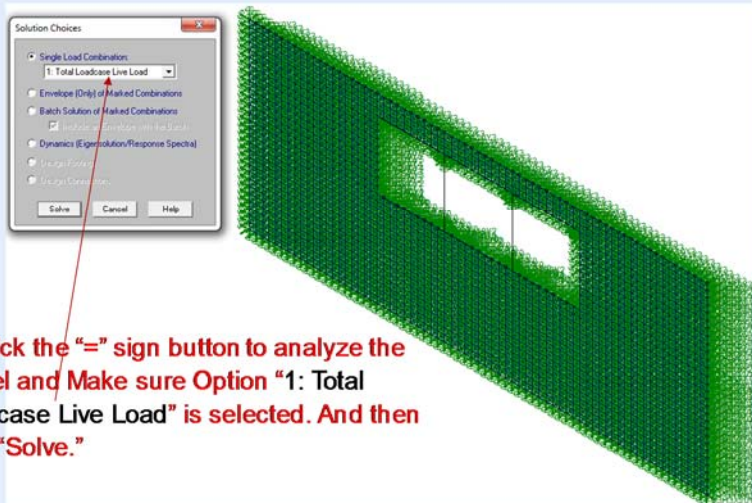

Click Printer icon and Data Printing pop-up window will appear. Select “Use Report Printing Options” and click “OK.”

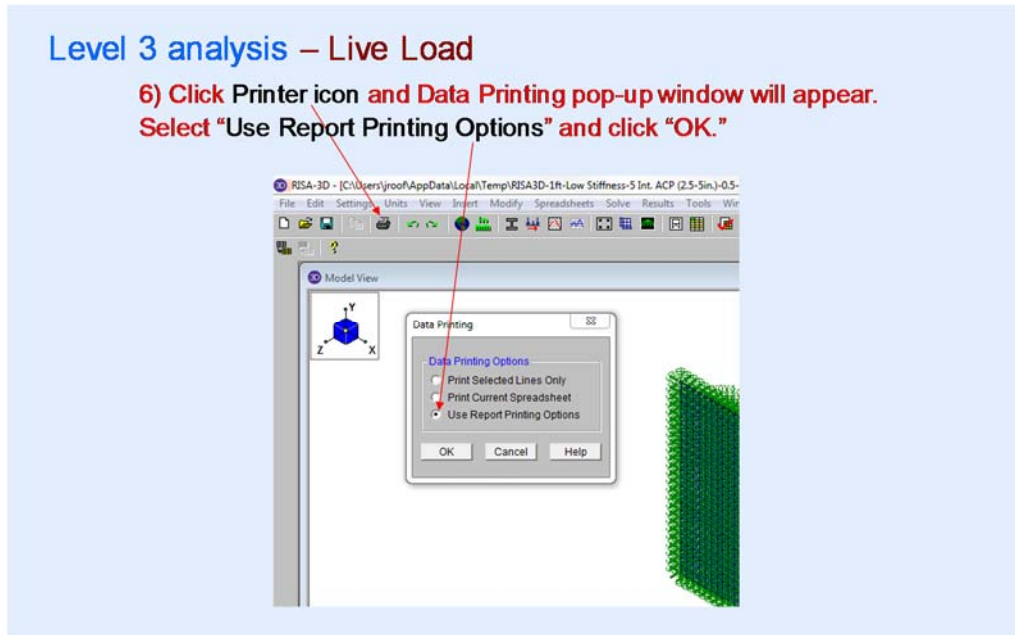

In the Report Printing dialogue box, select “Env Member Forces” and click “Add” to add member forces to the Section in Current Report.

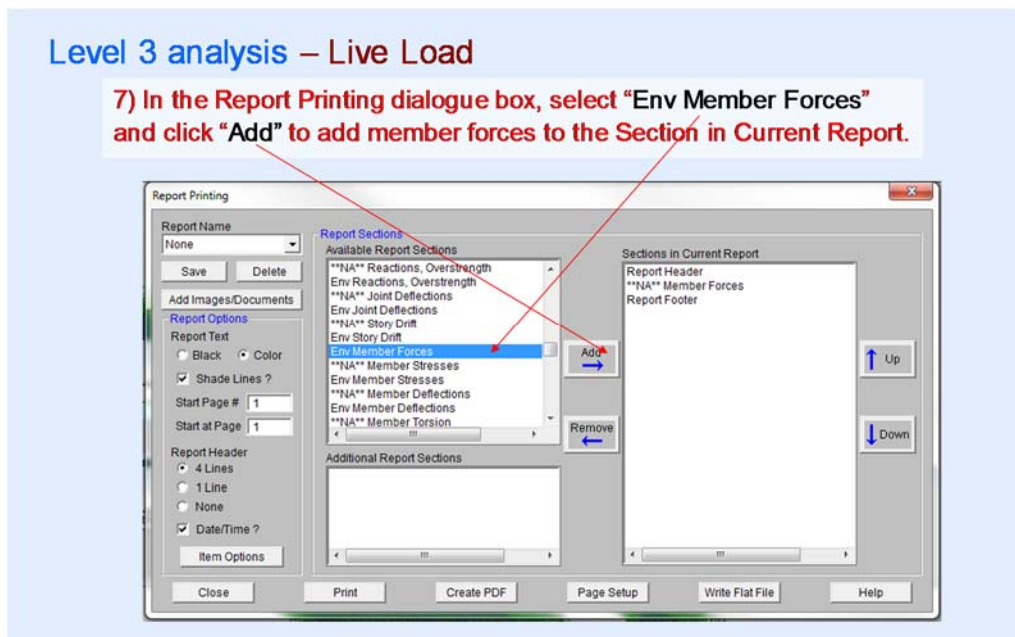

Click the “Write Flat File” button. Click OK in the next dialogue box.

Level 3 analysis – Live Load

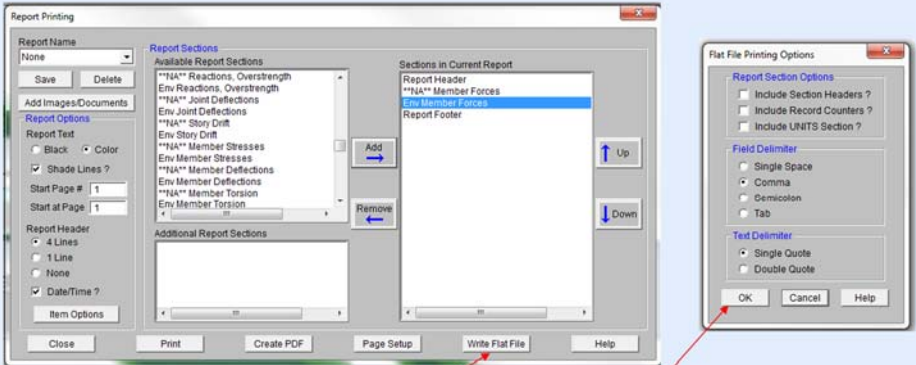

8) Click the “Write Flat File” button. Click OK in the next dialogue box.

Save the flat file for live load on your computer.

Level 3 analysis – Live Load

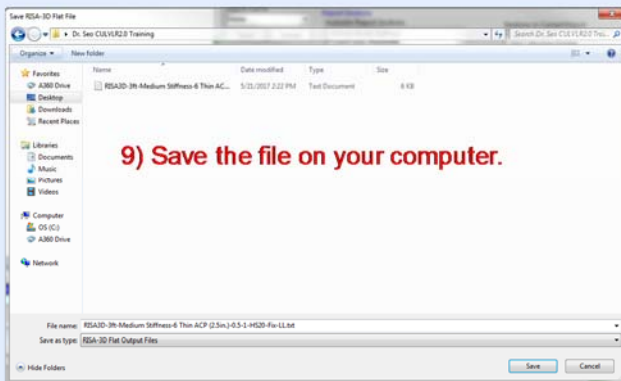

9) Save the file on your computer.

Import of Analysis Results into CulvLR2.0

Now that the RISA analysis has been completed, it is time to import the results in CulvLR2.0. Go back to CulvLR2.0, and click the Import RISA-3D Output Files in the RISA-3D Analysis dialogue box.

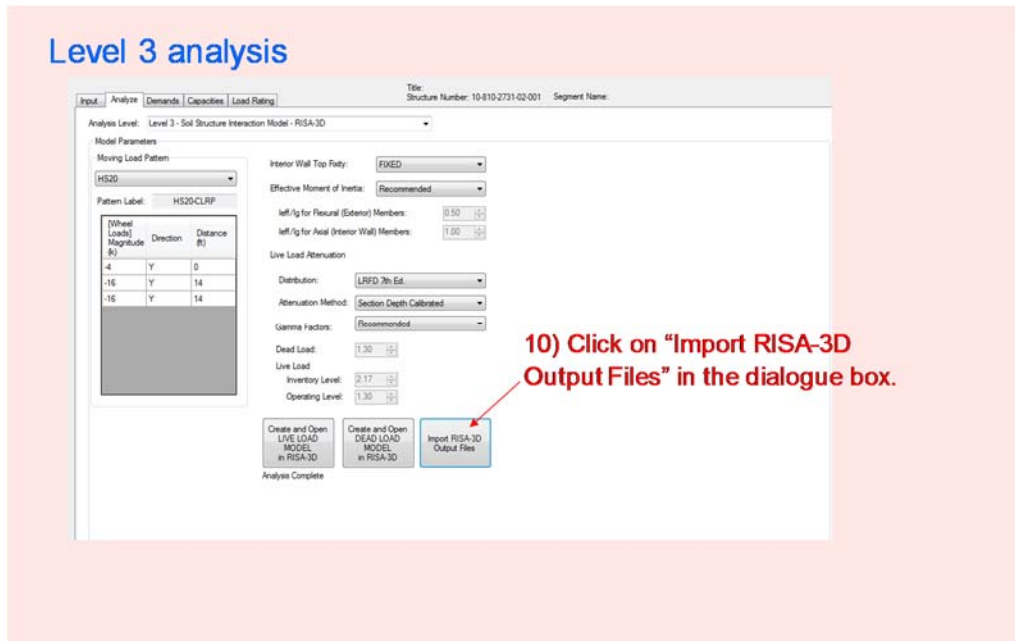

In the next dialogue box, select the Dead Load and Live Load files created in RISA and click open.

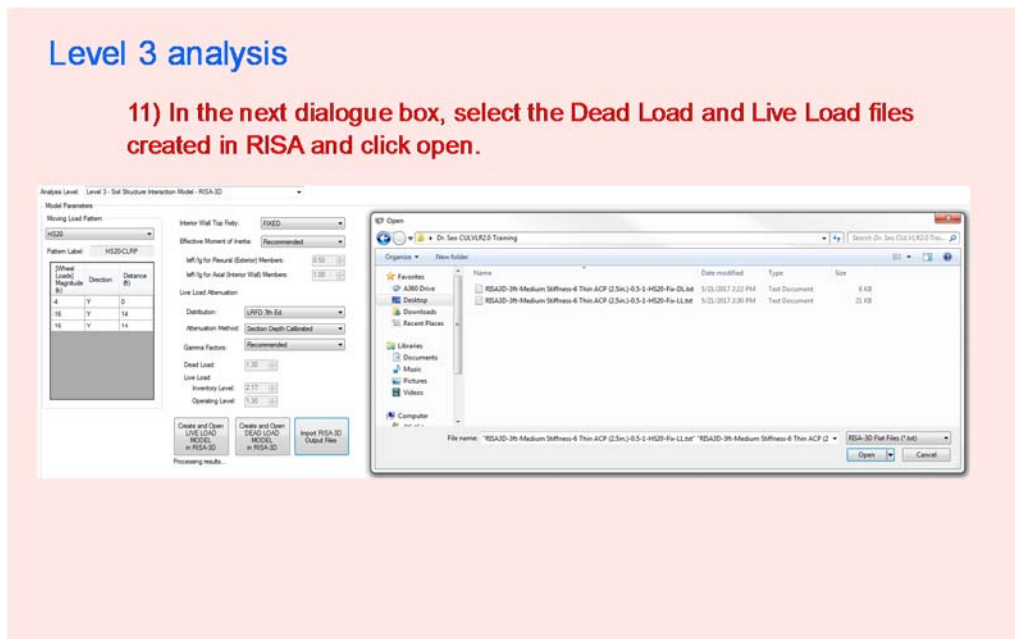

In this example, critical section is “Interior Wall Top” and therefore rerun is recommended. Click OK.

Level 3 analysis

12) In this example, critical section is “Interior Wall Top” and therefore rerun is recommended. Click OK.

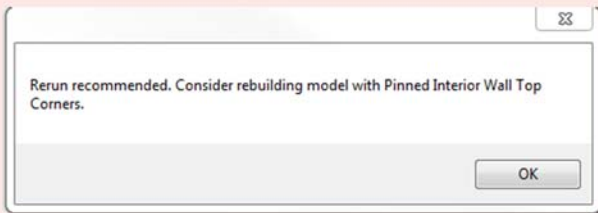

Critical Section Sketch in Load Rating tab confirms that interior top wall is a critical section. Operating rating factor (ORF) at the critical section with fixed condition at interior top wall is 2.16.

Level 3 analysis – Fixed condition

Click “Load Rating” tab to view the results with fixed condition at interior top wall.

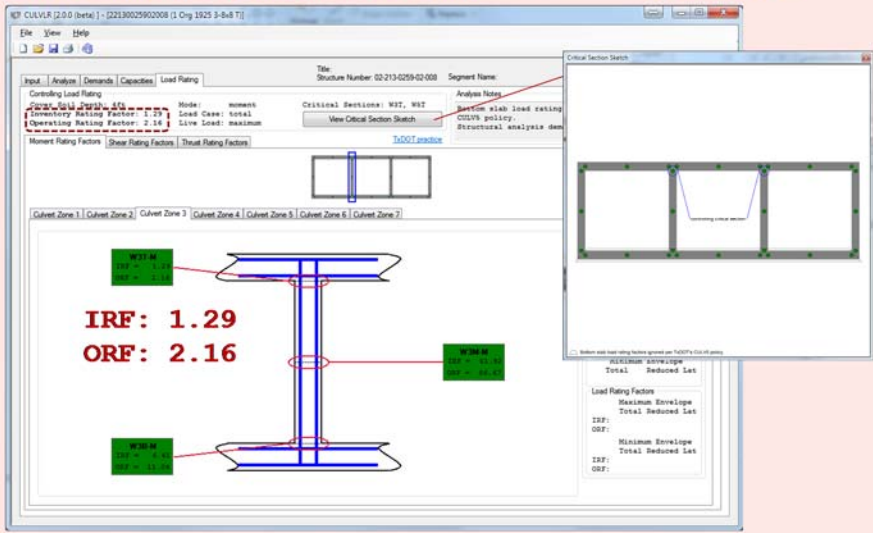

To rerun as pinned condition, select the Interior Wall Top Fixity as “PINNED” in Analyze tab and repeat the RISA analysis for dead and live loads.

Level 3 analysis – Pinned condition

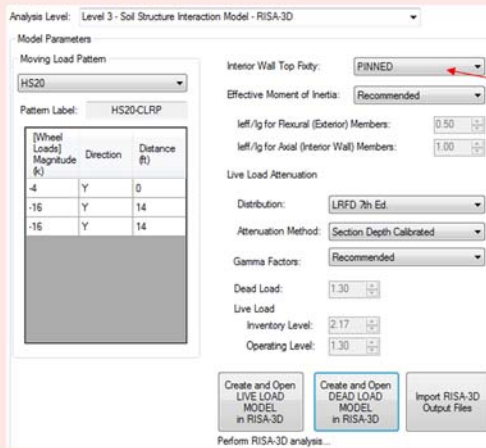

To rerun as pinned condition, select “PINNED” and repeat the same RISA analysis.

Upon completion of RISA analysis, import the RISA output files with pinned condition.

Level 3 analysis – Pinned condition

Upon completion of RISA analysis, import the RISA output files with pinned condition.

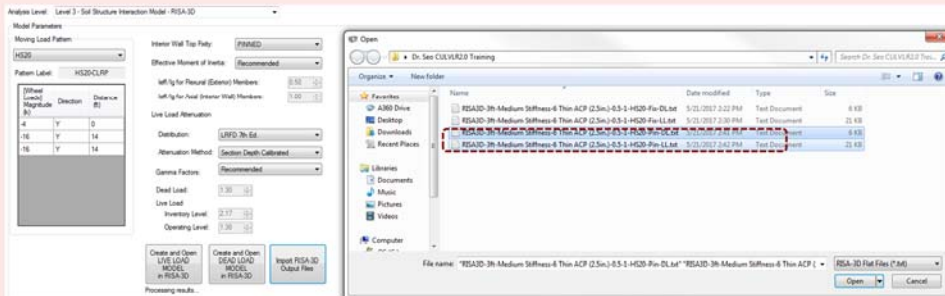

When the flat files with pinned condition are imported, a message box asking “Would you like to view the Load Rating Results?” appears. Click Yes, it then takes you to the Load Rating tab. Critical section has moved to top slab interior corner. Operating rating factor (ORF) at the critical section with pinned condition at interior top wall has increased to 9.35.

Level 3 analysis – Pinned condition
 Click “Load Rating” tab to view the results with pinned condition at interior top wall.

The screenshot displays the CULVR software interface. On the left, a message box titled "Level 3 - Analysis Complete" asks "Would you like to view the Load Rating Results?" with "Yes" and "No" buttons. The main window shows the "Load Rating" tab with the following data:

- Operating Rating Factor: 9.35
- Moment Rating Factor: [blank]
- IRF: 5.6
- ORF: 9.35

The main window also features a "Critical Section Sketch" window showing a cross-section of the culvert with a highlighted critical section at the interior top wall. A table on the right side of the main window lists various capacity and load rating factors:

Capacity	Positive	Negative
Dead Load Demand	Total	Subtotal L&S
Live Load Demand	Maximum Envelope	Total
Minimum Envelope	Total	Subtotal L&S
Load Rating Factors	Maximum Envelope	Total
ORF	Minimum Envelope	Total
ORF	Minimum Envelope	Total
ORF	Minimum Envelope	Total

Level 1 Analysis for Segment 2

Open *.clrp file for Segment 2 and perform Level 1 analysis. Results are as follows:

Level 1 analysis: 2 Wid 1953 3-8x6 T

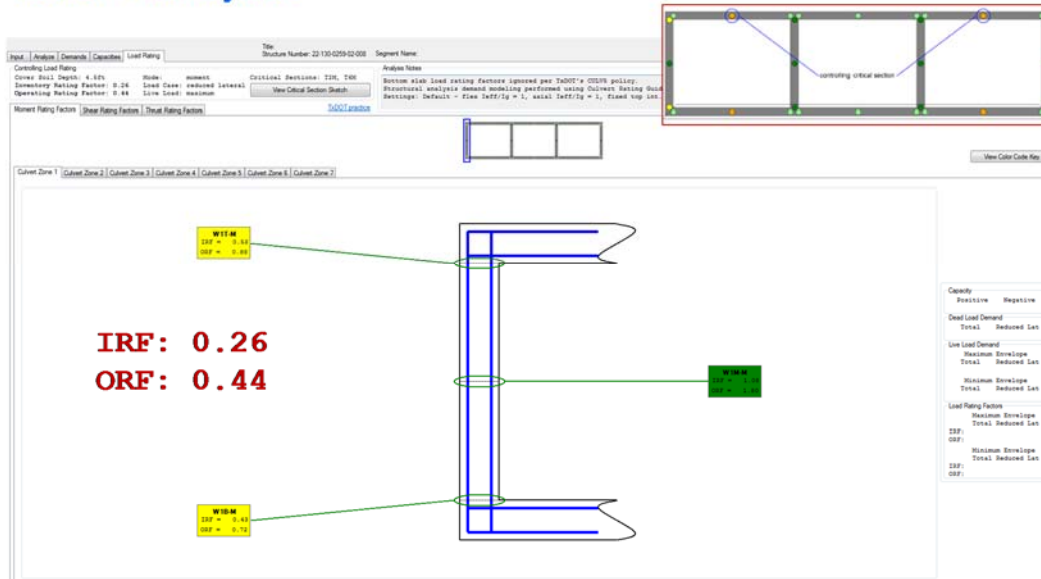

Results from Level 3 analysis for Segment Zone 2 are shown below. Note that critical section from the analysis with the default parameters is not the interior top wall. Therefore, there is no need to rerun as pinned.

Level 3 analysis (Fixed): 2 Wid 1953 3-8x6 T

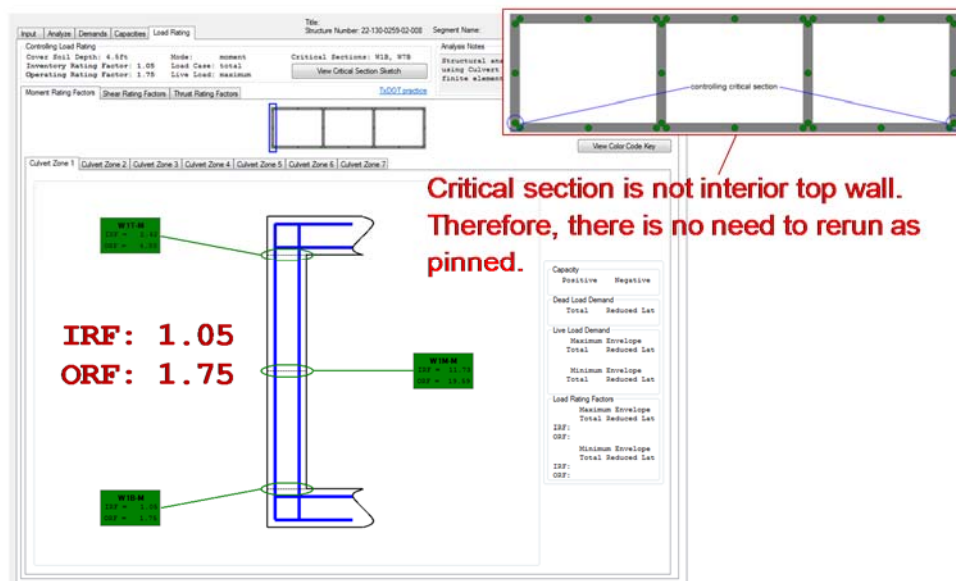

Load Rating Summary

Summary of load rating results for the structure are shown in the table below. As shown in the table, Segment 2 controls load rating of this culvert.

Analysis level	Segment 1		Segment 2	
	IRF	ORF	IRF	ORF
Level 1	1.74	2.91	0.26	0.44
Level 3	5.6	9.35	1.05	1.75

The following additional examples on Load Rating Calculations can be found in Module 6 of the training materials:

- EXAMPLE 1: 01-075-0279-04-013 (Example 6.1)
- EXAMPLE 2: 01-081-2731-02-001 (Example 6.2)

APPENDIX F

EXAMPLE

"REPORTING"

Example 7.3

Example 7.3 is about Task 7: Review and Reporting (Module 7 in training materials). Objective of Task 7 is to review load rating results and create reports of Level 1 and 3 analyses results.

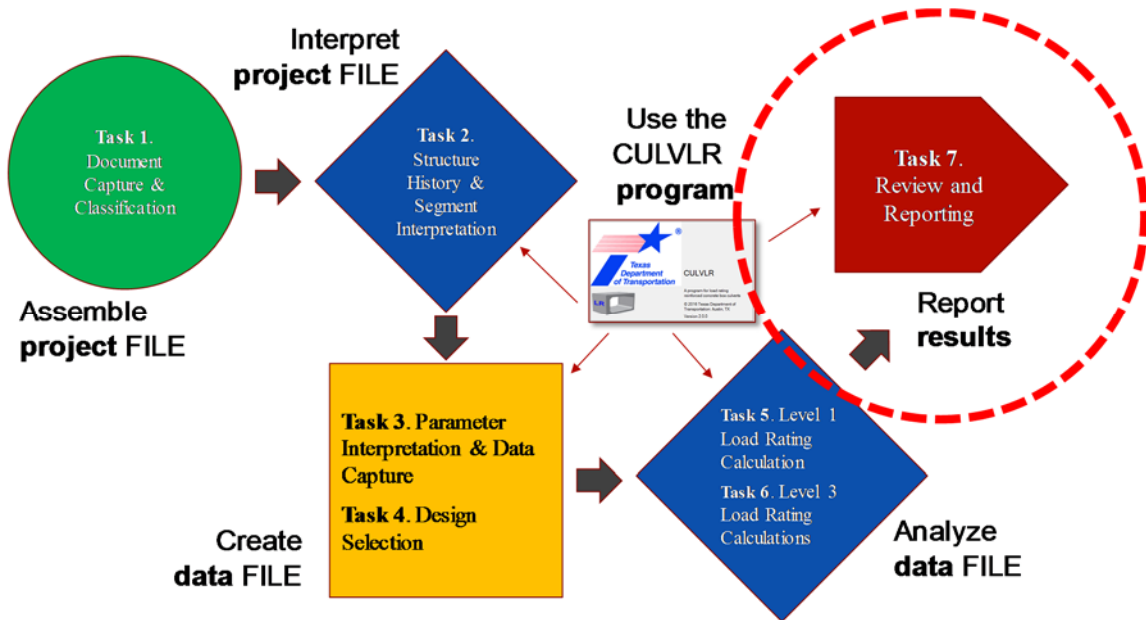

Level 1 Results Review

This example presents how to review load rating results and create summary reports of Level 1 and Level 3 analysis results for Segment 2 of the Example culvert (Str. No. 02-213-0259-02-008).

Upon completion of Level 1 analysis, CulvLR2.0 redirects the screen to Load Rating tab. On the first screen, a high-level summary is provided. The lowest rating from all sections and all load effects is shown in Controlling Load Rating area. IRF and ORF are 0.26 and 0.44, respectively, and the controlling mode of failure is moment with maximum live load and reduced lateral load. Critical sections are T2M and T6M, and the locations of these sections can be identified by clicking “View Critical Section Sketch” button. These locations correspond to Culvert Zones 2 and 6. Clicking Culvert Zone 2 tab shows rating factors at critical sections in Zone 2, and it is confirmed that the IRF and ORF are indeed 0.26 and 0.44 at T2M.

* Because rating factors are computed for moment, shear, and thrust at each potential critical section, there are three sub-tabs – Moment Rating Factors, Shear Rating Factors, and Thrust Rating Factors – in Load Rating tab. Rating factors for each load effect can be viewed by clicking the corresponding sub-tab.

Level 1 results

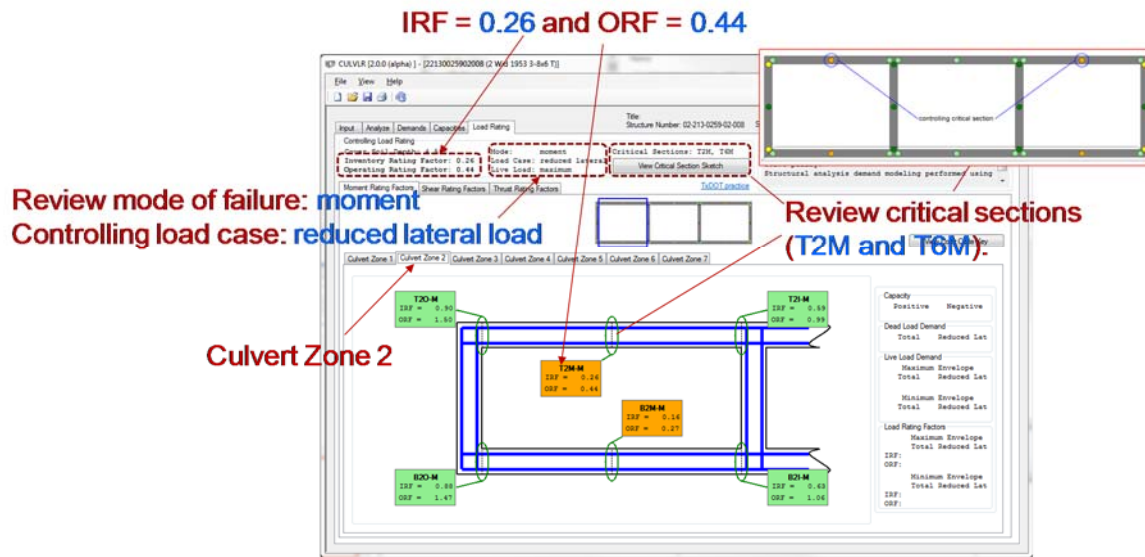

Capacities at each potential critical section can be viewed by clicking Capacities tab. Capacities at T2M in Zone 2 per design standard MC8-2-1949 are as follows:

Capacities at critical section:

- $M+ = 4.42$ k-ft/ft
- $M- = -2.42$ k-ft/ft
- $V+ = 9.22$ k/ft
- $V- = -11.73$ k/ft
- $P = -134.66$ k/ft

Level 1 results

Capacities at critical section:

$M+ = 4.42$ k-ft/ft
 $M- = -2.42$ k-ft/ft
 $V+ = 9.22$ k/ft
 $V- = -11.73$ k/ft
 $P = -134.66$ k/ft

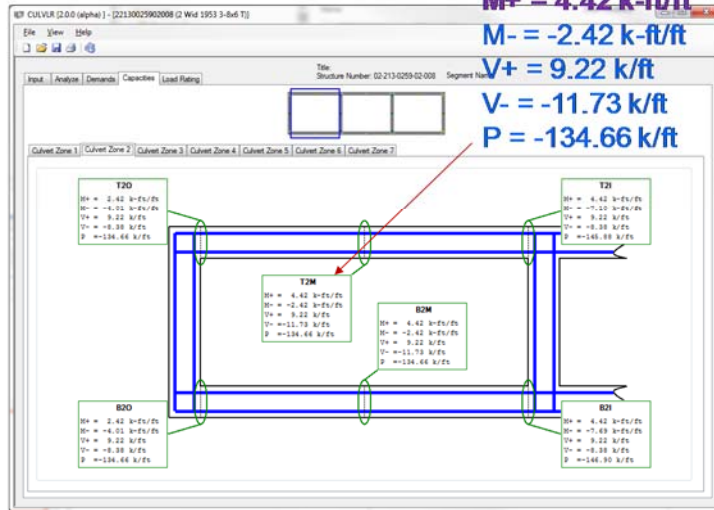

Demands tab has three sub-tabs: Moment Demands, Shear Demands, and Thrust Demands. To review the moment demands at T2M obtained using CULV5 for total and reduced lateral loads, click Moment Demands tab and then Culvert Zone 2 tab:

Moment demands at critical section:

- Total load Reduced load
- Dead = 2.50 k-ft/ft 2.62 k-ft/ft
- Live Max = 1.74 k-ft/ft 1.80 k-ft/ft
- Live Min = -0.38 k-ft/ft -0.33 k-ft/ft

Level 1 results Moment demands at critical section:
Total load **Reduced load**
Dead = 2.50 k-ft/ft **2.62 k-ft/ft**
Live Max = 1.74 k-ft/ft **1.80 k-ft/ft**
Live Min = -0.38 k-ft/ft **-0.33 k-ft/ft**

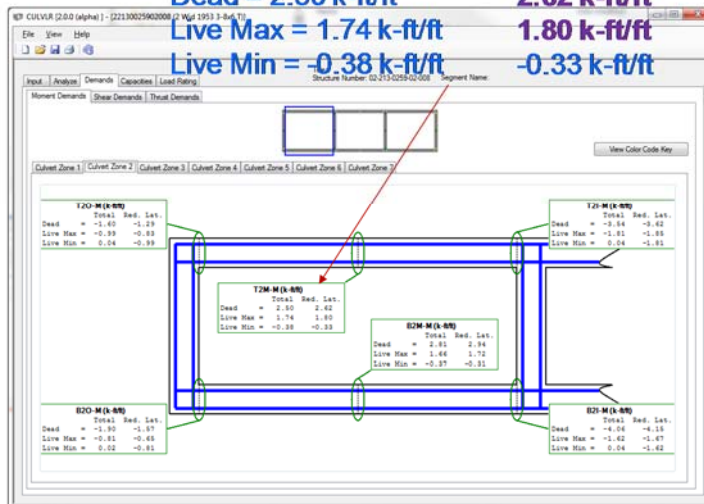

Report Creation (Level 1)

To create reports of Level 1 analysis results, click “File > Create Reports.” Three printing options are available in Reporting Options window:

- Create Summary Report
- Create Summary Report with Input
- Create Comprehensive Report

Level 1 results – Report Printing

2) In the next dialogue box, click “Create Summary Report” button.

1) Click “File > Create Reports”

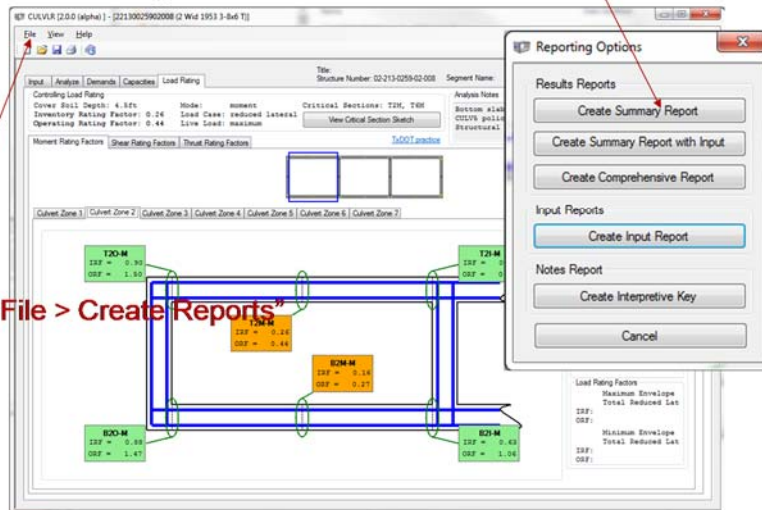

Click "Create Summary Report" to generate 1-page summary report in PDF as follows:



Texas Department of Transportation

SUMMARY REPORT
CULVERT LOAD RATING

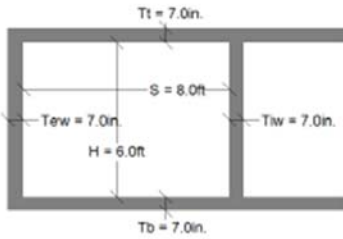
General Information		Culvert Segment Sketch		
Structure Number: 22-130-0259-02-008				
Culvert Segment: 2 Wid 1953 3-8x6 T				
Facility Carried:				
Feature Crossed: Woods Branch				
Design Sheet: MC8-2-1949				
Construction Year: 1953				
Steel Grade: Pre-1954 (Fy=33000 psi)				
Concrete Class: Class A (F'c=3000 psi)				
Number of Spans: 3				
Clear Span: 8.0ft				
Clear Height: 6.0ft				
PMIS Pavement: 4 Thick ACP (>5in.)				
Soil Properties: TxDOT Practice				Total Equivalent Fluid Weight: 40pcf
Soil Unit Weight: 120pcf				Reduced Equivalent Fluid Weight: 20pcf
Rating Vehicle: HS20				

Controlling Load Rating				
Cover Soil Depth: 4.5ft	Mode: moment	Capacity: 4.423k-ft		
Inventory Rating Factors: 0.26	Load Case: reduced lateral	Dead Load: 2.615k-ft		
Operating Rating Factors: 0.44	Live Load: maximum	Live Load: 1.802k-ft		
Reported demand loads are unfactored. Inventory rating, operating rating and load rating factors incorporate an impact factor of 0.				

Critical Section Sketch

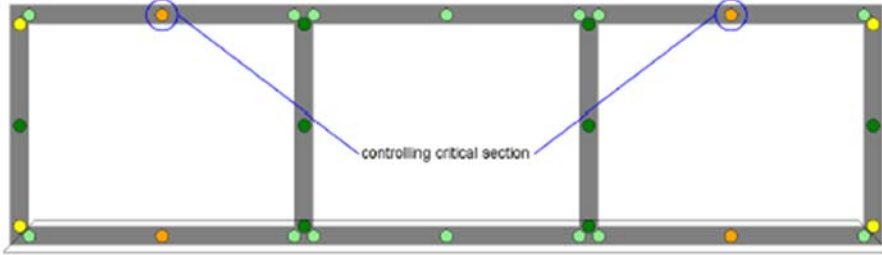

△ Bottom slab load rating factors ignored per TxDOT's CULV5 policy.
Refer to CULVLR program for key to interpreting critical section color codes.

Analysis Summary

- Load rating calculations performed according to the TxDOT *Culvert Rating Guide, 2nd Ed.* (2017).
- Demand modeling performed using Level 1: CULV5 2.2.2 as implemented in CULVLR 2.0.0.
- Settings: Default - flex $l_{eff}/l_g = 1$, axial $l_{eff}/l_g = 1$, fixed top int. wall, SSHB distribution

Comments	Personnel
Bottom slab load rating factors ignored per TxDOT policy. 1.2 Mi West of FM 203	Prepared: TML 05/21/2017 Checked: 05/21/2017

Structure Number: 22-130-0259-02-008
Issue Date: May 21, 2017
CULVLR [2.0.0]
Page 1 of 1

Level 3 Results Review

Upon completion of Level 3 analysis, CulvLR2.0 redirects the screen to Load Rating tab. On the first screen, a high-level summary is provided. The lowest rating from all sections and all load effects is shown in Controlling Load Rating area. IRF and ORF are 1.05 and 1.75, respectively, and the controlling mode of failure is moment with maximum live load and total lateral load. Critical sections are W1B and W7B, and the locations of these sections can be identified by clicking “View Critical Section Sketch” button. These locations correspond to Culvert Zones 1 and 7. It is confirmed that the IRF and ORF are indeed 1.05 and 1.75 at W1B in Zone 1.

Level 3 results

IRF = 1.05 and ORF = 1.75

Review mode of failure = moment

Review critical sections (W1B and W7B)

Critical section

Capacity	Max/Min	Positive	Negative
Dead Load Demand	Total	Reduced	Lat
Live Load Demand	Total	Reduced	Lat
Minimum Envelope	Total	Reduced	Lat
Load Rating Factors	Maximum Envelope	Total	Reduced Lat
ISF:			
ORF:			
Minimum Envelope	Total	Reduced	Lat
ISF:			
ORF:			

Capacities at each potential critical section can be viewed by clicking Capacities tab. Capacities at W1B in Zone 1 per design standard MC8-2-1949 are as follows:

Capacities at critical section:

- $M+ = 2.42$ k-ft/ft
- $M- = -4.01$ k-ft/ft
- $V+ = 11.73$ k/ft
- $V- = -8.38$ k/ft
- $P = -134.66$ k/ft

Level 3 results

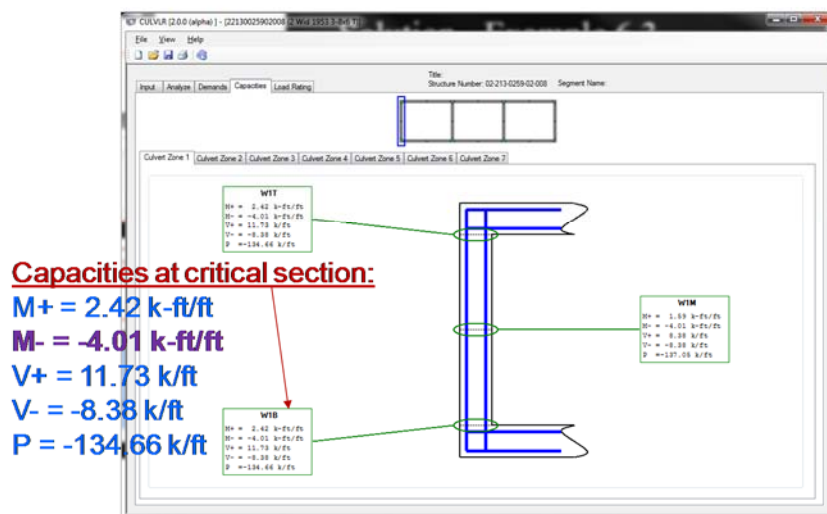

To review the moment demands at W1B obtained using RISA for total lateral load, click Moment Demands tab and then Culvert Zone 1 tab:

Moment demands at critical section:

- Dead = -2.63 k-ft/ft
- Live Max = -2.34 k-ft/ft
- Live Min = 0.08 k-ft/ft

Level 3 results

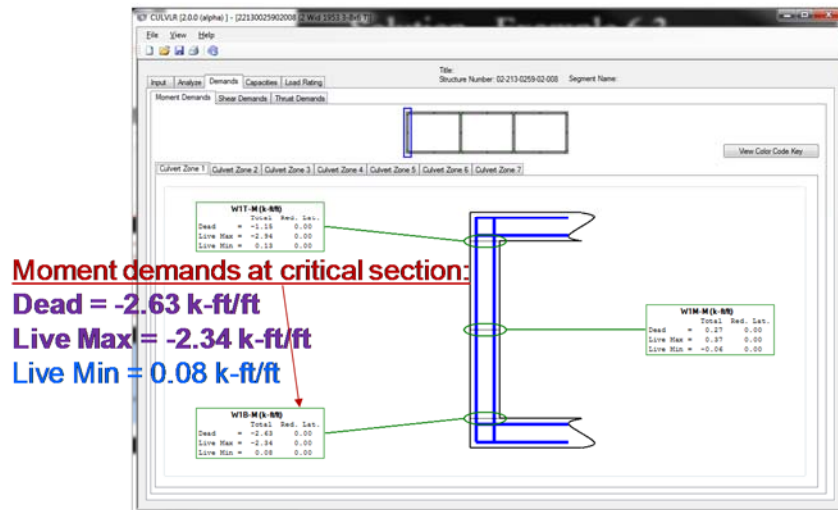

To create reports of Level 3 analysis results, click “File > Create Reports” and then “Create Summary Report” button.

**Level 3 results
– Report Printing**

2) In the next dialogue box, click “Create Summary Report” button.

1) Click “File > Create Reports”

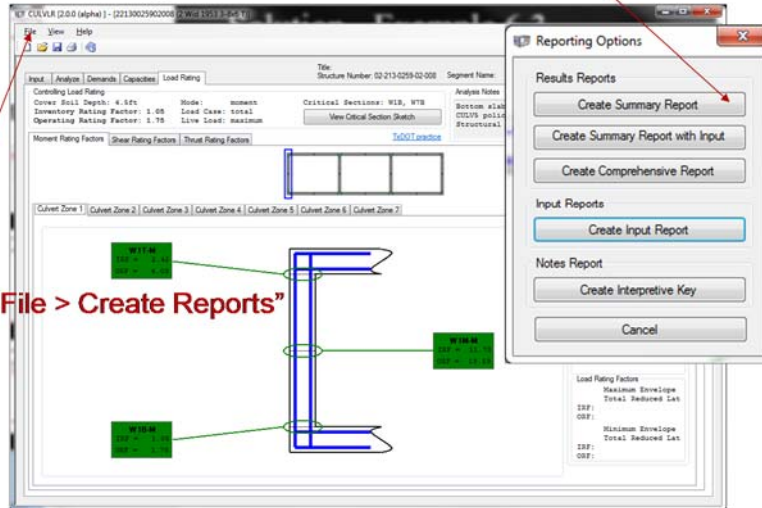

Report Creation (Level 3)

One-page summary report of Level 3 analysis results is created in PDF as follows:



Texas Department of Transportation

SUMMARY REPORT
CULVERT LOAD RATING

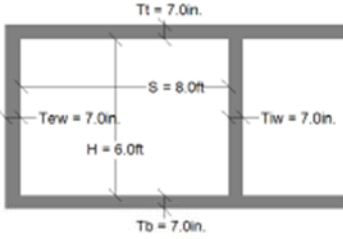
General Information		Culvert Segment Sketch	
Structure Number:	02-213-0259-02-008		
Culvert Segment:	2 Wid 1953 3-8x6 T		
Facility Carried:	US 67		
Feature Crossed:	Woods Branch		
Design Sheet:	MC8-2-1949		
Construction Year:	1953		
Steel Grade:	Pre-1954 (Fy=33000 psi)		
Concrete Class:	Class A (F'c=3000 psi)		
Number of Spans:	3		
Clear Span:	8.0ft		
Clear Height:	6.0ft		
PMIS Pavement:	4 Thick ACP (>5in.)		
Soil Properties:	Medium Stiffness		
Soil Unit Weight:	120pcf	Soil Poisson's Ratio:	0.3
Rating Vehicle:	HS20		

Controlling Load Rating			
Cover Soil Depth:	4.5ft	Mode:	moment
Inventory Rating Factors:	1.05	Load Case:	total
Operating Rating Factors:	1.75	Live Load:	maximum
Capacity:		-4.007k-ft	
Dead Load:		-2.633k-ft	
Live Load:		-2.338k-ft	
Reported demand loads are unfactored. Inventory rating, operating rating and load rating factors incorporate an impact factor of 0.144375.			

Critical Section Sketch

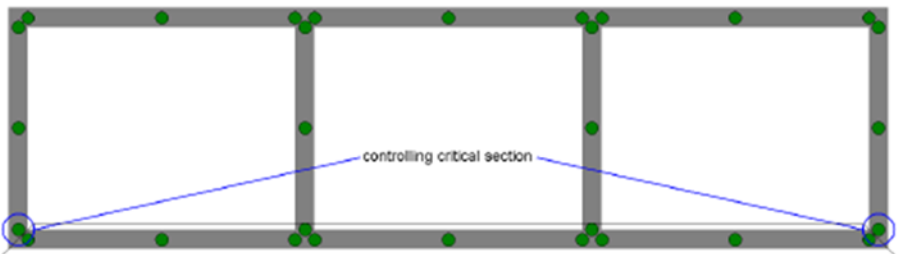

△ Bottom slab load rating factors ignored per TxDOT's CULV5 policy.
 Refer to CULVLR program for key to interpreting critical section color codes.

Analysis Summary

- Load rating calculations performed according to the TxDOT *Culvert Rating Guide, 2nd Ed.* (2017).
- Demand modeling performed using Level 3: RISA-3D 14.0 as implemented in CULVLR 2.0.0.
- Settings: flex $l_{eff}/l_g = 1$, axial $l_{eff}/l_g = 1$, fixed top int. wall, LRF 7th distribution

Comments	Personnel
Bottom slab load rating factors ignored per TxDOT policy.	Prepared: 05/20/2017 Checked: 05/20/2017

Structure Number: 02-213-0259-02-008
Issue Date: May 21, 2017
CULVLR [2.0.0]
Page 1 of 1

